



USER MANUAL

24513

Maritime Wind Sensor



Content

1	Warranty	3
2	Description	3
2.1	General	3
2.2	Function	3
2.3	Dimensioned drawing	4
2.4	Message string WIMWV	5
3	Setting into operation	6
3.1	Unpacking	6
3.2	Choice of the installation site	6
3.3	Mounting	6
3.4	Electrical connection	7
3.5	Cable entries	8
3.6	Start-up	8
3.7	Functional test	8
4	Service and maintenance	8
4.1	Replacement of spare parts	8
4.2	Repair procedures	9
4.3	Ordering spare parts	9
5.0	Set device out of operation	9
5.1	Storage	9
5.2	Dispatch	9
5.3	Remarks	9
6	Disposal	10
7	Overview spare parts	10
8	Technical data	11

1 Warranty

Please note the loss of warranty and non-liability by unauthorized manipulation of the system. You need a written permission of the LAMBRECHT meteo GmbH for changes of system components. These activities must be operated by a qualified technician.

The warranty does not cover:

1. Mechanical damages caused by external impacts (e.g. icefall, rockfall, vandalism).
2. Impacts or damages caused by over-voltages or electromagnetic fields which are beyond the standards and specifications in the technical data.
3. Damages caused by improper handling, e.g. by wrong tools, incorrect installation, incorrect electrical installation (e.g. false polarity) etc.
4. Damages which are caused by using the device beyond the specified operation conditions.

2 Description

2.1 General

The wind sensor 24513-NMEA is specifically designed for the operating on ships, oil rigs, and other applications on sea. The housing and the measuring elements are made of a seawater resistant aluminium alloys. Housing, cup-rotor, and wind vane are anodized.

Due to the special construction with a watertight connector and splash proof traps for the bearings and due to the shock and vibration proof construction, the sensor is fully qualified for a long service life on ships. An electronically controlled sensor heating device (option) allows operating the sensor over the wide range from -35 up to 70 °C.

2.2 Function

The wind sensor 24513-NMEA has two different measuring elements to measure wind speed and wind direction. The three-armed cup rotor will rotate from the wind. The number of revolutions of the cup rotor is proportional to the wind speed. The wind direction is measured with a wedge wind vane with two fins. The wind vane axis and the rotor cup axis are coaxial, running independently of each other on ball bearings.

2.3 Dimensioned drawing

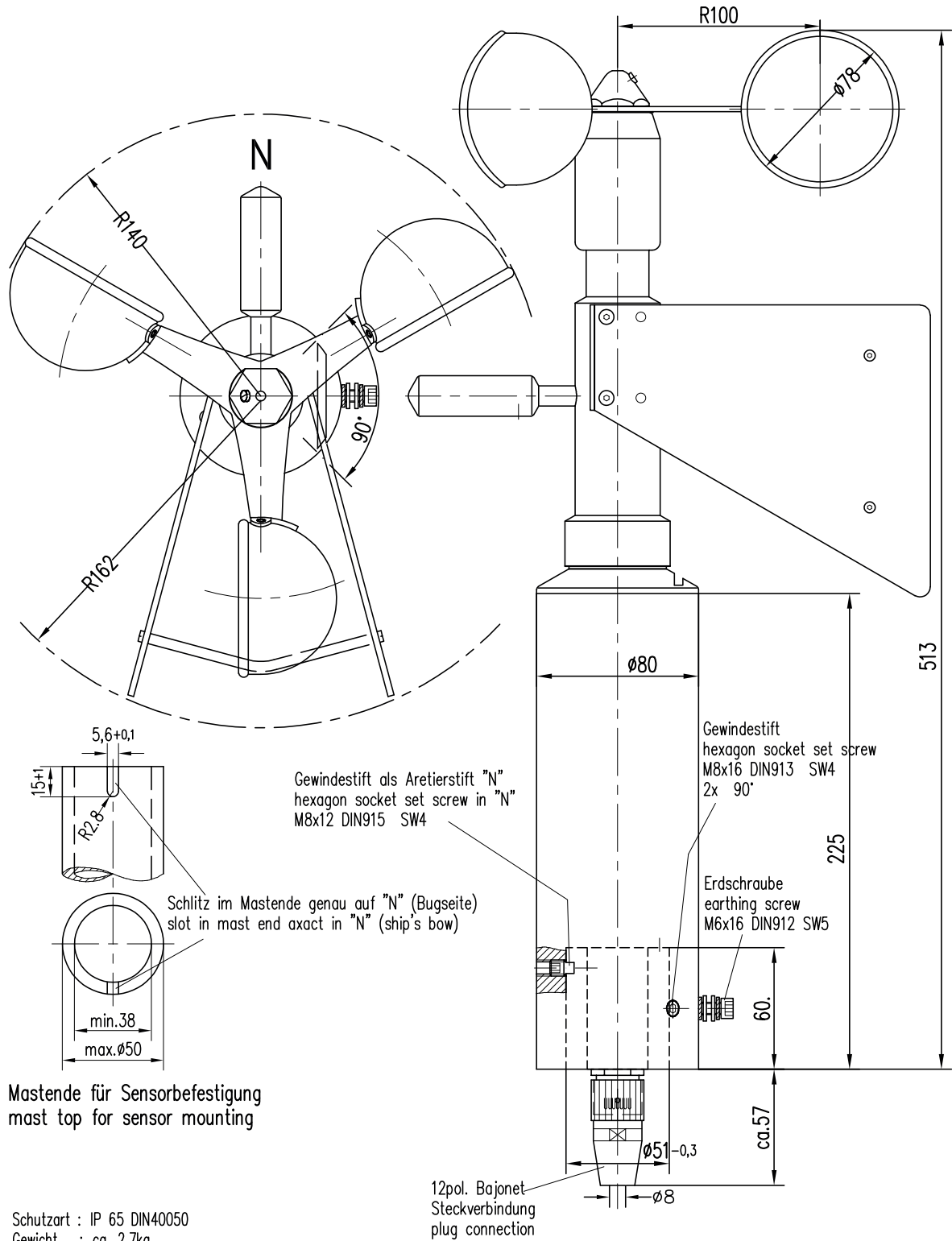

Mastende für Sensorbefestigung
mast top for sensor mounting

Schutzart : IP 65 DIN40050
Gewicht : ca. 2,7kg

protection
Type: IP 65 DIN40050
weighth : approx. 2.7kgs

Maßstab/scale : 1:2,5

2.4 Message string WIMWV

WIND DIRECTION AND WIND SPEED

Example of data sequence with comma separated

fields: \$WIMWV,357.0,R,5.2,M,A*CS<CR><LF>

field delimiter: , (comma)

header: \$WIMWV

wind direction: 0.0 to 360.0

R: relative wind direction

wind speed: 0.4 to 60.0

M: metric units m/s

status A (valid) / V (not valid)

stop delimiters: <CR> <LF>

error code: WD 999.9

error code: WS 999.9

NORMS

Emission

EN 60945:2002

CISPR 16-1:1999 Part 1

Immunity

EN 60945:2002

includes:

EN 61000-4-6:1996

Injected RF currents

EN 61000-4-3:2002

Radiated RF fields

EN 61000-4-4:1995

Burst

EN 61000-4-2:1995

ESD

EN 61000-4-5:1995

Surge

EN 61000-4-11:1994

Voltage variations

IMPORTANT! PLEASE NOTE:

FIELD LENGTH

The development of a NMEA decoder should not be proceeded from firm field lengths. The NMEA definition proceeds from a variable field length. The comma character (“,”) serves as field disconnecting switch. Numeric values in a field can be presented differently. In case a field is not sent, it has a length of 0 characters (,,) [comma-comma].

CHECK SUM

The check sum “CS” is covered to two ASCII characters hexadecimal value. “CS” calculated by XOR operation of each character in the sentence between “\$” and “*”, but excluding “\$” and “*”.

ERROR CODE

In case, that the sensor cannot generate a measuring value because e.g. a sensor element is defect or implausible (raw) values are collected the sensor outputs in the corresponding data protocol the above mentioned error code (e.g. 999.9) and sets the status from “A” (valid) to “V” (not valid).

Example: \$WIMWV,999.9,R,999.9,M,V*37<CR><LF>

PARTICULAR CHARACTERISTICS WIND DIRECTION VALUE

Theoretically the value for the wind direction can take any value between 0.0° and 360.0°. It should be noted, that in a full circle the values “0.0” and “360.0” are describing the same direction. According to the international valid recommendations of the WMO (World Meteorological Organization) in the “Guide to Meteorological Instruments and Methods of Observation” (WMO-No.8) the wind direction value 0.0° just has to be output at calm. The sensor follows the recommendation of the WMO and outputs at wind from the north the value “360.0” respectively “0.0” at calm (lull).

3 Setting into operation

3.1 Unpacking



When removing the sensor from the original box take care not to damage the cup rotor and the wind vane. The measuring elements must not be used as a handle.

3.2 Choice of the installation site

For representative wind measuring the sensor should not be installed under the lee of large obstacles. The distance between obstacle and sensor should be at least ten times the height of the obstacle. Furthermore the sensor should be at least 5 meter higher than the height of the obstacle.

For operation on ships you should select a mounting place with little interferences of obstacles such as masts, antennas, and chimneys. In most cases the users mount the sensor on a crossarm on the ship's highest mast.

3.3 Mounting

After inserting the plug connector into the socket at the bottom of the sensor shaft, the sensor is mounted on a fitting tube with an outer diameter of 50 mm and an inner diameter at least 40 mm. If a traverse is supplied for the sensor 24513-NMEA then the fitting tube is a part of the traverse.

Before the screws of the sensor are tightened, the sensor must be adjusted to north.

In order to install the wind sensor fast and correct regarding the north-adjustment this item is equipped with an integrated mounting aid. Inside the inner bottom of the sensor a small bolt pointing to the north is integrated to be set into a corresponding slot of the mounting pipe. Therefore the mast piece has to be designed with a corresponding slot as illustrated in the dimensional drawing.

Alternatively the correct north setting can be carried out by searching a point outside the vessel in the landscape which is located in the ship ahead direction respectively in the bow-stern line or a parallel line in case of the sensor is mounted far away from the middle line. The sensor finally can be fastened by means of the two hexagonal screws when the selected point in the outer terrain is in the view-finder (groove) of the sensor which is located on the top of its housing. Finally the earth screw has to be connected to the ship's ground. An acid-free contact grease is recommended to protect contact surfaces against corrosion.



Obey all safety instructions while setting up the sensor onto a mast.

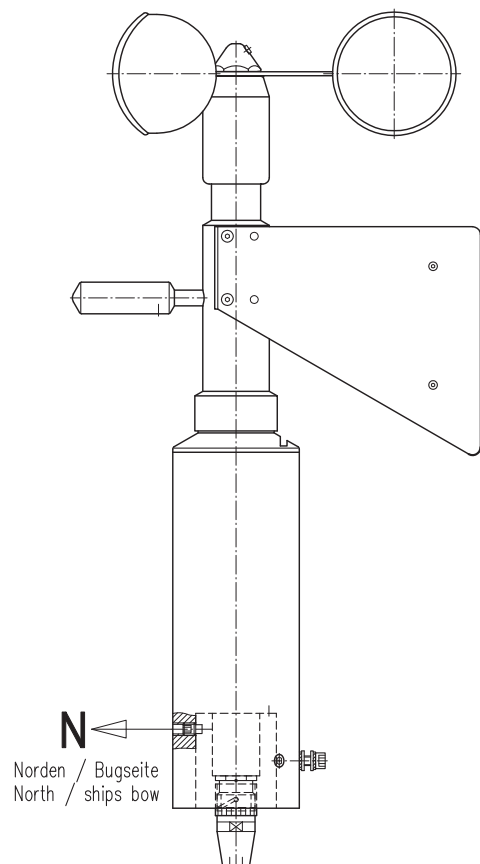

3.4 Electrical connection

The cable is connected to the sensor by means of a splash-proof plug connection in the shaft of the sensor. Before mounting the sensor on the fitting tube, the cable with the plug connector has to be passed through the tube. The electrical connection of the different models can be found in the wiring diagram. If the sensor is connected incorrectly, the sensor or connected components may be damaged.



The warranty for the device is excluded if damage occurs due to improper handling. This particularly includes the absence of proper grounding. Correct grounding according to DIN VDI/VDE 0100 is essential for the safety and functionality of the device. If you have any questions regarding installation, please contact us.

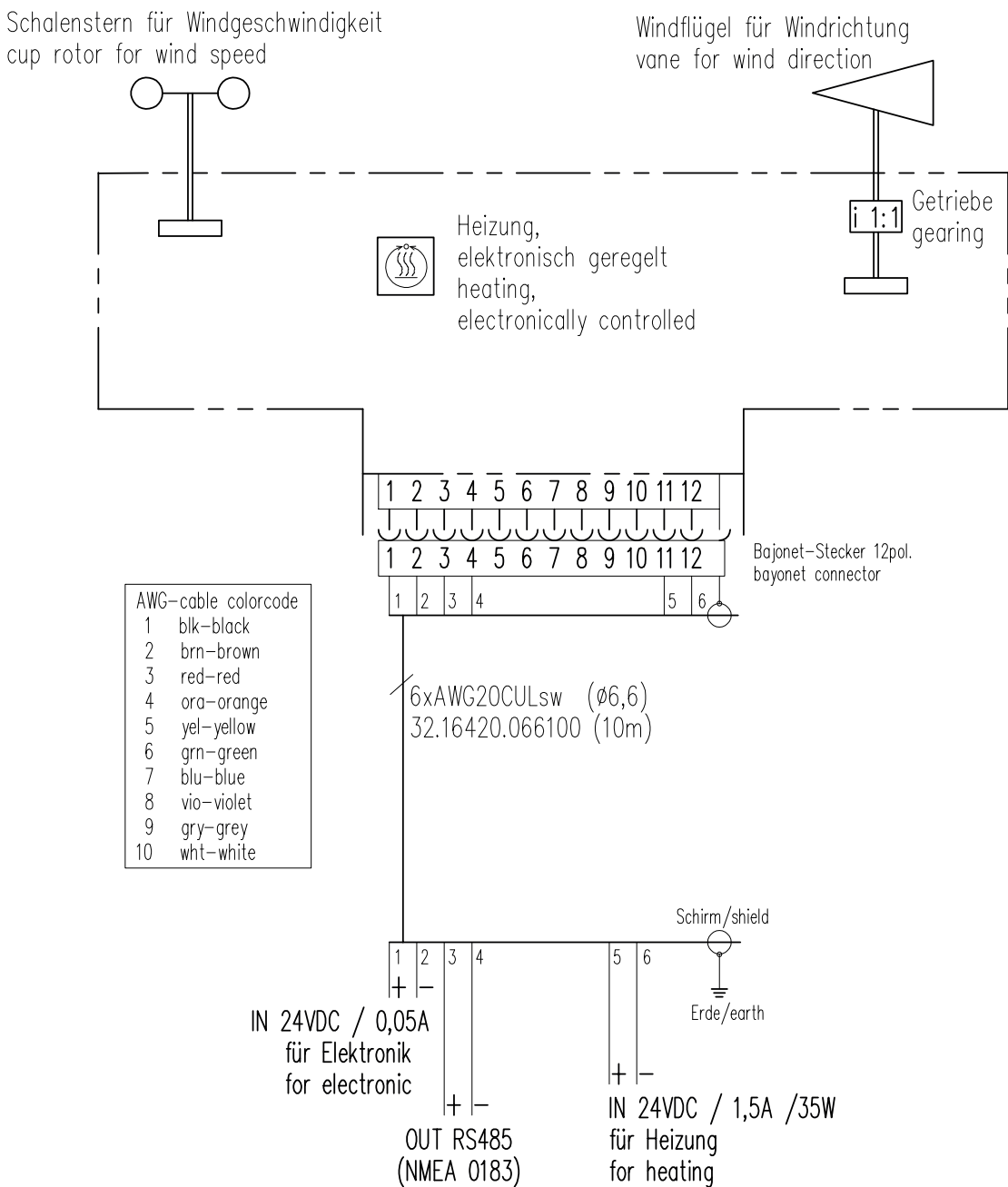

3.5 Cable entries

If the sensor is mounted in correct manner and connected with the right cable (accessory), you can attach the wires to power supply and signal outputs to data acquisition equipment (computer). The sensor requires a 12-pole CONINVERS plug connector of the series designation „TC“ (Ordering No.: TC-12S1N128055). The cable shield should be connected with both ends at the ground wire (PE).



To reduce the risk of inductive interference the sensor must be properly grounded (screening on both sides).

3.6 Start-up

After having finished the electrical and mechanical installation work of this item as mentioned in this manual and other related instructions the wiring should be checked once again before switching on the mains for the whole measuring system. When the power supply of the sensor is switched on, the sensor automatically sends cyclic data.

3.7 Functional test

When the system installation is completed a simple performance check as mentioned here can be carried out:

- To check the sensor for wind direction the wind vane is set in the directions NORTH-EAST-SOUTH-WEST and fixed in these positions for a while. Accordingly to this directions the following values must be displayed: N or 0° (360°), E or 90°, S or 180°, W or 270°.

If the display does not correspond to the actual positions of the wind vane, the sensor must be aligned again and the cable connections checked.

- When stopping the cup rotor carefully by hand at its axis, the displays must indicate a value of 0 knots (m/s).

4 Service and maintenance

4.1 Replacement of spare parts

REPLACEMENT OF EXTERNAL PARTS

When working under harsh conditions it may be necessary that the following consumables have to be replaced.

Cup Rotor: After bending away the washer, the hexagonal screw can be loosened with a wrench size SW 27. The faulty cup rotor can be removed together with the washer.

The new cup rotor has to be mounted in such way that the concave parts of the cups are always on the right side enabling an **anticlockwise rotation**.

After replacement of a cup rotor it will always be necessary to use a new washer in order to fix the rotor safely. New balancing will not be required.



Wind Vane: The wind vane blades can be removed after loosening the three screws of each blade. After mounting of the new parts the wind vane has to be balanced. For this purpose the sensor must be held in a horizontal position (90° shifted from the position during normal operation). If the balancing is correct, the vane will be stable in every position. The adjustment can be made with the weight at the end opposite of the vane. It can be moved after loosening the threaded pin. Please be sure that all screws are fixed before mounting the sensor on the mast again.

4.2 Repair procedures

The fault tracing and service work only should be carried out by skilled maintenance personnel having passed a factory training at our facilities or a similar course. All spares of the sensor mentioned here which cannot be repaired have to be disposed appropriately according to the local instructions of the waste management. For all other repairs which cannot be carried out by own staff the sensor has to be returned to our factory. The full shipping address of our company is mentioned in this operating instructions.

4.3 Ordering spare parts

In case that the mentioned spares are required for replacement or to be put on stock, please pass us the following information in order to send the right spare parts:

- Ordering number/parts number
- Required quantity
- Related component or name of higher assembly

A detailed inquiry containing these information will be appreciated by us for the safe identification of the required items and to prevent wrong deliveries. Above mentioned data can be obtained from the designation label.

5.0 Set device out of operation

5.1 Storage

The wind sensor 24513-NMEA has to be stored in a clean and dust free room with temperatures between -40 and 60 °C (not condensing) in the original cardbox or a similar packing.

5.2 Dispatch

We recommend using the original box or similar packaging for shipping. To prevent damage during transport, the wind vane and the cup rotor must be protected.

5.3 Remarks

This manual describes the standard design as well as possible options. The respective performance will be stated in the specification and/or the commercial documents of the contract. Our products are subject to continuous developments. Technical alterations for the technical progress are reserved.

6 Disposal

LAMBRECHT meteo GmbH is listed and registered at the Stiftung Elektro-Altgeräte Register ear under:

WEEE-Reg.-Nr. DE 45445814

In the category of monitoring and control instruments, device type: "Monitoring and control instruments for exclusively commercial use".

Within the EU



The device has to be disposed according to the European Directives 2002/96/EC and 2003/108/EC (Waste Electrical and Electronic Equipment). Do not dispose the old device in the household waste! For an environmentally friendly recycling and disposal of your old device, contact a certified disposal company for electronic waste.

Outside the EU

Please follow the regulations in your country regarding the appropriate disposal of waste electronic equipment.

7 Overview spare parts

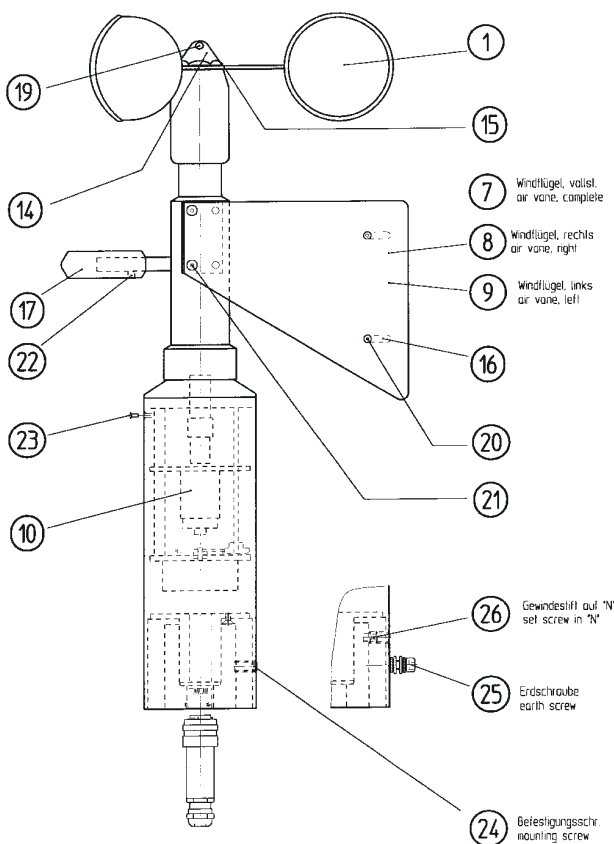

Ersatzteilliste			
Pos.	Beschreibung	Anzahl	Bauteilnr.
1	Schalenstern Cup rotor	1	32.14698.002030
7	Windflügel, vollst. Complete vane	1	32.14513.017000
8	Windflügel, rechts, schwarz (RAL 9005) Right vane, black	1	32.14513.018010
9	Windflügel, links, schwarz (RAL 9005), Left vane, black	1	32.14513.018020
10	LP-Seriell PCB seriell	1	32.14513.040000
14	Kappe Cap	1	33.14676.015000
15	Sicherungsblech Locking plate	1	33.14676.017000
16	Strebe, schwarz (RAL 9005) Brace, black	2	33.14511.160030
17	Gewicht, schwarz (RAL 9005) Weight, black	1	33.14511.051010
19	Zyl.-Schraube M3x4, rot Head screw M3x4, red plastic	1	35.00842.418201
20	Halbrundschraube M3x8 ISO 7380 Half-round screw M3x8 ISO 7380	4	35.73801.518501
21	Halbrundschraube M4x8 ISO 7380 Half-round screw M4x8 ISO 7380	4	35.73801.249000
22	Gewindestift M5x5 Set screw M5x5	1	35.05511.529990
23	Senkschraube M2,5x6 Countersunk screw M2.5x6	1	35.09631.514200
24	Gewindestift M8x16 Hexagon socket screw M8x16	2	35.091312.540100
25	J-Sechskantschraube M8x16 Set screw M8x16	1	35.09121.533600
26	Gewindestift M8x10 Hexagon socket screw M8x10	1	35.90151.539800

8 Technical data

Combined wind sensor 24513 – NMEA	
ID	00.24513.205010
Parameters	
Wind direction	
Measuring element	Wedge-shaped wind vane
Measuring range	0...360°
Accuracy	± 2.5°
Resolution	< 1°
Starting value	< 0.8 m/s related to a deflection of the wind vane of 90°
Wind speed	
Measuring element	Three-armed cup rotor
Measuring range	0.4...60 m/s
Accuracy	± 2 % FS
Resolution	0.1 m/s
Starting value	≤ 0.4 m/s
General specifications	
Range of application	Temperature: -35..+70 °C (heated); wind speed: 0...60 m/s
Protocol	NMEA 0183; WIMWV
Interface	Serial RS 485/Talker Baud rate 4800; 1 Hz (at measuring cycle 4 Hz); 8 N1
Supply voltage	24 VDC / 50 mA; heating 24 VDC / 1.5 A / max. 35 VA / electronically controlled
Housing	Seawater resistant aluminium
Dimensions	Cup rotor Ø 280 mm; H 520 mm; for mounting pipe Ø 50 mm
Weight	2.7 kg
Accessories (please order separately)	
ID 32.16420.066100	Sensor cable; 10 m (other lengths available); 12-pole bayonet plug
Options	
ID 36.09340.000000	Visualization and evaluation software MeteoWare-CS3
ID 00.95800.010000	Data logger met[LOG]
ID 00.14742.301002	Display unit METEO-LCD/NAV