



USER MANUAL

# EOLOS-IND Modbus

Static Weather Sensor



## Contents

1.	Introduction	3
1.1.	Warranty	3
1.2.	Advantages of the static measuring principle	3
2.	Setting to work	4
2.1.	General installation conditions	4
2.2.	Tools and installation aids	5
2.3.	Unpacking the sensor	5
2.4.	Goods inspection	5
2.5.	Power supply	5
2.5.1.	Power input	5
2.5.2.	Protection	6
2.6.	Installation procedure (short instruction)	6
2.7.	Mounting	6
2.7.1.	North alignment of wind sensor	6
2.7.2.	Power and signal connection	7
2.7.3.	Safety regulations	7
3.	Maintenance	7
3.1.	Regular maintenance and calibration	7
3.2.	Visual check and cleaning	8
4.	Transports	8
5.	Dimensional drawings and electrical connections	9
6.	Modbus data protocols	11
6.1.	General	11
6.2.	Data Encoding	11
6.3.	Standard configuration - Default	11
6.4.	Available Modbus commands	12
6.5.	Instantaneous values / Realtime values (Input register)	12
6.6.	Period data - Average, maximum, and minimum (Input register)	12
6.7.	Descriptive sensor parameter registers (Holding register)	14
6.8.	Configuration registers (Holding register)	14
6.9.	Autoconfiguration	15
7.	Disposal	15
8.	Technical data	16

# 1. Introduction

The sensors of the EOLOS family are very robust, compact and extremely reliable. When developing these sensors particular consideration has been given to highest quality for fulfilment of meteorological requirements.

The system acquires the horizontal air flow and processes the measuring data to the meteorological parameters wind speed and wind direction. Furthermore the weather-module of the EOLOS-IND acquires the meteorological parameters air temperature, relative humidity and barometric pressure. The EOLOS-IND uses the measured data to calculate the dew point temperature and makes it available together with the measured values.

The sensors and further system components are mounted in a splash water- and dust proof metal housing. Due to their shock- and vibration proof construction the sensor EOLOS-IND is particularly qualified for use under severe environmental conditions. The housing is made of anodized seawater resistant aluminium.

## 1.1. Warranty

**Please note the loss of warranty and non-liability by unauthorised manipulation of the system. You need a written permission of the LAMBRECHT meteo GmbH for changes of system components. These activities must be operated by a qualified technician.**

The warranty does not cover:

1. Mechanical damages caused by external impacts (e. g. icefall, rockfall, vandalism).
2. Impacts or damages caused by over-voltages or electromagnetic fields which are beyond the standards and specifications in the technical data.
3. Damages caused by improper handling, e. g. by wrong tools, incorrect installation, incorrect electrical installation (false polarity) etc.
4. Damages which are caused by using the device beyond the specified operation conditions.

## 1.2. Advantages of the static measuring principle

The sensor EOLOS-IND is a modern system to carry out precise and reliable measurements under hardest application and environmental conditions. The wind measurements take place according to the principle "TAV" (thermal aura field variation), i. e. static, without moving parts.

**Static measuring principle** for wind measurements means:

- Determination of data works without moving measuring elements, i.e. none abrasion, least maintenance and none recalibration because of this method.
- Lightweight mass and immovable measuring elements to enable very low starting values, distance- and attenuation constants as well as a very high repetition accuracy.
- The compact sensor is easy to install. Minor deviations from the vertical (pitch) can be neglected with this measurement principle.

**Advantages of the sensor:**

- Additional integrated sensors for air temperature, relative humidity, and barometric air pressure. The dew point temperature is calculated accordingly.
- The compact design of this sensor with 5 meteorological parameters is eliminating the traditional cabling and installation work significantly. Distribution boxes, power supply units; and other accessories can be reduced to a minimum expense.

## 2. Setting to work

Wind can be represented by a vector quantity. For a complete description of the wind it is necessary to specify its speed and direction. The two components are subject to spatial and temporal variations; thus, strictly speaking, they are valid only for the site where the measuring instrument is installed. We therefore recommend selecting the place of installation very carefully.

### 2.1. General installation conditions

For professional wind measurements according to meteorological standards (e. g. VDI 3786, Part 2) location and height of the wind sensor are important for representative and accurate results. Generally, wind measuring instruments should not measure the specific wind conditions of a limited area, but indicate the typical wind conditions of a wider area. To obtain results which are representative for a wider area and comparable to values measured at different places, the sensor must not be mounted under the lee of higher obstacles. The distance to any obstacle should be at least 10 times the obstacle's height (corresponding to the definition of an undisturbed area). In general a measuring height of 10 m above ground is regarded ideal.

If an undisturbed terrain of this kind does not exist the sensor have to be put up at an height of at least 6 m above the obstacle height. If the above mentioned requirements are not feasible e. g. on mobile measurements at vehicles or at measuring containers compromises have to be found and documented.

If the sensor must be installed on a roof top the place of installation must be in the middle of the roof to avoid predominant wind directions. If you want to measure both wind direction and wind speed, it is recommended to mount both sensors at the same spot, where any interaction between the sensors should be avoided. The sensor EOLOS-IND easily meets this requirement.



The place of installation should **not** be in the operation fields of radar devices (radar scanners or radar transmitters), generators or antennas. We recommend a minimum distance of 2 m to these installations. Furthermore a minimum distance of 5 m to MF-/HF- and Satcom- (e. g. Inmatsat, VSat) antennas has to be kept. The maximum electric field intensity may not exceed 10 V/m (tested according to EMC standard). When indicated a greater distance should be kept.

To avoid possible measurement errors due to heat sources as hot or warm fumes, hot surfaces etc. next to the sensor, the mounting site should be chosen accordingly.

## 2.2. Tools and installation aids

There are no special tools or materials required for the installation works. All work can be carried out with standard tools available in a regular workshop.

## 2.3. Unpacking the sensor

The sensor is packed in a separate box, carefully protected against mechanical influences during transport.

Please verify that the following parts and documents are enclosed:

- 1x sensor EOLOS-IND Modbus
- 1x user manual

Accessories: (depend on order size, in all cases separately packed)

Connecting cable with plug and core cable ends

## 2.4. Goods inspection

Please thoroughly check the delivery with regard to completeness and eventual transport damages. In case of eventual claims please contact us in writing immediately.

## 2.5. Power supply

The compact sensor requires 24 VDC as a power supply for the electronics.

### 2.5.1. Power input

The power input of the EOLOS reaches its peak in the start-up period (activation phase). The maximum of the power input is 2.5 A. In normal operation the average power input is significantly lower (see table). The power input mainly depends on the flow rate.

Wind speed	Ø Power input
0 m/s	500 mA
5 m/s	650 mA
20 m/s	900 mA
38 m/s	1100 mA
Measured at a supply voltage of 24 VDC and 20 °C	

## 2.5.2. Protection

Generally it is not necessary to protect the secondary side (24 V DC) of the EOLOS. Normally only the primary side has to be protected. However, if additional protection for the supply is desired, we recommend using a micro-fuse 3.15 A - medium time-lag.

## 2.6. Installation procedure (short instruction)

The installation of the sensor involves 3 steps:

1. Mounting the cable at the sensor and if necessary draw the cable through the mast.
2. Mounting the sensor at the mast, but before tightening the screws you must align the sensor to the north.
3. Attaching the cable to the power supply and the signal acquisition system.

## 2.7. Mounting

The sensor can be installed on a standard pipe with an outer diameter of 50 mm and an inner diameter of maximum 40 mm. Before tightening the two 8 mm-socket screws and attaching the sensor you have to draw the cable through the pipe and align the sensor into driving direction.

For this purpose the housing is marked accordingly (see drawing). Before the screws of the sensor are tightened, the sensor is adjusted to north. In addition the sensor has a pin for the north direction. You can put this pin into the nick at the mast (if available). If needed you can turn in or unscrew the pin by means of allen key.



Please pay attention to a firm mounting of the sensor at the mast!

### 2.7.1. North alignment of wind sensor

For wind direction measurements the north mark on the sensor must be aligned with the geographical north direction. To adjust the wind sensor in a firm and correct manner into the north direction this item is equipped with an integrated mounting aid. Inside the inner bottom of the sensor a small bolt pointing to the north is integrated to be set into a corresponding slot of the mounting pipe (if available). Thus the sensor is safely attached. If needed you can turn in or unscrew the pin by means of allen key.

To set up the sensor's north orientation select a landmark which is as far as possible up north with regard to the final position of the wind direction sensor. The reference point can be selected using a topographical map (1:25000). The exact position of the reference point is determined using an amplitude compass that can be adjusted horizontally on a stand.



Compass declination has to be considered!



Follow all safety instructions while setting up the sensor onto a mast.



## 2.7.2. Power and signal connection

For the electrical connection of the sensor, a 4-pole M12 connector is required. The shielding of the cable should be connected to the protective earth (PE).



To reduce the risk of inductive interference the sensor must be properly grounded (screening on both sides).

The external connection is via central connector which is located in housing base. For further details about electrical connection please see chapter "Connecting diagrams". If the sensor is mounted in correct manner and connected with the right cable (accessory), you can attach the wires to power supply and signal outputs to data acquisition equipment (computer).

The typical power supply requirements of the EOLOS-IND sensor are 24 Volts with a maximum current drain of 2.5 A. The input range is max. 18... 32 VDC.

The output signal of the sensor corresponds to the RS-485 standard. The signal levels allow transmission via shielded signal cables up to a maximum length of 1,200 meters or 4,000 feet. The cable lengths depend on the quality of the cables used. When the power supply of the sensor is switched on, after 30 seconds (in order to reach operating temperature) the sensor cyclically starts sending data protocols.

## 2.7.3. Safety regulations



Since the sensor is often installed at high altitudes, the relevant safety regulations must be observed during installation work. During electrical installation work, the corresponding circuits must be de-energized.

The housing may only be opened by authorized personnel

# 3. Maintenance

## 3.1. Regular maintenance and calibration

The EOLOS-IND Modbus sensor is designed to be low-maintenance and to have a long service life. It is recommended that you perform regular visual inspections for weather-related surface contamination and, if necessary, carry out cleaning. Regular visual and functional checks of the wind sensors are also recommended



If reference measurements are required, it is essential to ensure that comparability of the measurement values is only possible if the measurements are taken under the same conditions. This means that the reference device must be used in close proximity to the sensor!

The sensor is a measuring instrument and thus apply user specific standards regarding period of recalibration. Recommendation: 2 years.

We recommend to have the filter cap of the humidity-temperature sensor every two years exchanged in our plant. Depending on the application shorter maintenance cycles could be necessary.

## 3.2. Visual check and cleaning

The use of the sensor under the respective environmental conditions requires certain steps. It is thus recommendable to clean the outside of the housing and shelter within specific intervals. The intervals are dependant on the environmental conditions and the degree of soiling. We recommend a regular sight and functional check.

In case you should be faced with any specific problems please contact the LAMBRECHT meteo service under:

Tel: +49-(0)551-4958-0

E-mail: [support-lambrecht@aem.eco](mailto:support-lambrecht@aem.eco)

## 4. Transports

In case it is necessary to ship or to transport the sensor must be carefully packed to prevent damages during transport.



## 5. Dimensional drawings and electrical connections

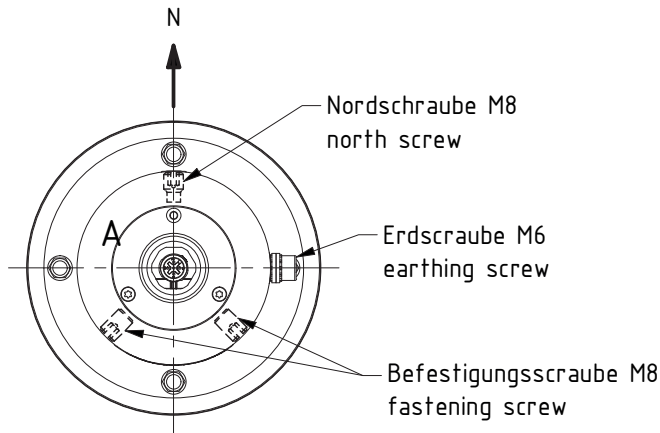

A ( 1 : 1 )

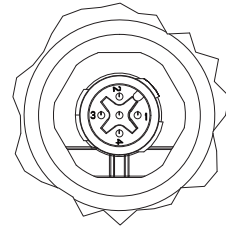

Ansicht Steckerseite  
view male side

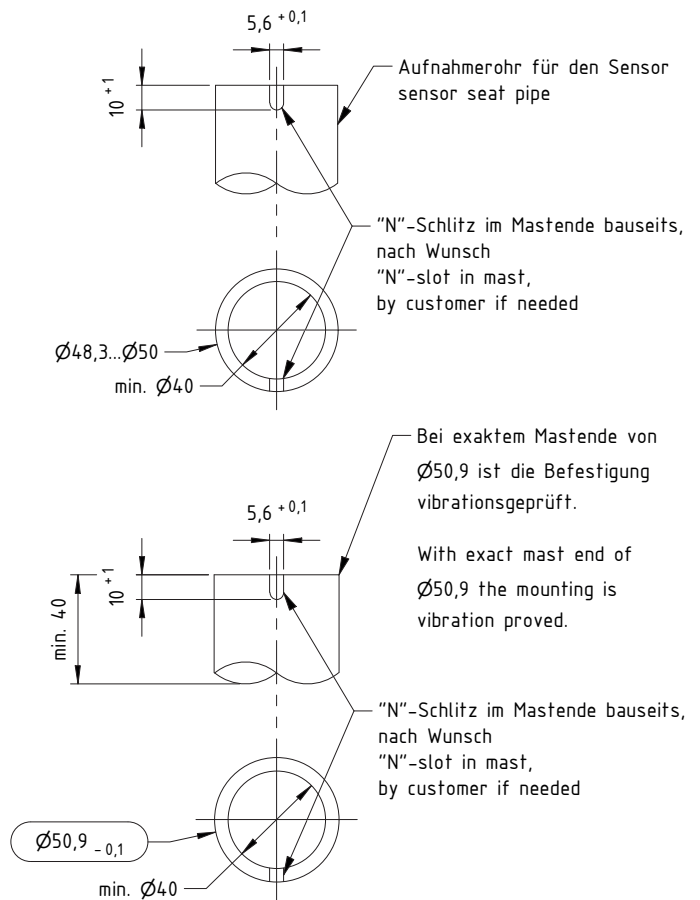
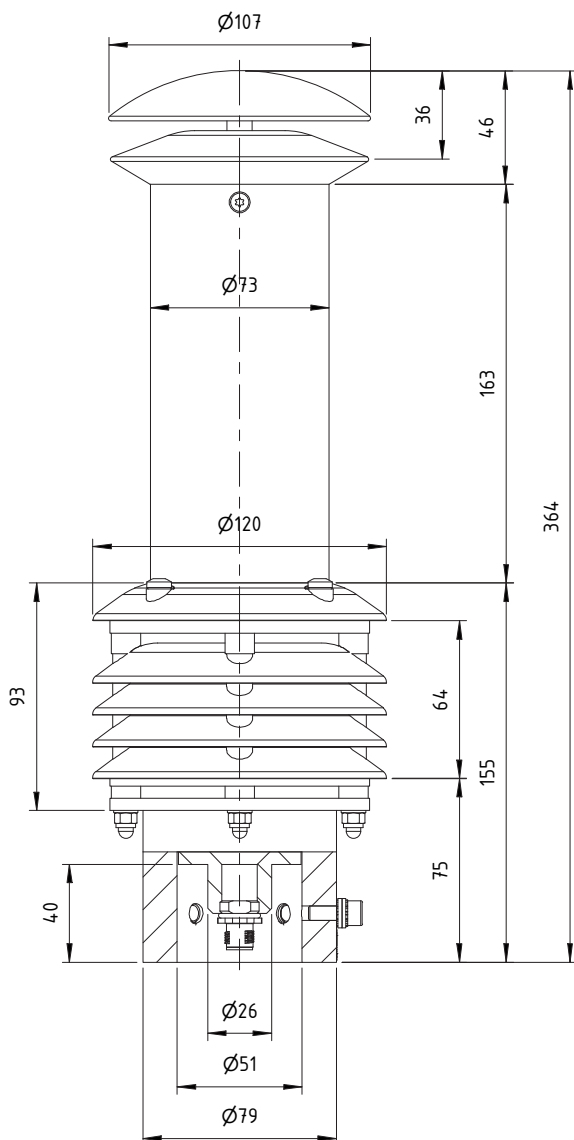

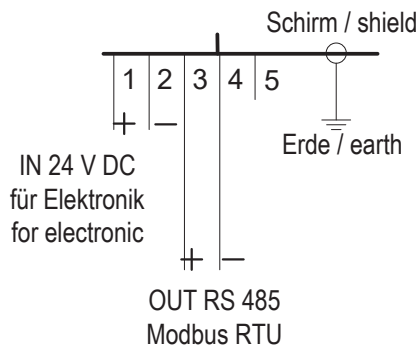
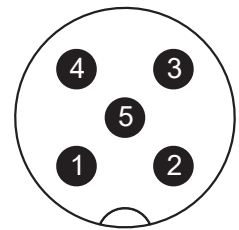
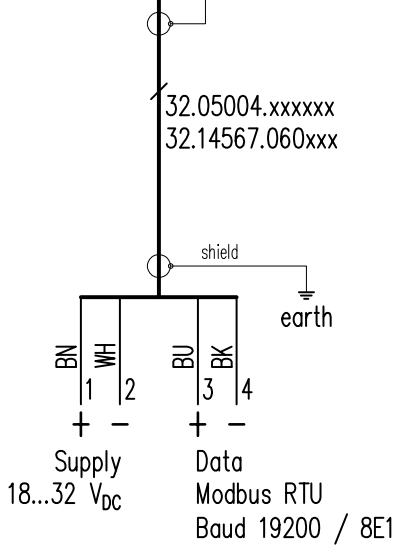
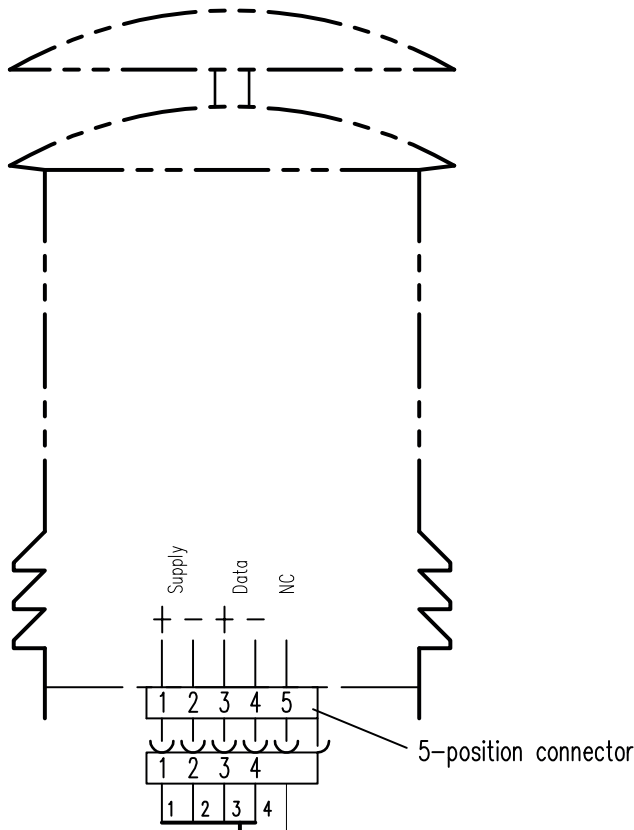

PIN	color	Farbe
1	br	br
2	wt	ws
3	bl	bl
4	bk	sw
5	N/A	N/A

## 6. Modbus data protocols

### 6.1. General

The LAMBRECHT meteo Modbus sensors follow the specification of the Modbus organization: “MODBUS APPLICATION PROTOCOL SPECIFICATION V1.1b3” (see [www.modbus.org](http://www.modbus.org)).

### 6.2. Data Encoding

MODBUS uses the “Big-Endian” format for addresses and data. This means that if a value is transmitted with a number format which is larger than a single byte, that the “most significant byte” is sent first.

#### Example Big-Endian:

Register size value 16 - bits

0x1234 is transmitted in the sequence: 0x12 0x34.

To obtain the real measuring value, divide the received register value by the divisor.  
Values of -9999 indicate an internal sensor error.

### 6.3. Standard configuration - Default

Baud rate: 19200 Baud

Byte frame: 8E1 (1 start bit, 8 data bits, 1 parity bit (even parity), 1 stop bit)

RTU Sensor address: 5

#### DEFAULT ADDRESSES OF THE LAMBRECHT SENSORS

Address	Sensor
1	Wind speed
2	Wind direction
3	Precipitation rain[e]
4	THP
5	EOLOS IND; u[sonic]WS6
6	com[b]
7	PREOS
8	ARCO
9	u[sonic]
10	Pyranometer 2nd Class
11	Secondary standard Pyranometer
12	PT100 to Modbus converter (temperature)
13	u[sonic]WS7
14	IceLoad Sensor

## 6.4. Available Modbus commands

The LAMBRECHT Modbus sensors support the following commands:

- “Read Holding Register” command: 0x03 (descriptive sensor data registers)
- “Read Input Register” command: 0x04 (measured values registers)  
(every measured value is to be requested individually)
- “Write Multiple Register” command: 0x10 (Write to configuration registers)

## 6.5. Instantaneous values / Realtime values (Input register)

The following measured values are provided:

Register address	Parameter name	Unit	Divisor	Quantity of registers	Access type
30001	Wind speed	m/s	10	1	Read only
30201	Wind direction	°	10	1	Read only
30401	Air temperature	°C	10	1	Read only
30601	Relative humidity	% r. F.	10	1	Read only
30701	Dew point	°C	10	1	Read only
30801	Air pressure	hPa	10		Read only

Example: Retrieve wind speed

0D	04	75	31	00	01	7A	C5	0D	04	02	00	1F	E8	F9
----	----	----	----	----	----	----	----	----	----	----	----	----	----	----

LEN 6	Transmission Query =>	Source Master	Dest Slave 13	Function Read Input Register (4)	Func Desk Address=30001, Quantity of Register=1	Checksum OK:C57A
----------	--------------------------	------------------	------------------	-------------------------------------	--	---------------------

LEN 5	Transmission Response <=	Source Slave 13	Dest Master	Function Read Input Register (4)	Func Desk Byte count=2	Data 00 1F	Checksum OK:F9E8
----------	-----------------------------	--------------------	----------------	-------------------------------------	---------------------------	---------------	---------------------

## 6.6. Period data - Average, maximum, and minimum (Input register)

Register	Parameter name	Unit	Divisor	Quantity of registers	Access type
30002	Wind speed average	m/s	10	1	Read only
30003	Wind speed maximum	m/s	10	1	Read only
30004	Wind speed minimum	m/s	10	1	Read only
30202	Wind direction average	°	10	1	Read only
30203	Wind direction maximum	°	10	1	Read only
30204	Wind direction minimum	°	10	1	Read only
30402	Air temperature average	°C	10	1	Read only
30403	Air temperature maximum	°C	10	1	Read only
30404	Air temperature minimum	°C	10	1	Read only
30602	Relative humidity average	% r. F.	10	1	Read only
30603	Relative humidity maximum	% r. F.	10	1	Read only

30604	Relative humidity minimum	% r. F.	10	1	Read only
30702	Dew point average	°C	10	1	Read only
30703	Dew point maximum	°C	10	1	Read only
30704	Dew point minimum	°C	10	1	Read only
30802	Air pressure average	hPa	10	1	Read only
30803	Air pressure maximum	hPa	10	1	Read only
30804	Air pressure minimum	hPa	10	1	Read only

The data are valid for the period between the current request and the previous request. The maximum range of a period is 1 hour. Recalling the average value of a minimum, maximum and average group will erase the appropriate registers.

Retrieve the values of a group in the sequence minimum, maximum, average.

Use command: 0x03

Example: Retrieve wind speed (min. max. avr.) and erase the register content

01	04	75	34	00	01	6A	08	01	04	02	00	00	B9	30	01
04	75	33	00	01	DB	C9	01	04	02	00	D6	38	AE	01	04
75	32	00	01	8A	09	01	04	02	00	14	B9	3F			

LEN 6	Transmission Query =>	Source Master	Dest Slave 1	Function Read Input Register (4)	Func Desk Address=30004, Quantity of Register=1	Checksum OK:86A
LEN 5	Transmission Response <=	Source Slave 1	Dest Master	Function Read Input Register (4)	Func Desk Byte count=2	Data 00 00 Checksum OK:30B9
LEN 6	Transmission Query =>	Source Master	Dest Slave 1	Function Read Input Register (4)	Func Desk Address=30003, Quantity of Register=1	Checksum OK:C9DB
LEN 5	Transmission Response <=	Source Slave 1	Dest Master	Function Read Input Register (4)	Func Desk Byte count=2	Data 00 D6 Checksum OK:AE38
LEN 6	Transmission Query =>	Source Master	Dest Slave 1	Function Read Input Register (4)	Func Desk Address=30002, Quantity of Register=1	Checksum OK:98A
LEN 5	Transmission Response <=	Source Slave 1	Dest Master	Function Read Input Register (4)	Func Desk Byte count=2	Data 00 14 Checksum OK:3FB9

### 6.7. Descriptive sensor parameter registers (Holding register)

Register	Parameter name	Quantity of registers	Remark	Access type
40050	Device identification number (15 characters)	8 (2 characters in each register)	The returned data are in form of a 16 byte null terminated string	Read only
40100	Serial number (11 characters)	6 (2 characters in each register)	The returned data are in form of a 12 byte null terminated string	Read only
40150	Firmware version (up to 25 characters)	13 (2 characters in each register)	The returned data are in form of a 26 byte null terminated string	Read only

Example: Retrieve the device identification number

(The identification number shown in the example is sensor-dependent. It is only used here for demonstration purposes).

0D	03	9C	72	00	08	CA	8B	0D	03	10	30	30	2E	31	36	□□□□□□□□□□□□□□
34	38	30	2E	30	30	31	31	33	30	00	E8	6B				00.16480.000130□□□□

LEN 6	Transmission Query =>	Source Master	Dest Slave 13	Function Read Holding Register (3)	Func Desk Address=40050, Quantity of Register=8	Checksum OK:8BCA	
LEN 19	Transmission Response <=	Source Slave 13	Dest Master	Function Read Holding Register (3)	Func Desk Byte count=16	Data 30 30 2E 31 36 34 38 30 2E 30 30 31 31 33 30 00	Checksum OK:6BE8

### 6.8. Configuration registers (Holding register)

Register	Parameter name	Allowed values	Quantity of registers	Access type
40001	Modbus device address		1	Write only
40200	Baud rate	96 = 9600 192 = 19200 384 = 38400	1	Write only
40201	Parity	1 = even 0 = none	1	Write only

The device must be restarted after each change of a setting!

Example: Change the RTU address from 4 to 1

05	10	9C	41	00	01	02	00	01	06	48	05	10	9C	41	00
01	7E	09													

LEN 9	Transmission Query =>	Source Master	Dest Slave 5	Function Write Multiple Register (16)	Func Desk Address=40001, Quantity=1	Byte count 2	Register values 00 01	Checksum OK:4806
LEN 6	Transmission Response <=	Source Slave 5	Dest Master	Function Write Multiple Register (16)	Func Desk Address=40001, Quantity=1	Checksum OK:097E		

## 6.9. Autoconfiguration

All LAMBRECHT Modbus sensors offer the experienced user the possibility to implement an auto-configuration in his Modbus master based on additional information stored in the sensor.

The necessary information can be found in the document “Lambrecht\_Modbus\_Autoconfiguration”.

## 7. Disposal

LAMBRECHT meteo GmbH is listed and registered at the Stiftung Elektro-Altgeräte Register ear under:

**WEEE-Reg.-Nr. DE 45445814**

In the category of monitoring and control instruments, device type: “Monitoring and control instruments for exclusively commercial use”.

### Within the EU



The device has to be disposed according to the European Directives 2002/96/EC and 2003/108/EC (Waste Electrical and Electronic Equipment). Do not dispose the old device in the household waste! For an environmentally friendly recycling and disposal of your old device, contact a certified disposal company for electronic waste.

### Outside the EU

Please follow the regulations in your country regarding the appropriate disposal of waste electronic equipment.

## 8. Technical data

### (1643) Static Weather Sensor EOLOS-IND Modbus – ID No. 00.16430.001032

Range of application:      Temperature: -40...+70 °C  
    Wind speed: 0...100 m/s  
    Relative humidity: 0...100 % r. h.

#### PARAMETERS

##### Wind direction

Measuring range:    0...360°  
 Accuracy:            3° RMS  
 Resolution:          1°

##### Wind speed

Measuring range:    0.1...50 m/s  
 Accuracy:            0.5 m/s ± 5 % RMS of the measuring value; at 5.1...40 m/s  
 Resolution:          0.1 m/s

##### Temperature

Measuring range:    -40...+70 °C  
 Accuracy:            ± 0.8 °C (v > 2 m/s)<sup>1)</sup>  
 Resolution:          0.1 °C

##### Relative humidity

Measuring range:    0...100 % r. h.  
 Accuracy:            ± 3 % (10...90 %) r. h. <sup>2)3)</sup>; ± 4 % (0...100 %) r. h.  
 Resolution:          0.5 % r. h.

##### Barometric pressure

Measuring range:    600...1100 hPa  
 Accuracy:            ± 2 hPa (-30...+70 °C)  
 Resolution:          0.1 hPa

Protocols:            Modbus RTU  
 Supply voltage:      24 VDC<sup>4)</sup>; max. 2.5 A  
 Housing:             Aluminium, anodized; IP 66  
 Dimensions:         H 382 mm, Ø 120 mm; mast adapter Ø 50 mm for mounting on standard pipe  
 Weight:                Approx. 2.5 kg  
 Interface:             Serial, RS-485, Baud rate 16200; 8 E 1

#### STANDARDS

- NMEA 0183
- Standard of construction: VDE 0100
- Low voltage guide line: 72/23 EWG
- EMC/EMI: DIN EN 60945 and DIN EN 61000-4-2, 3, 4, 6, 11
- Salt fog: EN 60945
- Protection class: DIN EN 60529
- Vibration: BV 0240

<sup>1)</sup>Temperature influence of the shelter: accuracy +1.5 °C at v < 2 m/s and intensive solar radiation

<sup>2)</sup>Temperature influence of the shelter: ± 0.1 % r.h. at +10...+40 °C

<sup>3)</sup>Shelter inaccuracy: < 4 % r.h. dependant on v > 2 m/s and solar radiation

<sup>4)</sup>At sensor connector; when connected to a LAMBRECHT standard cable (15 m) the supply voltage range on the side of the power supply switches to 18.7...32 VDC. When using other cables and cable lengths the individual voltage drop has to be considered.



**ACCESSORIES (PLEASE ORDER SEPARATELY)**

**ID 32.14567.060000** Sensor cable, 12 m; 4 pole

**OPTIONS (PLEASE ORDER SEPARATELY)**

**ID 00.95800.010000** Data logger met[LOG]

**ID 00.95770.000000** Data logger Ser[LOG]

Copyright © 2024 LAMBRECHT meteo GmbH. All rights reserved.  
Information in this document subject to change without notice.  
Photo copyright: © elxeneize - Adobe stock

1643x\_IND\_Modbus\_b-de.indd 48.24

**LAMBRECHT meteo GmbH**  
**Friedländer Weg 65**  
**37085 Göttingen**  
**Germany**

Tel +49-(0)551-4958-0  
Fax +49-(0)551-4958-312  
E-Mail [info-lambrecht@aem.eco](mailto:info-lambrecht@aem.eco)  
Internet [www.lambrecht.net](http://www.lambrecht.net)

