



USER MANUAL

u[sonic] Modbus

Ultrasonic Wind Sensor



Content

1	u[sonic] Modbus - Advantages at a glance	3
2	Warranty	3
3	Introduction	3
4	Start-up	4
4.1	Installation conditions	4
4.2	General	4
4.3	Tools and installation material	5
4.4	Unpacking the sensor	5
4.5	Incoming inspection	5
4.6	Energy supply	6
4.7	Current consumption	6
4.8	Installation work (short description)	6
4.9	Mounting the sensor	6
4.9.1	Sensor northing	6
4.9.2	Power supply and signal cables	7
4.9.3	Safety regulations	7
5	Maintenance	8
5.1	Regular maintenance and calibrations	8
5.2	Visual inspections and cleaning	8
6	Transports	8
7	Disposal	8
8	Dimensional drawing	9
9	Connection diagram	9
10	Modbus protocol	10
10.1	General	10
10.2	Data encoding	10
10.3	Standard configuration - Default	10
10.4	Available Modbus commands	11
10.5	Instantaneous values / real-time values (Input Registers)	11
10.6	Period data - Average, maximum and minimum (Input Registers)	12
10.7	Descriptive sensor parameter registers (Holding Registers)	13
10.8	Configuration registers (Holding Registers)	13
10.9	Autoconfiguration	14
11	Technical data	15

1 u[sonic] Modbus – Advantages at a glance

The ultrasonic wind sensor Modbus u[sonic] was specially designed for extreme environmental conditions. It comes without any moving measuring elements and is ideal for high wind speeds. The extreme robust, compact sensor has a high-quality, pollutant-resistant housing made of hard anodized aluminium and stainless steel.

- Three parameters in one device: wind direction, wind speed, virtual temperature
- Without movable measuring elements
- No abrasion, low maintenance
- Standard RS 485 interface with ESD protection
- Modbus data protocol
- Power supply (without heating) 6...60 VDC or 12...42 VAC
- Power supply (with heating) 24 V AC/DC \pm 20 %
- Simple, space-saving assembly on 50 mm standard pipe
- Heating power 60 W

2 Warranty

Please note the loss of warranty and non-liability by unauthorized manipulation of the system. You need a written permission of the LAMBRECHT meteo GmbH for changes of system components. These activities must be operated by a qualified technician.

The warranty does not cover:

1. Mechanical damages caused by external impacts (e. g. icefall, rockfall, vandalism).
2. Impacts or damages caused by over-voltages or electromagnetic fields which are beyond the standards and specifications in the technical data.
3. Damages caused by improper handling, e. g. by wrong tools, incorrect installation, incorrect electrical installation (e.g. false polarity) etc.
4. Damages which are caused by using the device beyond the specified operation conditions.

3 Introduction

The wind sensor u[sonic] Modbus is very robust, compact and extremely reliable. When developing this sensor particular consideration has been given to highest quality for fulfilment of meteorological requirements. The system acquires the horizontal air flow and processes the measuring data to the meteorological parameters wind speed and wind direction. The sensor is mounted in a splash water- and dust proof metal housing (IP66 and IP67) and can be immersed temporarily.

The measuring data are automatically transmitted via serial interface RS 485 in talker mode, when power supply is switched on. Due to their shock- and vibration proof construction the sensor u[sonic] is particularly qualified for use under severe environmental conditions. The housing is made of anodised seawater-resistant aluminium and stainless steel. An electronically controlled heating device enables the sensor to operate in between the wide range of -40 up to 70 °C.

ADVANTAGES OF THE STATIC MEASURING PRINCIPLE

The sensor u[sonic] is a modern system to carry out precise and reliable measurements under hardest application and environmental conditions. The wind measurements take place according to the principle “ultrasonic run-time measurement”, i. e. static, without moving parts.

Static measuring principle for wind measurements means:

- Determination of data works without moving measuring elements, i.e. none abrasion and least maintenance.
- The wind parameter can be measured also in winter time accurate and precise, because of the electronic controlled heating for the immovable measuring elements. This heating is particularly effective against ice and snow in all climatic zones.
- The measuring principle enables very low threshold values, distance- and attenuation constants as well as a very high repetition accuracy.

ADVANTAGES OF THE SENSOR

- The built-in test function of the station, enabled by the tight integration of the meteorological sensors into the enclosure, can perform cyclic self-testing and notify the user of erroneous data or failure.
- The compact design of the sensor u[sonic] with 3 meteorological parameters is eliminating the installation work significantly.

4 Start-up

Wind can be represented by a vector quantity. For a complete description of the wind it is necessary to specify its speed and direction. The two components are subject to spatial and temporal variations; thus, strictly speaking, they are valid only for the site where the measuring instrument is installed. We therefore recommend selecting the place of installation very carefully.

4.1 Installation conditions

4.2 General

For professional wind measurements location and height of the wind sensor are important for accurate, correct results and representative wind conditions. Ideally, the sensor should be installed in 10 m above the ground on a mast. This may be buildings, trees, tall towers, lifting cranes, moving vehicles, aircrafts, helicopters and other obstructions.



In case of mobile measurements at vehicles often above mentioned conditions are not practicable. Then you have to find compromises.

Generally, wind measuring instruments should not measure the specific wind conditions of a limited area, but indicate the typical wind conditions of a wider area. The values measured at different places must be comparable. Thus, when installing the sensor you should make sure the place of installation is not under the lee of great obstacles. The distance between the obstacles and the sensor should be 10 times the height of the obstacles (this corresponds to the definition of an undisturbed terrain). If an undisturbed terrain of this kind does not exist the sensor must be put up at a height of at least 6 m above the obstacle height.

If the sensor must be installed on a roof top the place of installation must be in the middle of the roof to avoid predominant wind directions. If you want to measure both wind direction and wind speed, the sensors should be avoided. The sensor u[sonic] easily meets this requirement.



The place of installation should not be in the operation fields of radar devices (radar scanners or radar transmitters), generators or antennas. We recommend a minimum distance of 2 m to these installations. Furthermore a minimum distance of 5 m to MF-/HF- and Satcom- (e. g. Inmatsat, VSat) antennas has to be kept. The maximum electric field intensity may not exceed 10 V/m (tested according to EMC standard). When indicated a greater distance should be kept.

4.3 Tools and installation material

There are no special tools or materials required for the installation works. All work can be carried out with standard tools, e.g. Allen key size 4.

4.4 Unpacking the sensor

The sensor is delivered in separate packaging, carefully protected against mechanical impact, to avoid damage during transport.

The package contains the following items:

- Sensor u[sonic]
- User manual

Accessories: (depending on the scope of delivery, packed separately if necessary)

Connection cable with cable plug

4.5 Incoming inspection

Please check the scope of delivery for completeness and possible transport damage. Please report any complaints immediately to us in writing.



4.6 Energy supply

The sensor requires at the input connector a 6...60 VDC or 12...42 VAC nominal power source for operation. For heating mode a 24 VAC/DC power supply is needed.

4.7 Current consumption

The current consumption of the u[sonic] is around approx. 25 mA at 24 VDC, without heating. With activated heating, the maximal current consumption is 2.5 A at 24 VDC.

4.8 Installation work (short description)

The sensor is installed in three steps:

1. Mounting the cable at the sensor and if necessary draw the cable through the mast.
2. Mounting the sensor at the mast, but before tightening the screws you must align the sensor to the north.
3. Attaching the cable to the power supply and the signal acquisition system.

4.9 Mounting the sensor

The sensor can be installed on a standard pipe with an outer diameter of 50 mm and an inner diameter of maximum 40 mm. Before tightening the two 8 mm-socket screws and attaching the sensor you have to draw the cable through the pipe and align the sensor into driving direction. For this purpose the housing is marked accordingly (see drawing). Before the screws of the sensor are tightened, the sensor is adjusted to north. In addition the sensor has a pin for the north direction. You can put this pin into the nick at the mast (if available). If needed you can turn in or unscrew the pin by means of allen key.



Please pay attention to a firm mounting of the sensor at the mast!

4.9.1 Sensor northing

For wind direction measurements the north mark on the sensor must be aligned with the geographical north direction. To adjust the wind sensor in a firm and correct manner into the north direction this item is equipped with an integrated mounting aid. Inside the inner bottom of the sensor a small bolt pointing to the north is integrated to be set into a corresponding slot of the mounting pipe (if available). Thus the sensor is safely attached. If needed you can turn in or unscrew the pin by means of allen key.

To set up the sensor's north orientation select a landmark which is as far as possible up north with regard to the final position of the wind direction sensor. The reference point can be selected using a topographical map (1:25000). The exact position of the reference point is determined using an amplitude compass that can be adjusted horizontally on a stand.





Compass declination has to be considered!

To align the sensor ahead (on ships) locate a point outside the ship in the landscape which is located in the ship ahead direction respectively in the centre line or in case of the sensor is mounted far away from the middle line a line parallel to the centre line. Once the sensor is adjusted, it can be fixed with the two hexagon socket screws. Finally the earth screw has to be connected to the ship's ground. Acid-free contact grease is recommended to protect contact surfaces against corrosion.



Follow all safety instructions while setting up the sensor onto a mast.

4.9.2 Power supply and signal cables

An 8-pole M16 cable connector is required for the electrical connection of the sensor. The shield of the cable must be clamped to the protective earth conductor (PE) at both ends.



The warranty for the device is excluded if damage occurs due to improper handling. This particularly includes the absence of proper grounding. Correct grounding according to DIN VDI/VDE 0100 is essential for the safety and functionality of the device. If you have any questions regarding installation, please contact us.

The external connection is via central connector which is located in housing base. For further details about electrical connection please see chapter „Connecting diagrams“. If the sensor is mounted in correct manner and connected with the right cable (accessory), you can attach the wires to power supply and signal outputs to data acquisition equipment (computer).

The typical power supply requirements of the u[sonic] sensors are 24 VDC with a typical current drain of 35 mA. The input range is 6...60 VDC or 12...42 VAC. The heater of the u[sonic] has to be supplied with 24 V AC/DC. In standard configuration the heating power is 240 W with a current drain of 10 A at 24 VDC. The signal output of the sensors is conform to the requirements of RS422 standard in talker mode. The line drivers are capable of transmitting data over cable lengths up to 1,220 meters (4,000 feet). This maximum distance will vary depending on the quality of the used cables. When the power supply of the sensor is switched on, after 2 seconds the sensor cyclically starts sending data protocols.

4.9.3 Safety regulations



Because the wind sensor often is mounted on exposed locations in dangerous heights the installation personnel has to pay attention to the relevant safety regulations for such works. During the electrical installation and termination works the external circuit-breaker must be switched off. It is not permitted to open those housings by unauthorized persons!

5 Maintenance

5.1 Regular maintenance and calibrations

The sensor u[sonic] is service reduced and designed for a very long lifetime. Recommended is a regular visual check regarding dirt of surface caused by the weather and if so, to clean up.



If reference measurements should be necessary stringently must be noted that a comparability of the measured values is given only if the measurements take place under same conditions. I.e. the reference equipment must be used very close to the sensor!

The sensor is a measuring instrument and thus apply user specific standards regarding period of recalibration. Recommendation: 2 years.

5.2 Visual inspections and cleaning

The use of the sensor under the respective environmental conditions requires certain steps. It is thus recommendable to clean the outside of the housing within specific intervals. The intervals are dependant on the environmental conditions and the degree of soiling. We recommend a regular sight check. In case you should be faced with any specific problems please contact the Lambrecht service under:

Tel: +49 (0)551 49580 or E-Mail: support@lambrecht.net

6 Transports

In case the sensor should be shipped or transported by you, it has to be packed securely to avoid mechanical impact or other damages.

7 Disposal

LAMBRECHT meteo GmbH is listed and registered at the Stiftung Elektro-Altgeräte Register ear under:

WEEE-Reg.-Nr. DE 45445814

In the category of monitoring and control instruments, device type: "Monitoring and control instruments for exclusively commercial use".

Within the EU



The device has to be disposed according to the European Directives 2002/96/EC and 2003/108/EC (Waste Electrical and Electronic Equipment). Do not dispose the old device in the household waste! For an environmentally friendly recycling and disposal of your old device, contact a certified disposal company for electronic waste.

Outside the EU

Please follow the regulations in your country regarding the appropriate disposal of waste electronic equipment.



8 Dimensional drawing

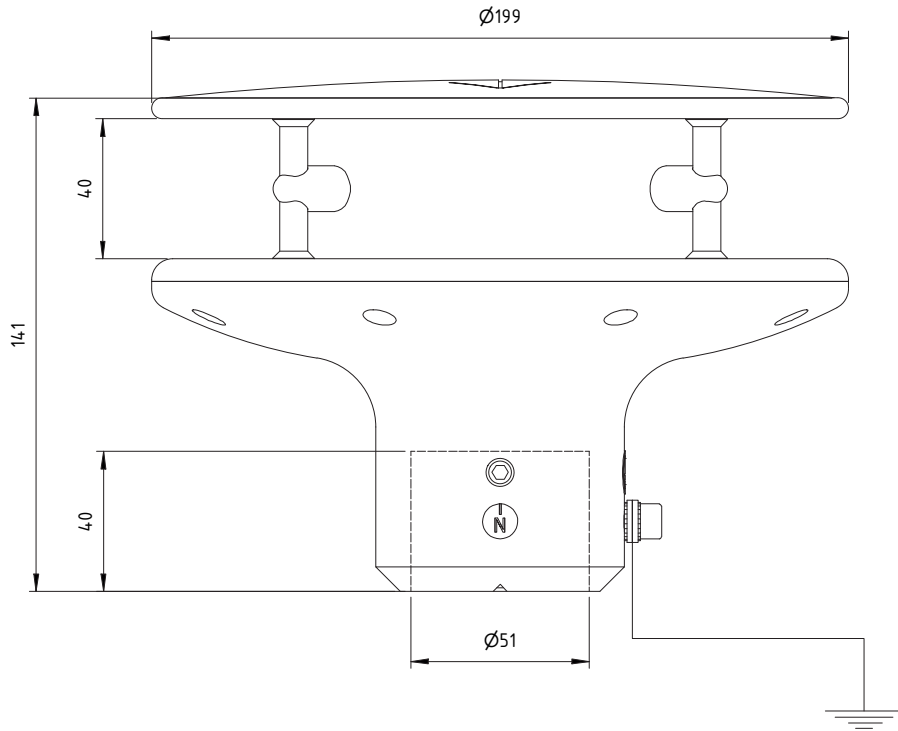

9 Connection diagram

Sensor-side plug (male),
M12, 4-pin, shielded

Cable-side socket (female),
M12, 4-pin, shielded

Cable color code

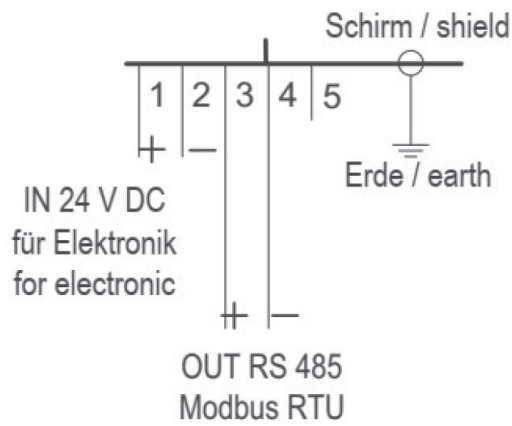
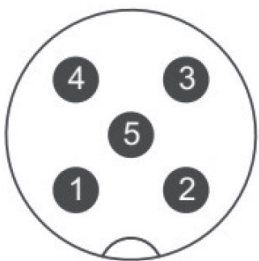

PIN	color	Farbe
1	br	br
2	wt	ws
3	bl	bl
4	bk	sw
5	N/A	N/A

10 Modbus protocol

Note: Modbus must be configured in default.

This manual covers the general Modbus specification common to all Modbus sensors from LAMBRECHT meteo. The manual allows easy operation of all LAMBRECHT meteo Modbus sensors. Some sensors of the Modbus family offer additional registers and functions, which are described in separate documents via the registers and functions described here. The registers and functions described in this manual are sufficient for general operation of Modbus sensors in a weather station or PLC.

10.1 General

The LAMBRECHT meteo Modbus sensors follow the specification of the Modbus organization: "MODBUS APPLICATION PROTOCOL SPECIFICATION V1.1b3" (see www.modbus.org).

10.2 Data encoding

MODBUS uses the "Big-Endian" format for addresses and data. This means that if a value is transmitted with a number format which is larger than a single byte, that the "most significant byte" is sent first.

Example Big-Endian:

Register size value 16 - bits

0x1234 is transmitted in the sequence: 0x12 0x34.

To obtain the real measuring value, divide the received register value by the divisor.

Values of -9999 indicate an internal sensor error.

10.3 Standard configuration - Default

Baud rate:	19200 Baud
Byte frame:	8E1 (1 start bit, 8 data bits, 1 parity bit (even parity), 1 stop bit)
RTU Sensor address:	9



DEFAULT ADDRESSES OF THE LAMBRECHT SENSORS

Address	Sensor
1	Wind speed
2	Wind direction
3	Precipitation rain[e]
4	THP
5	EOLOSIND; u[sonic]WS6
6	com[b]
7	PREOS
8	ARCO
9	u[sonic]
10	Pyranometer 2nd Class
11	Secondary standard Pyranometer
12	PT100 ot Modbus converter (temperature)
13	u[sonic]WS7

10.4 Available Modbus commands

The LAMBRECHT Modbus sensors support the following commands:

- “Read Holding Register” command: 0x03 (descriptive sensor data registers)
- “Read Input Register” command: 0x04 (measured values registers)
(every measured value is to be requested individually)
- “Write Multiple Register” command: 0x10 (Write to configuration registers)

10.5 Instantaneous values / real-time values (Input Registers)

The following measured values are provided by the LAMBRECHT meteo sensors.

Register address	Parameter name	Unit	Divisor	Quantity of registers	Access type
30001	Wind speed	m/s	10	1	Read only
30201	Wind direction	°	10	1	Read only

Example: Retrieving the wind speed

0D	04	75	31	00	01	7A	C5	0D	04	02	00	1F	E8	F9
----	----	----	----	----	----	----	----	----	----	----	----	----	----	----

LEN	Transmission	Source	Dest	Function	Func Desk	Checksum
6	Query =>	Master	Slave 13	Read Input Register (4)	Address=30001, Quantity of Register=1	OK:C57A

LEN	Transmission	Source	Dest	Function	Func Desk	Data	Checksum
5	Response <=	Slave 13	Master	Read Input Register (4)	Byte count=2	00 1F	OK:F9E8

10.6 Period data - Average, maximum and minimum (Input Registers)

Register	Parameter name	Unit	Divisor	Quantity of registers	Access type
30002	Wind speed average	m/s	10	1	Read only
30003	Wind speed maximum	m/s	10	1	Read only
30004	Wind speed minimum	m/s	10	1	Read only
30202	Wind direction average	°	10	1	Read only
30203	Wind direction maximum	°	10	1	Read only
30204	Wind direction minimum	°	10	1	Read only

The data are valid for the period between the current request and the previous request. The maximum range of a period is 1 hour. Recalling the average value of a minimum, maximum and average group will erase the appropriate registers.

Retrieve the values of a group in the sequence minimum, maximum, average.
Use command: 0x03

Example: Retrieve wind speed (min. max. avr.) and erase the register content

01	04	75	34	00	01	6A	08	01	04	02	00	00	B9	30	01
04	75	33	00	01	DB	C9	01	04	02	00	D6	38	AE	01	04
75	32	00	01	8A	09	01	04	02	00	14	B9	3F			

LEN 6	Transmission Query =>	Source Master	Dest Slave 1	Function Read Input Register (4)	Func Desk Address=30004, Quantity of Register=1	Checksum OK:86A
LEN 5	Transmission Response <=	Source Slave 1	Dest Master	Function Read Input Register (4)	Func Desk Byte count=2	Data 00 00 Checksum OK:30B9
LEN 6	Transmission Query =>	Source Master	Dest Slave 1	Function Read Input Register (4)	Func Desk Address=30003, Quantity of Register=1	Checksum OK:C9DB
LEN 5	Transmission Response <=	Source Slave 1	Dest Master	Function Read Input Register (4)	Func Desk Byte count=2	Data 00 D6 Checksum OK:AE38
LEN 6	Transmission Query =>	Source Master	Dest Slave 1	Function Read Input Register (4)	Func Desk Address=30002, Quantity of Register=1	Checksum OK:98A
LEN 5	Transmission Response <=	Source Slave 1	Dest Master	Function Read Input Register (4)	Func Desk Byte count=2	Data 00 14 Checksum OK:3FB9

10.7 Descriptive sensor parameter registers (Holding Registers)

Register	Parameter name	Quantity of registers	Remark	Access type
40050	Device identification number (15 characters)	8 (2 characters in each register)	The returned data are in form of a 16 byte null terminated string	Read only
40100	Serial number (11 characters)	6 (2 characters in each register)	The returned data are in form of a 12 byte null terminated string	Read only
40150	Firmware version (up to 25 characters)	13 (2 characters in each register)	The returned data are in form of a 26 byte null terminated string	Read only

Example: Retrieve the device identification number

(The identification number shown in the example is sensor-dependent. It is only used here for demonstration purposes).

0D	03	9C	72	00	08	CA	8B	0D	03	10	30	30	2E	31	36	□□□□□□□□□□□□□□
34	38	30	2E	30	30	31	31	33	30	00	E8	6B				00.16480.000130□□□□

LEN	Transmission	Source	Dest	Function	Func Desk	Checksum	
6	Query =>	Master	Slave 13	Read Holding Register (3)	Address=40050, Quantity of Register=8	OK:8BCA	
LEN	Transmission	Source	Dest	Function	Func Desk	Data	Checksum
19	Response <=	Slave 13	Master	Read Holding Register (3)	Byte count=16	30 30 2E 31 36 34 38 30 2E 30 30 31 31 33 30 00	OK:6BE8

10.8 Configuration registers (Holding Registers)

Register	Parameter name	Allowed values	Quantity of registers	Access type
40001	Modbus device address		1	Write only
40200	Baud rate	96 = 9600 192 = 19200 384 = 38400	1	Write only
40201	Parity	1 = even 0 = none	1	Write only

The device must be restarted after each change of a setting!

Example: Changing the RTU address from 4 to 1

05	10	9C	41	00	01	02	00	01	06	48	05	10	9C	41	00
01	7E	09													

LEN 9	Transmission Query =>	Source Master	Dest Slave 5	Function Write Multiple Register (16)	Func Desk Address=40001, Quantity=1	Byte count 2	Register values 00 01	Checksum OK:4806
LEN 6	Transmission Response <=	Source Slave 5	Dest Master	Function Write Multiple Register (16)	Func Desk Address=40001, Quantity=1	Checksum OK:097E		

10.9 Autoconfiguration

All Lambrecht Modbus sensors offer the experienced user the possibility to implement an auto-configuration in his Modbus master based on additional information stored in the sensor. The necessary information can be found in the document “Lambrecht_Modbus_Autoconfiguration”.

11 Technical data

Combined Ultrasonic Wind Sensor u[sonic] Modbus	
ID	00.16470.100130
Measuring principle	ultrasound
Measuring range	wind direction: 0...359.9° wind speed: 0...75 m/s
Survival wind speed	100 m/s
Accuracy	wind direction: < 2° (> 1 m/s) RMSE wind speed: 0.2 m/s RMSE (v < 10 m/s); 2 % RMSE (10 m/s < v < 65 m/s)
Resolution	wind direction: 0.1° wind speed: 0.1 m/
Response threshold	0.1 m/s (adjustable for wind direction)
Output	RS 485
Protocol	Modbus RTU
Internal measuring rate	50 Hz
Operating conditions	-40...+70 °C (with heating -50...+70 °C); 0...100 % r. h.
Supply voltage	without heating: 6...60 VDC; with heating: 24 VAC/DC ± 20 %
Current consumption	sensor: typically 50 mA at 24 VDC and deactivated analog output; heating: maximal 2,5 A at 24 VAC/DC
Heating data	60 W (factory configurable)
Dimensions	Ø 199 mm; height 149 mm
Housing	seawater resistant aluminum; IP 66; IP 67
Weight	approx. 2 kg
Standards	<ul style="list-style-type: none"> • VDE 0100 • Low voltage guide line: 72/23 EWG • EMC/EMI: DIN EN 60945 and DIN EN 61000-4-2, -3, -4, -5, -6, -11 • Protection class: DIN EN 60529
Accessories (please order separately)	
ID 32.14567.060010	Sensor cable; 15 m; 4-pole; M12 plug