



USER MANUAL

ARCO-Modbus

Wind Sensor



Contents

1	Features and benefits	3
2	Warranty	3
3	Disposal	3
4	What is the ARCO-Modbus?	4
5	Start-up	4
5.1	Installation conditions	4
5.2	Tools and installation material	5
5.3	Unpacking the sensor	5
5.4	Incoming goods inspection	5
5.5	Power supply	5
5.6	Mounting the cup rotor and wind vane	5
5.7	Installation work (short description)	6
5.8	Mounting the sensor	6
5.9	Alignment of wind vane	6
6	Power and signal connection	7
7	Safety regulations	7
8	Maintenance	8
8.1	Regular maintenance and calibration	8
8.2	Visual check and cleaning	8
9	Transport	8
10	Dimensional drawing	9
11	Connection diagram	10
12	Modbus data protocols	11
12.1	General	11
12.2	Data encoding	11
12.3	Standard configuration - Default	11
12.4	Available Modbus commands	12
12.5	Instantaneous values / Real-time values (Input register)	12
12.6	Period data - Average, maximum and minimum (Input register)	12
12.7	Descriptive sensor parameter registers (Holding register)	13
12.8	Configuration registers (Holding register)	14
13	Autoconfiguration	14
14	Technical data	15



1 Features and benefits

- Compact and extremely robust sensor for measuring wind direction and wind speed
- Frictionless measured value acquisition due to non-contact measuring principle
- Seawater-resistant surfaces for a long product life
- Increased watertightness through water traps integrated in the sensor neck
- Electronically controlled, integrated heating of the sensor heads
- Wind vane and 3-armed cup rotor changeable
- Quick and easy installation with pipe mounting and M12 plug connection

2 Warranty

Please note the loss of warranty and non-liability by unauthorized manipulation of the system. You need a written permission of the LAMBRECHT meteo GmbH for changes of system components. These activities must be operated by a qualified technician.

The warranty does not cover:

1. Mechanical damages caused by external impacts (e. g. icefall, rockfall, vandalism).
2. Impacts or damages caused by over-voltages or electromagnetic fields which are beyond the standards and specifications in the technical data.
3. Damages caused by improper handling, e. g. by wrong tools, incorrect installation, incorrect electrical installation (false polarity) etc.
4. Damages which are caused by using the device beyond the specified operation conditions.

3 Disposal

LAMBRECHT meteo GmbH is recorded and registered at the Stiftung Elektro-Altgeräte Register ear under:

WEEE reg. no. DE 45445814

In the monitoring and control instrument category, type of device: "Monitoring and control instruments for exclusively commercial use."

Within the EU



The device must be disposed of in accordance with European directives 2002/96/EC and 2003/108/EC (waste electrical and electronic devices). Waste devices must not be disposed of with household garbage! For environmentally friendly recycling and disposal of your waste device, please contact a certified disposal company for electronic waste.

Outside the EU

Please observe the regulations applicable to the proper disposal of waste electronic devices in each country.

4 What is the ARCO-Modbus?

The sensors of the ARCO series are very robust, compact and extremely reliable. When developing these sensors particular consideration has been given to the fulfillment of meteorological requirements. The system acquires the horizontal air flow and processes the measuring data to the meteorological parameters wind speed and wind direction. The sensors and further system components are mounted in a splash water resistant and dust-proof metal housing.

The measured data are output via a galvanically isolated RS485 interface via Modbus RTU after switching on the supply voltage. Due to their shock and vibration proof construction the sensors ARCO-Modbus are particularly qualified for use under severe environmental conditions. The housing and the measuring elements are made of seawater resistant aluminum alloys. The housing, the cup rotor and the wind vane are anodized. An electronically controlled sensor heating device allows for operation of the sensor over the wide range of -30...70 °C.

5 Start-up

Wind can be represented by a vector quantity. For a complete description of the wind it is necessary to specify its speed and direction. The two components are subject to spatial and temporal variations; thus, strictly speaking, the values are only valid for the site where the measuring instrument is installed. We therefore recommend selecting the place of installation very carefully.

5.1 Installation conditions

For professional wind measurements the location and height of the wind sensor are important for accurate, correct results and representative wind conditions. Ideally, the sensor should be installed 10 m above the ground on a mast. There should also be nothing affecting wind flow within a radius of 150 m around the sensor. This may be buildings, trees, tall towers, lifting cranes, moving vehicles, aircrafts, helicopters or other obstructions. In the case of mobile measurements on vehicles often the above mentioned conditions are not practicable. Then you have to find compromises.

Generally, wind measuring instruments should not measure the specific wind conditions of a limited area, but indicate the typical wind conditions of a wider area. The values measured at different places must be comparable. Thus, when installing the sensor you should make sure the place of installation is not under the lee of great obstacles. The distance between the obstacles and the sensor should be 10 times the height of the obstacles (this corresponds to the definition of an undisturbed terrain). If an undisturbed terrain of this kind does not exist, the sensor must be put up at a height of at least 5 m above the obstacle height.

If the sensor must be installed on a roof top, the place of installation must be in the middle of the roof to avoid predominant wind directions. If you want to measure both wind direction and wind speed, if possible, the sensors should be mounted at the same measuring point, with any mutual interference of the sensors being avoided. The sensor ARCO-Modbus meets this requirement.



The sensor must not be installed on, or close to, transmitting plants or antennas. A minimum distance of 2 m is to be kept for interference-free signal transfer.



5.2 Tools and installation material

There are no special tools or materials required for installation or maintenance. All work can be carried out with standard tools available in a regular workshop.

5.3 Unpacking the sensor

The sensor is packed in a separate box, carefully protected against mechanical influences, in order to avoid damage during transport. When securely installed, the sensor can withstand shock and vibration, which normally occurs on ships.

Please verify that the following parts and documents are enclosed:

- 1 sensor ARCO-Modbus
- 1 user manual

Accessories: (Dependant on order size, always separately packed)

5.4 Incoming goods inspection

Please thoroughly check the delivery with regard to completeness and eventual transport damages. In case of eventual claims please contact us in writing immediately.

5.5 Power supply

The sensor requires at the input connector a 24 volt nominal DC power source for operation. The sensor heating has a power consumption of 2.9W.

5.6 Mounting the cup rotor and wind vane

The drill holes on the cup rotor are arranged in such a way that it can only be mounted in a specific, unambiguous position. All screws have to be used and the cup rotor or the wind vane have to be fixed with them. This ensures the correct direction of rotation. The required Allen key is included in the scope of delivery.

The wind vane can only be mounted in a specific position. Use all two screws to attach the wind vane to the sensor head. This is the only way to ensure a correct measurement of the wind direction.

MOUNTING THE CUP ROTOR

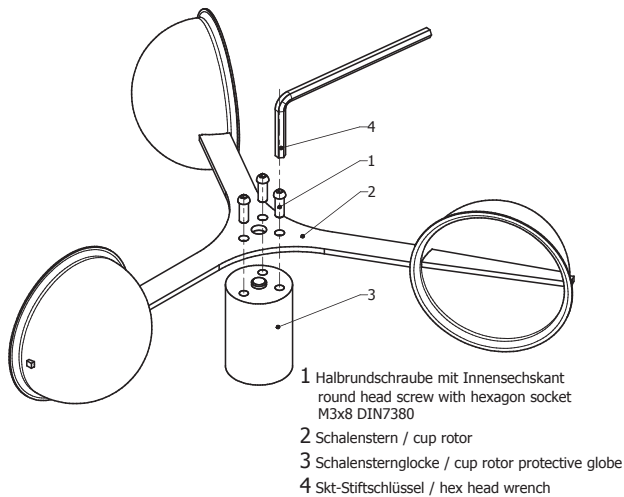

MOUNTING THE WIND VANE

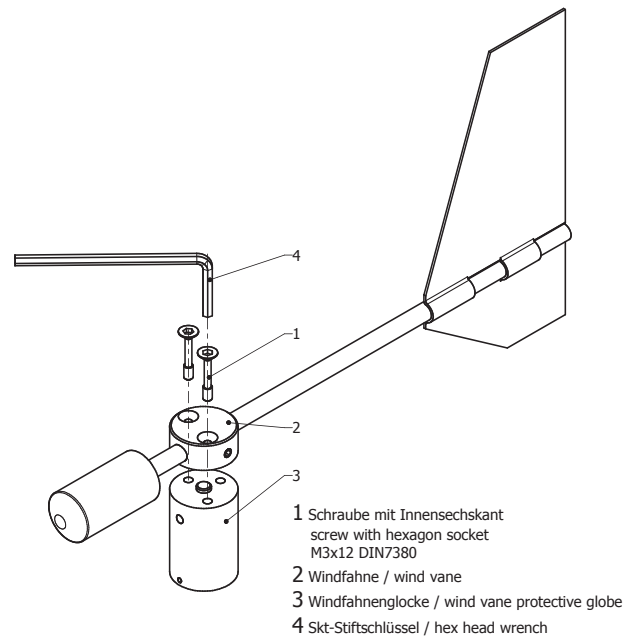

5.7 Installation work (short description)

The installation of the sensor involves 3 steps:

1. Mounting the cable on the sensor and if necessary drawing the cable through the mast.
2. Mounting the sensor on the mast, but before tightening the screws you must align the sensor to the north.
3. Attaching the cable to the power supply and the signal acquisition system.

5.8 Mounting the sensor

The sensor can be installed on a standard pipe with an outer diameter of 50 mm and an inner diameter of at least 40 mm. Before attaching the unit with the two 8 mm socket screws, the cable must be connected, by drawing it through the pipe and the sensor aligned to the north or in the forward driving direction. For this purpose the housing is marked accordingly (see drawing). Adjust the sensor to the north before tightening the screws.



Please make sure that the sensor is firmly attached to the mast!

5.9 Alignment of wind vane

For wind direction measurements the north mark on the sensor must be aligned with the geographical north direction. To adjust the wind sensor in a firm and correct manner into the north direction this item is equipped with an integrated mounting aid. Inside the inner bottom of the sensor a small bolt pointing to the north is integrated to be set into a corresponding slot of the mounting pipe (if available). Thus the sensor is safely attached. If needed you can screw or unscrew the pin by means of an Allen key.



You have to turn the marking on the wind vane so that it is exactly over the marking on the sensor shaft. Fix the position of the wind vane with, for example, a piece of adhesive tape. After alignment the adhesive tape has to be removed.

When you have fixed the wind vane you can locate the reference point by aiming at it over the axis. Now you must turn the sensor casing on the mounting tube until the tip of the wind vane points to the reference point in the north. To set up the sensor's north orientation select a landmark which is as far as possible up north with regard to the final position of the wind direction sensor. The reference point can be selected using a topographical map (1:25000). The exact position of the reference point is determined using an amplitude compass that can be adjusted horizontally on a stand.



The compass declination has to be considered!

A functional check at three points offset by 90° directions is recommended.



Follow all safety instructions while setting up the sensor on to a mast.

6 Power and signal connection

If the sensor is mounted in the correct manner and connected with the right cable (accessory), you can attach the wires for the power supply and signal outputs to the data acquisition equipment (computer). The ARCO-Modbus sensor requires a 4-pole M12 plug connector. The cable shield should be connected with both ends at the ground wire (PE).



To reduce the risk of inductive interference the sensor must be properly grounded (screening on both sides).

The external connection is carried out via a central connector which is located in the housing base. For further details about the electrical connection please see section "Electrical connection". The typical power supply of the sensors is 24 VDC with a current consumption of max. 920 mA (incl. heating). The input voltage range can be 20...28 VDC. The heating of the ARCO-Modbus has a heating power of 2.9 W.

Under most climatological conditions the heating prevents blocking of the moving sensor parts. Neither the cup rotor nor the wind vane are heated. In the case of icing or formation of ice on the moving sensor element the function is restricted for the period of icing. The output signal of the sensor conforms to the Modbus RTU to RS485 standard.

7 Safety regulations



Because the wind sensor is often mounted in exposed locations at dangerous heights the installation personnel have to pay attention to the relevant safety regulations. During the electrical installation work the external circuitbreaker must be switched off. It is not permitted for unauthorized persons to open the housing!

8 Maintenance

8.1 Regular maintenance and calibration

The sensors are very low-maintenance and designed for a very long lifetime. Regular visual checks are recommended, regarding dirt build-up on the surface caused by the weather. Whenever this is the case, we strongly recommend that you clean it. A regular visual and functional check of the wind sensor is recommended.



If reference measurements are necessary, it must be stringently noted that a comparison of the measured values is given only if the measurements take place under same conditions. I.e. the reference equipment must be used very close to the sensor!

The sensor is a measuring instrument and thus user specific standards apply regarding the period of recalibration.

Manufacturer's recommendation: 2 years.

For the long-term assurance of the function and accuracy of the proposed components, we are pleased to offer you our professional maintenance and calibration services.

8.2 Visual check and cleaning

The use of the sensor under the respective environmental conditions requires certain actions. It is thus recommendable to clean the outside of the housing and shelter within specific intervals. The intervals are dependent on the environmental conditions and the degree of soiling. We recommend a regular visual and functional check. In case you should be faced with any specific problems, which you are unable to solve, please contact the LAMBRECHT meteo service:

Tel: +49-(0)551-4958-0

E-mail: support@lambrecht.net

9 Transport

In case it is necessary for you to ship or transport the sensor, it must be carefully packed to prevent damages during transport.

10 Dimensional drawing

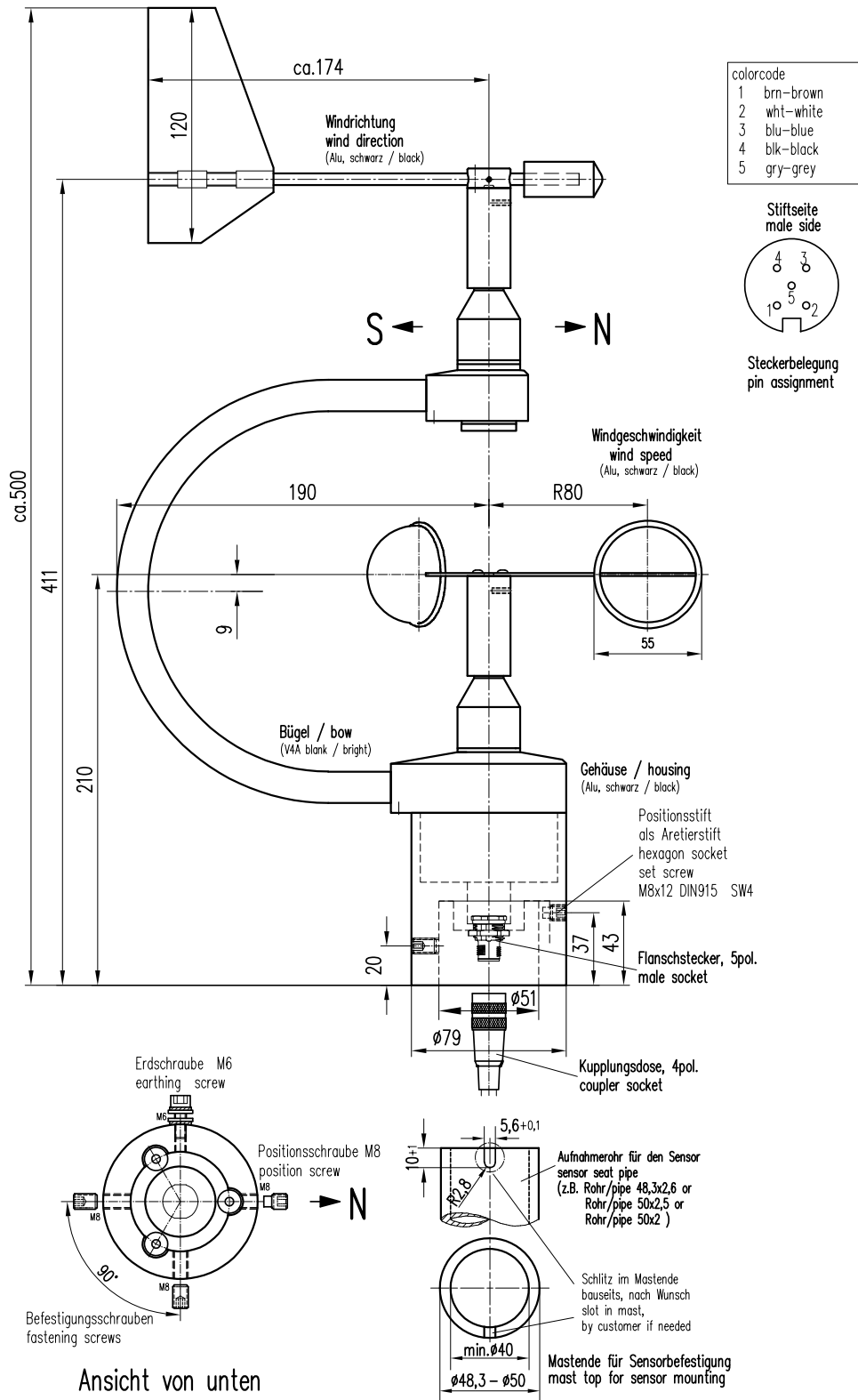

colorcode

1	brn-brown
2	wht-white
3	blu-blue
4	blk-black
5	gry-grey

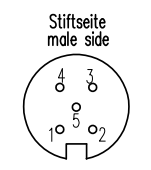

Steckerbelegung pin assignment

Gewicht : ca. __kg
 weigth : approx. __kgs
 Maßstab/scale : 1:3

11 Connection diagram

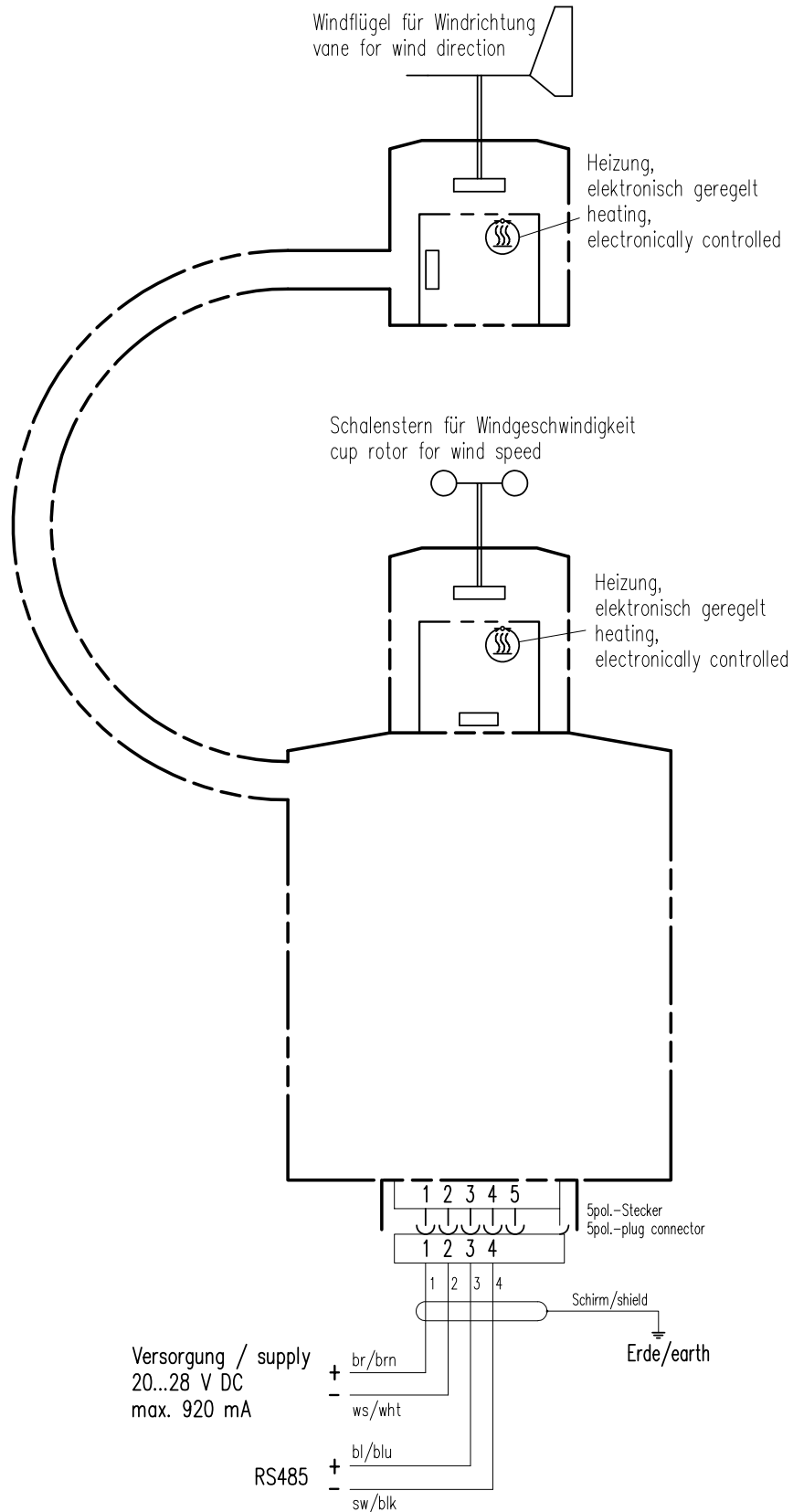

- PUR/PVC
colorcode
- 1 br - brn
 - 2 ws - wht
 - 3 bl - blu
 - 4 sw - blk
 - 5 gr - gry

12 Modbus data protocols

12.1 General

The Lambrecht meteo Modbus sensors follow the specification of the Modbus organization: “MODBUS APPLICATION PROTOCOL SPECIFICATION V1.1b3” (see www.modbus.org).

12.2 Data encoding

MODBUS uses the “Big-Endian” format for addresses and data. This means that if a value is transmitted with a number format which is larger than a single byte, that the “most significant byte” is sent first.

Example Big-Endian:

Register size value 16 - bits

0x1234 is transmitted in the sequence: 0x12 0x34.

To obtain the real measuring value, divide the received register value by the divisor.

Values of -9999 indicate an internal sensor error.

12.3 Standard configuration - Default

Baud rate: 19200 Baud

Byte frame: 8E1 (1 start bit, 8 data bits, 1 parity bit (even parity), 1 stop bit)

RTU Sensor address: 8

DEFAULT ADDRESSES OF THE LAMBRECHT SENSORS

Address	Sensor
1	Wind speed
2	Wind direction
3	Precipitation rain[e]
4	THP
5	EOLOS IND · u[sonic]WS6
6	com[b]
7	PREOS
8	ARCO
9	u[sonic]
10	Pyranometer 2nd Class
11	Secondary standard Pyranometer
12	PT100 to Modbus converter (temperature)
13	u[sonic]WS7

12.4 Available Modbus commands

The LAMBRECHT Modbus sensors support the following commands:

- “Read Holding Register” command: 0x03 (descriptive sensor data registers)
- “Read Input Register” command: 0x04 measured value register (each value must be requested individually)
- “Write Multiple Register” command: 0x10 (write to configuration registers)

12.5 Instantaneous values / Real-time values (Input register)

The following measured values are provided:

Register address	Parameter name	Unit	Divisor	Quantity of registers	Access type
30001	Wind speed	m/s	10	1	Read only
30201	Wind direction	°	10	1	Read only
30401	Air temperature	°C	10	1	Read only
30601	Relative humidity	% r. F.	10	1	Read only
30701	Dew point	°C	10	1	Read only
30801	Air pressure	hPa	10	1	Read only

Example: Retrieve wind speed

0D	04	75	31	00	01	7A	C5	0D	04	02	00	1F	E8	F9
LEN 6	Transmission Query =>	Source Master	Dest Slave 13	Function Read Input Register (4)		Func Desk Address=30001, Quantity of Register=1		Checksum OK:C57A						
LEN 5	Transmission Response <=	Source Slave 13	Dest Master	Function Read Input Register (4)		Func Desk Byte count=2		Data 00 1F	Checksum OK:F9E8					

12.6 Period data - Average, maximum and minimum (Input register)

Register	Parameter name	Unit	Divisor	Quantity of registers	Access type
30002	Wind speed average	m/s	10	1	Read only
30003	Wind speed maximum	m/s	10	1	Read only
30004	Wind speed minimum	m/s	10	1	Read only
30202	Wind direction average	°	10	1	Read only
30203	Wind direction maximum	°	10	1	Read only
30204	Wind direction minimum	°	10	1	Read only
30402	Air temperature average	°C	10	1	Read only
30403	Air temperature maximum	°C	10	1	Read only
30404	Air temperature minimum	°C	10	1	Read only
30602	Relative humidity average	% r. F.	10	1	Read only
30603	Relative humidity maximum	% r. F.	10	1	Read only
30604	Relative humidity minimum	% r. F.	10	1	Read only
30702	Dew point average	°C	10	1	Read only
30703	Dew point maximum	°C	10	1	Read only
30704	Dew point minimum	°C	10	1	Read only
30802	Air pressure average	hPa	10	1	Read only
30803	Air pressure maximum	hPa	10	1	Read only
30804	Air pressure minimum	hPa	10	1	Read only



The data are valid for the period between the current request and the previous request. The maximum range of a period is 1 hour. Recalling the average value of a minimum, maximum and average group will erase the appropriate registers. Retrieve the values of a group in the sequence minimum, maximum, average.

Use command: 0x03

Example: Retrieve wind speed (min. max. avr.) and erase the register content

01	04	75	34	00	01	6A	08	01	04	02	00	00	B9	30	01
04	75	33	00	01	DB	C9	01	04	02	00	D6	38	AE	01	04
75	32	00	01	8A	09	01	04	02	00	14	B9	3F			

LEN 6	Transmission Query =>	Source Master	Dest Slave 1	Function Read Input Register (4)	Func Desk Address=30004, Quantity of Register=1	Checksum OK:86A
LEN 5	Transmission Response <=	Source Slave 1	Dest Master	Function Read Input Register (4)	Func Desk Byte count=2	Data 00 00 Checksum OK:30B9
LEN 6	Transmission Query =>	Source Master	Dest Slave 1	Function Read Input Register (4)	Func Desk Address=30003, Quantity of Register=1	Checksum OK:C9DB
LEN 5	Transmission Response <=	Source Slave 1	Dest Master	Function Read Input Register (4)	Func Desk Byte count=2	Data 00 D6 Checksum OK:AE38
LEN 6	Transmission Query =>	Source Master	Dest Slave 1	Function Read Input Register (4)	Func Desk Address=30002, Quantity of Register=1	Checksum OK:98A
LEN 5	Transmission Response <=	Source Slave 1	Dest Master	Function Read Input Register (4)	Func Desk Byte count=2	Data 00 14 Checksum OK:3FB9

12.7 Descriptive sensor parameter registers (Holding register)

Register	Parameter name	Quantity of registers	Remark	Access type
40050	Device identification number (15 characters)	8 (2 characters in each register)	The returned data are in form of a 16 byte null terminated string	Read only
40100	Serial number (11 characters)	6 (2 characters in each register)	The returned data are in form of a 12 byte null terminated string	Read only
40150	Firmware version (up to 25 characters)	13 (2 characters in each register)	The returned data are in form of a 26 byte null terminated string	Read only

Example: Retrieve the device identification number
 (The identification number shown in the example is sensor-dependent. It is only used here for demonstration purposes).

0D	03	9C	72	00	08	CA	8B	0D	03	10	30	30	2E	31	36	□□□□□□□□□□□□□□
34	38	30	2E	30	30	31	31	33	30	00	E8	6B				00.16480.000130□□□□

LEN	Transmission	Source	Dest	Function	Func Desk	Checksum
6	Query =>	Master	Slave 13	Read Holding Register (3)	Address=40050, Quantity of Register=8	OK:8BCA

LEN	Transmission	Source	Dest	Function	Func Desk	Data	Checksum
19	Response <=	Slave 13	Master	Read Holding Register (3)	Byte count=16	30 30 2E 31 36 34 38 30 2E 30 30 31 31 33 30 00	OK:6BE8

12.8 Configuration registers (Holding register)

Register	Parameter name	Allowed values	Quantity of registers	Access type
40001	Modbus device address		1	Write only
40200	Baud rate	96 = 9600 192 = 19200 384 = 38400	1	Write only
40201	Parity	1 = even 0 = none	1	Write only

The device must be restarted after each change of a setting!

Example: Change the RTU address from 4 to 1

05	10	9C	41	00	01	02	00	01	06	48	05	10	9C	41	00
01	7E	09													

LEN	Transmission	Source	Dest	Function	Func Desk	Byte count	Register values	Checksum
9	Query =>	Master	Slave 5	Write Multiple Register (16)	Address=40001, Quantity=1	2	00 01	OK:4806

LEN	Transmission	Source	Dest	Function	Func Desk	Checksum
6	Response <=	Slave 5	Master	Write Multiple Register (16)	Address=40001, Quantity=1	OK:097E

13 Autoconfiguration

All Lambrecht Modbus sensors offer the experienced user the possibility to implement an auto-configuration in his Modbus master based on additional information stored in the sensor. The necessary information can be found in the document “Lambrecht_Modbus_Autoconfiguration”.

14 Technical data

ARCO-Modbus	
ID	00.14581.030430
Range of application	Temperature : -40...+70 °C heated *; wind speed: 0...80 m/s; rel. humidity: 0...100% r. h.
Interface	RS485
Protocol	Modbus RTU
Supply voltage	sensor 20...28 VDC/ max. 920 mA at 24 VDC incl. heating 24 VDC/ 2.9 W
Housing	seawater-resistant aluminum; specially coated; IP 65 in vertical operating position
Dimensions	see dimensional drawing
Weight	approx. 1,7 kg
Standards	<ul style="list-style-type: none"> • EMC/EMI: EN 60945 • Low voltage guideline 73/23/EWG and VDE 0100 • WMO No. 8 • VDI 3786 Part 2 • NMEA 0183

PARAMETER WIND DIRECTION	
Measuring range	0...360°
Accuracy	±1%
Resolution	<1°
Starting value	0.3 m/s
Damping ratio	0.5...0,6

PARAMETER WIND SPEED	
Measuring range	0.3...75 m/s
Accuracy	± 2 % FS at 0.3...60 m/s
Resolution	< 0.1m/s
Starting value	0.3 m/s
Delay distance	4 m

ACCESSORIES (please order separately)	
ID 32.14567.060010	Sensor cable, 15 m, 4-pole M12 plug (different lengths possible)

HEATING STATUS (specified when ordering)	
ID 97.14581.000000	The corresponding NMEA protocol is factory-activated if required. Please specify ID for protocol activation when ordering.

*) Remark: In the case of icing and formation of ice at the movable sensor measuring element, the function is restricted for the period of icing.

Copyright © 2024 LAMBRECHT meteo GmbH. All rights reserved.
Information in this document subject to change without notice.
Photo copyright: © ustas - Adobe stock

14581_ARCO-Modbus_b-de.indd 23.24

LAMBRECHT meteo GmbH
Friedländer Weg 65-67
37085 Göttingen
Germany

Tel +49-(0)551-4958-0
Fax +49-(0)551-4958-312
E-Mail info@lambrecht.net
Internet www.lambrecht.net

