



USER MANUAL

16103.5

Second Class Pyranometer



Warning statements



Putting more than 30 Volt across the sensor wiring of the main power supply can lead to permanent damage to the sensor.



For proper instrument grounding: use 16103.5 with its original factory-made cable. See chapter on grounding and use of the shield.



Using the same Modbus address for more than one device will lead to irregular behavior of the entire network.



Your data request may need an offset of +1 for each 16103.5 register number, depending on processing by the network master. Consult the manual of the device acting as the local master.

This system is designed according to the state-of-the-art accepted safety regulations. However, please note the following rules:

1. Before putting it into operation please read all respective manuals!
2. Please observe all internal and state-specific guidelines and/or rules for the prevention of accidents. If necessary, ask your responsible safety representative.
3. Use the system only as described in the manual.
4. Always have the manual at hand at the installation site.
5. Use the system within the specified operating condition. Eliminate influences, which might impair safety.

Please note the loss that unauthorised manipulation of the system shall result in the loss of warranty and non-liability. Changes to system components require express written permission from LAMBRECHT meteo GmbH. These activities must be performed by a qualified technician.

The warranty does not cover:

1. Mechanical damage caused by external impacts (e.g. icefall, rockfall, vandalism).
2. Impacts or damage caused by over-voltage or electromagnetic fields which are beyond the standards and specifications of the device.
3. Damage caused by improper handling, e.g. by using the wrong tools, incorrect installation, incorrect electrical installation (incorrect polarity) etc.
4. Damage caused by using the device outside the specified operation conditions.

Modbus® is a registered trademark of Schneider Electric, licensed to the Modbus Organization, Inc.

Contents

Warning statements	2
Contents	3
Introduction	4
1 Ordering and checking at delivery	6
1.1 Ordering 16103.5	6
1.2 Included items	6
1.3 Quick instrument check	6
2 Instrument principle and theory	7
3 Specifications of 16103.5 series	8
3.1 Specifications	8
3.2 Dimensions of 16103.5	11
4 Installation of 16103.5	12
4.1 Site selection and installation	12
4.2 Mounting and levelling 16103.5	13
4.3 Installing 16103.5	14
4.4 Installing 16103.5 with its ball levelling and tube mount	14
4.5 Placing and removing 16103.5's ball levelling shim	15
4.6 Electrical connection of active 16103.5 series: wiring diagram	16
4.7 Electrical connection of passive 16103.5: wiring diagram	17
4.8 Grounding and use of the shield	17
4.9 Using 00.16103.501040's analogue 4 to 20 mA output	17
4.10 Using 00.16103.501060's analogue 0 to 1 V output	19
4.11 Connecting 00.16103.501060 to an RS-485 network	20
5 Modbus RTU Communication with 00.16103.501060	21
5.1 Modbus-protocol	21
5.2 Data encoding	21
5.3 Device-address	21
5.4 Standard configuration - default	21
5.5 Modbus command set	22
5.6 Measured value and parameter register	22
5.7 Sensor parameters / configuration-parameters	23
5.8 Network communication: getting started	24
5.9 Adapting the Modbus address and communication settings	24
6 Maintenance and trouble shooting	25
6.1 Recommended maintenance and quality assurance	25
6.2 Trouble shooting	26
7 Appendices	28
7.1 Appendix on cable extension / replacement	28
7.2 LAMBRECHT meteo – Auto-configuration	28
7.3 EU declaration of conformity	31

Introduction

16103.5 series is the most affordable range of pyranometers meeting ISO 9060 second class requirements. They are ideal for general solar radiation measurements in (agro-) meteorological networks and PV monitoring systems. The pyranometers are easy to mount and install. Various outputs are available, both digital and analogue, for ease of integration.

- Version 00.16103.501060:
digital sensor with Modbus over RS-485 and analogue 0-1 V output
- Version 00.16103.501040:
digital sensor with Modbus over TTL and analogue 4-20 mA output
- Version 00.16103.501000: analogue sensor with analogue millivolt output

Benefits of the 16103.5 series:

- Industry standard digital outputs or analogue millivolt output:
easy implementation and servicing
- Easy mounting and levelling
- Pricing: second class pyranometers finally affordable for large networks

Using the analogue version 00.16103.501000 is easy: the pyranometer can be connected directly to commonly used data logging systems. The irradiance in W/m^2 is calculated by dividing the signal output, a small voltage, by the sensitivity. This sensitivity is provided with 00.16103.501000 on its calibration certificate.

The central equation governing 00.16103.501000 is: $E = U/S$

U: Voltage output in V
S: Sensitivity in $V/(W/m^2)$
E: Solar irradiance in W/m^2



Figure 0.1 16103.5 second class pyranometer seen from above

Optionally the sensor has a unique ball levelling mechanism and / or tube mount, for easy installation.



Figure 0.2 On the left 16103.5 second class pyranometer with bubble level and M12-A cable connector in its standard configuration; on the right 16103.5 with optional ball levelling 32.14627.006000, for easy mounting and levelling on the LAMBRECHT meteo traverse system 14627 and mast tube adapter 32.14567.006000.

Suggested use for 16103.5:

- general solar radiation measurements
- (agro-)meteorological networks
- PV power plant monitoring

The recommended calibration interval of pyranometers is 2 years. Ask LAMBRECHT meteo for information on ISO and ASTM standardized procedures for field calibration.

The ASTM E2848 “Standard Test Method for Reporting Photovoltaic Non-Concentrator System Performance” (issued end 2011) confirms that a pyranometer is the preferred instrument for PV system performance monitoring. 16103.5 pyranometer complies with the requirements of this standard.

1 Ordering and checking at delivery

1.1 Ordering 16103.5

There are three standard configurations for model 16103.5:

- Version 00.16103.501060:
digital sensor with Modbus over RS-485 and analogue 0-1 V output
- Version 00.16103.501040:
digital sensor with Modbus over TTL and analogue 4–20 mA output
- Version 00.16103.501000: analogue sensor with analogue millivolt output

Common options / accessories are:

- cable 12m, 5-pin, M12 plug connector Id-No. 32.05005.001500*
- cable 5m, M12 plug connector Id-No. 32.14567.060030
- cable 12m, M12 plug connector Id-No. 32.14567.060000
- cable 15m, M12 plug connector Id-No. 32.14567.060010
- cable 20m, M12 plug connector Id-No. 32.14567.060040
- ball levelling set Id-No. 32.14627.006000

*) *The 5-pin cable is required for the versions with the 0-1V output or the mV output.*

Suitable data loggers are:

- met[LOG] Id-No. 00.95800.010000
- Ser[LOG] Id-No. 00.95770.000000

1.2 Included items

Arriving at the customer, the delivery should include:

- pyranometer 16103.5
- cable of the length as ordered
- product certificate matching the instrument serial number

1.3 Quick instrument check

1. At power-up the signal may have a temporary output level different from zero; an offset. Let this offset settle down.
2. Check if the sensor reacts to light: expose the sensor to a strong light source, for instance a 100 W light bulb at 0.1 m distance. The signal should read $> 100 \text{ W/m}^2$ now. Darken the sensor either by putting something over it or switching off the light. The instrument irradiance output should go down and within one minute approach 0 W/m^2 .
3. Inspect the bubble level.
4. Inspect the instrument for any damage.
5. Check the instrument serial number as indicated by the software against the label on the instrument and against the certificates provided with the instrument.

2 Instrument principle and theory

The scientific name of 16103.5 is pyranometer. A pyranometer measures the solar radiation received by a plane surface from a 180° field of view angle. This quantity, expressed in W/m^2 , is called “hemispherical” solar radiation.

The solar radiation spectrum extends roughly from 285 to 3000×10^{-9} m. By definition a pyranometer should cover that spectral range with a spectral selectivity that is as “flat” as possible.

16103.5 employs a thermopile sensor with black coated surface, one dome and an anodized aluminum body with visible bubble level. It has a variety of industry standard outputs, both digital and analogue.

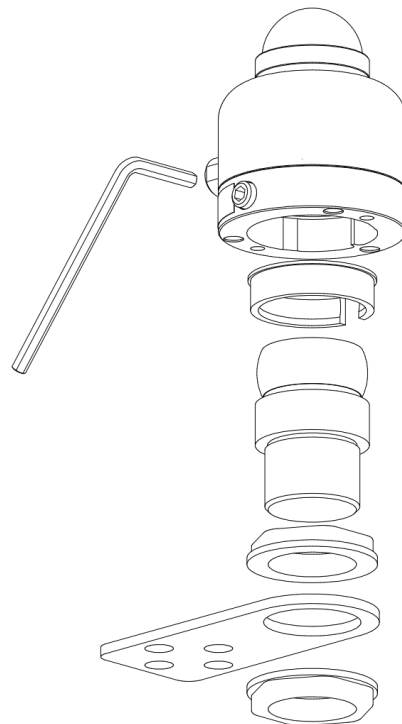

Figure 2.1 Overview of 16103.5 in exploded view with ball level set and traverse

Version 00.16103.501060 offers irradiance in W/m^2 as a digital output and as a 0-1 V output. It must be used in combination with suitable power supply and a data acquisition system which uses the Modbus communication protocol over RS-485 or one that is capable of handling a 0-1 V signal.

Version 00.16103.501040 offers irradiance in W/m^2 as a 4-20 mA output. It must be used in combination with suitable power supply and a data acquisition system which is capable of handling a 4-20 mA current loop signal.

Version 00.16103.501000 offers irradiance in W/m^2 as an analogue millivolt output. It is a passive sensor and does not need a power supply. It can be connected directly to commonly used data logging systems. The irradiance in W/m^2 is calculated by dividing the 00.16103.501000 output, a small voltage, by the sensitivity. This sensitivity is e.g. provided on its calibration certificate.

The central equation governing 00.16103.501000 is:

$$E = U/S$$

U: Voltage output in V

S: Sensitivity in $V/(W/m^2)$

E: Solar irradiance in W/m^2

3 Specifications of 16103.5 series

3.1 Specifications

16103.5 measures the solar radiation received by a plane surface from a 180° field of view angle. This quantity, expressed in W/m², is called “hemispherical” solar radiation. The instrument is classified according to ISO 9060 and should be used in accordance with the recommended practices of ISO, IEC, WMO and ASTM.

Table 3.1.1 Specifications of 16103.5 series

16103.5 MEASUREMENT SPECIFICATIONS: LIST OF CLASSIFICATION CRITERIA OF ISO 9060	
ISO classification (ISO 9060: 1990)	second class pyranometer
WMO performance level (WMO-No. 8, seventh edition 2008)	moderate quality pyranometer
Response time (95 %)	18 s
Zero offset a (response to 200 W/m ² net thermal radiation)	< 15 W/m ² unventilated
Zero offset b (response to 5 K/h change in ambient temperature)	< ± 4 W/m ²
Non-stability	< ± 1 % change per year
Non-linearity	< ± 1 % (100 to 1000 W/m ²)
Directional response	< ± 25 W/m ²
Spectral selectivity	< ± 5 % (0.35 to 1.5 x 10 ⁻⁶ m)
Temperature response	< ± 3 % (-10 to +40 °C)
Tilt response	< ± 2 % (0 to 90 ° at 1000 W/m ²)
Measurand	hemispherical solar radiation
Measurand in SI radiometry units	irradiance in W/m ²
Field of view angle	180 °
Measurement range	0 to 2000 W/m ²
Rated operating temperature range	-40 to +80 °C
Spectral range (20 % transmission points)	285 to 3000 x 10 ⁻⁹ m

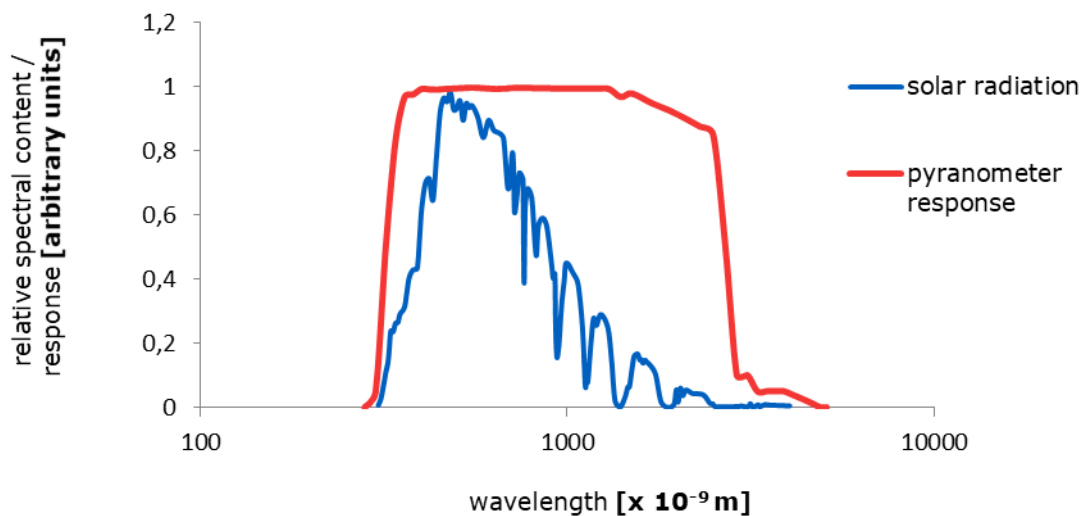

Figure 3.1.1 Spectral response of the pyranometer compared to the solar spectrum. The pyranometer only cuts off a negligible part of the total solar spectrum.

Standard governing use of the instrument	ISO/TR 9901:1990 Solar energy -- Field pyranometers -- Recommended practice for use ASTM G183 - 05 Standard Practice for Field Use of Pyranometers, Pyrhemometers and UV Radiometers
--	---

ADDITIONAL SPECIFICATIONS

Connector type	M12-A, 5-pole, IP67
Levelling accuracy	< 0.6 ° bubble entirely in ring
IP protection class	IP67
Net weight including 3 m cable	0.30 kg

00.16103.501060: DIGITAL

Digital output	irradiance in W/m ²
Irradiance resolution	0.2 W/m ²
Output definition	running average over 4 last measurements, measurement interval 0.1 s, refreshed every 0.1 s
Recommended data request interval	1 s, storing 60 s averages
Rated operating voltage range	5 to 30 VDC
Power consumption	< 75 x 10 ⁻³ W at 12 VDC
Communication protocol	Modbus over 2-wire RS-485, half duplex
Transmission mode	Modbus RTU

00.16103.501060: ANALOGUE 0 TO 1 V

Output definition	running average over 4 last measurements, measurement interval 0.1 s, refreshed every 0.1 s
Recommended data request interval	1 s, storing 60 s averages
0 to 1 V output	irradiance in W/m ²
Transmitted range	0 to 1600 W/m ²
Irradiance resolution	0.2 W/m ²
Output signal	0 to 1 V
Standard setting (see options)	0 V at 0 W/m ² and 1 V at 1600 W/m ²
Rated operating voltage range	5 to 30 VDC
Power consumption	< 75 x 10 ⁻³ W at 12 VDC

00.16103.501040: ANALOGUE 4 TO 20 mA

4 to 20 mA output	irradiance in W/m ²
Output definition	running average over 4 last measurements, measurement interval 0.1 s, refreshed every 0.1 s
Recommended data request interval	1 s, storing 60 s averages
Transmitted range	0 to 1600 W/m ²
Irradiance resolution	0.2 W/m ²
Output signal	4 to 20 x 10 ⁻³ A
Standard setting (see options)	4 x 10 ⁻³ A at 0 W/m ² and 20 x 10 ⁻³ A at 1600 W/m ²
Principle of 4 to 20 mA output	2-wire current loop
Rated operating voltage range	5 to 30 VDC
Power consumption	< 240 x 10 ⁻³ W at 12 VDC

00.16103.501000: ANALOGUE mV

Millivolt (mV) output	irradiance in W/m ²
Sensitivity range	7 to 30 x 10 ⁻⁶ V/(W/m ²)
Sensitivity (nominal)	10 x 10 ⁻⁶ V/(W/m ²)
Expected voltage output	application under natural solar radiation: -0.1 to +50 x 10 ⁻³ V
Measurement function / required programming	E = U/S U: Voltage output in V S: Sensitivity in V/(W/m ²) E: Solar irradiance in W/m ²
Irradiance resolution	depends on readout equipment; 7 x 10 ⁻⁶ V datalogger resolution is sufficient for 1 W/m ² resolution in irradiance
Required readout	1 differential voltage channel or 1 single ended voltage channel, input resistance > 10 ⁶ Ω
Sensor resistance range	40 to 80 Ω

HEATING

Heater	no heating
--------	------------

CALIBRATION

Calibration traceability	to WRR
Calibration hierarchy	from WRR through ISO 9846 and ISO 9847, applying a correction to reference conditions
Calibration method	indoor calibration according to ISO 9847, Type IIc
Calibration uncertainty	< 1.8 % (k = 2)*
Recommended recalibration interval	2 years
Reference conditions	20 °C, normal incidence solar radiation, horizontal mounting, irradiance level 1000 W/m ²
Validity of calibration	Based on experience the instrument sensitivity will not change during storage. During use under exposure to solar radiation the instrument "non-stability" specification is applicable.

* New calibration procedures were developed in close cooperation with PMOD World Radiation Center in Davos, Switzerland. The latest calibration method results in an uncertainty of the sensitivity of less than 1.8 %, compared to typical uncertainties of higher than 3.5 % for this pyranometer class.

MEASUREMENT ACCURACY AND RESOLUTION

Uncertainty of the measurement	statements about the overall measurement uncertainty can only be made on an individual basis. see the chapter on uncertainty evaluation
WMO estimate on achievable accuracy for daily sums (see appendix for a definition of the measurement conditions)	10 %
WMO estimate on achievable accuracy for hourly sums (see appendix for a definition of the measurement conditions)	20 %

3.2 Dimensions of 16103.5

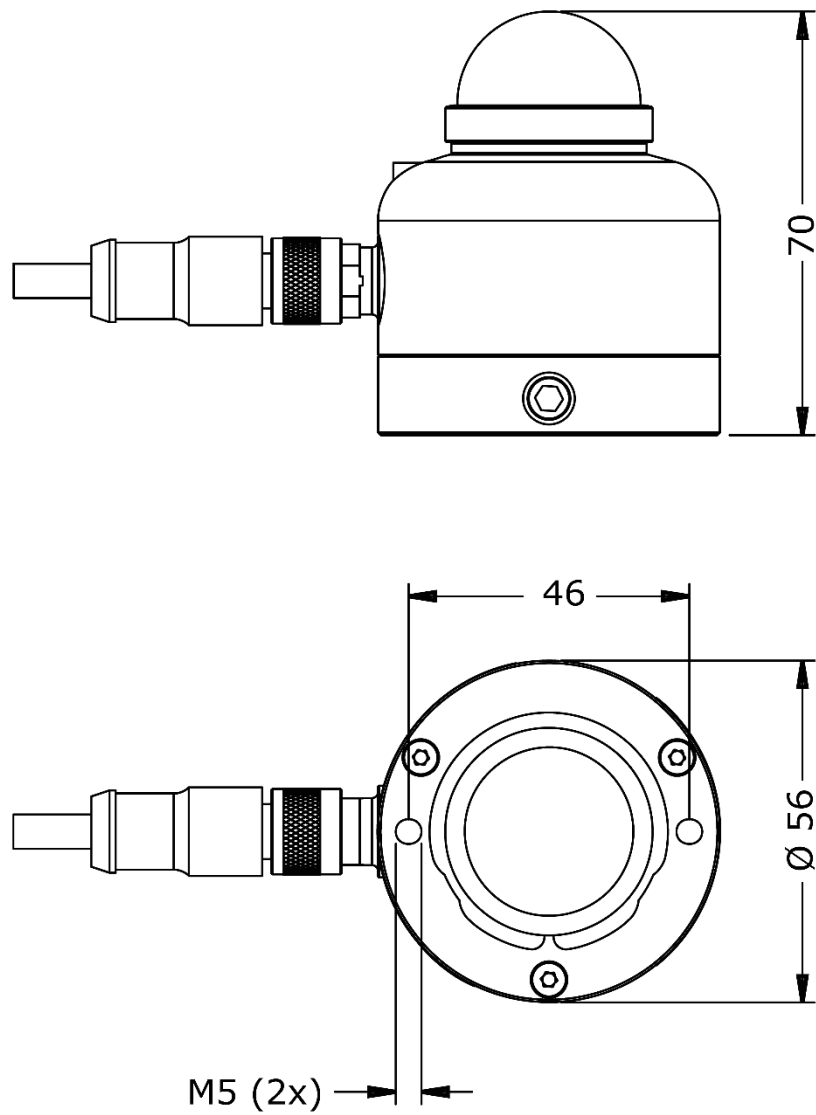

Figure 3.2.1 Dimensions of 16103.5 in $\times 10^{-3}$ m.

4 Installation of 16103.5

4.1 Site selection and installation

Table 4.1.1 Recommendations for installation of pyranometers

Location	The situation that shadows are cast on the instruments is usually not desirable. The horizon should be as free from obstacles as possible. Ideally there should be no objects between the course of the sun and the instrument.
Mechanical mounting / thermal insulation	Preferably use the ball levelling mount to mount 16103.5 to a (non-)horizontal surface. A pyranometer is sensitive to thermal shocks. Do not mount the instrument on objects that become very hot (black coated metal plates).
Instrument mounting	2 x M5 bolt at 46 mm centre-to-centre distance on north-south axis, connection through the sensor bottom in 16103.5's standard configuration. With ball levelling option: PG21 thread for mounting in 29mm-Ø bore hole
Performing a representative measurement	The pyranometer measures solar radiation in the plane of the sensor. This may require installation in a tilted or inverted position. The black sensor surface (sensor bottom plate) should be mounted parallel to the plane of interest. In case a pyranometer is not mounted horizontally or in case the horizon is obstructed, the representativeness of the location becomes an important element of the measurement. See the chapter on uncertainty evaluation.
Levelling	In case of horizontal mounting use the bubble level and optionally the ball levelling mount. The bubble level is visible and can be inspected at all times.
Instrument orientation	By convention with the cable exit pointing to the nearest pole (so the cable exit should point north in the northern hemisphere, south in the southern hemisphere).
Installation height	In case of inverted installation, WMO recommends a distance of 1.5 m between soil surface and sensor (reducing the effect of shadows and in order to obtain good spatial averaging).

4.2 Mounting and levelling 16103.5

In its standard configuration 16103.5 is equipped with a visible bubble level and two mounting holes. For easy mounting and levelling on a (non-)horizontal surface, 16103.5's optional ball levelling is recommended. Ball levelling offers:

- easy levelling
- easy cable orientation
- easy instrument exchange
- easy mounting (mounting bolts and nuts included)

When installing 16103.5, ball levelling allows 16103.5 to rotate 360 ° and to tilt up to 10 °. This allows compensation for up to a ten-degree angle when installing on a non-horizontal surface. A 4 mm hex key (un)locks the ball levelling mechanism.



Figure 4.2.1 From left to right: 16103.5 in its standard configuration; with optional ball levelling for easy mounting and levelling on a (non-)horizontal surface; with optional ball levelling and tube mount for easy installation on a 25 to 40 mm diameter tube. Mounting bolts are included with the ball levelling and / or tube mount.

4.3 Installing 16103.5

16103.5 without ball levelling and tube mounting options can be mounted using two M5 bolts (not included). For the required bolt lengths, 5 to 7 mm should be added to the thickness of the user's mounting platform.

4.4 Installing 16103.5 with its ball levelling

Two PG21 nuts are included with 16103.5's ball levelling option. These are to be used to mount 16103.5 with its ball levelling to a 29mm Ø-bore hole.

Table 4.4.1 Specifications of tools for 16103.5

CONFIGURATION	TOOLS
tooling required for mounting 16103.5 without ball levelling	two M5 bolts applicable screwdriver
tooling required for mounting 16103.5 with ball levelling	hex key 4 mm wrench size 8 mm for M5 nuts

The unique ball head mechanism of 16103.5's ball levelling mount is used to level the pyranometer.

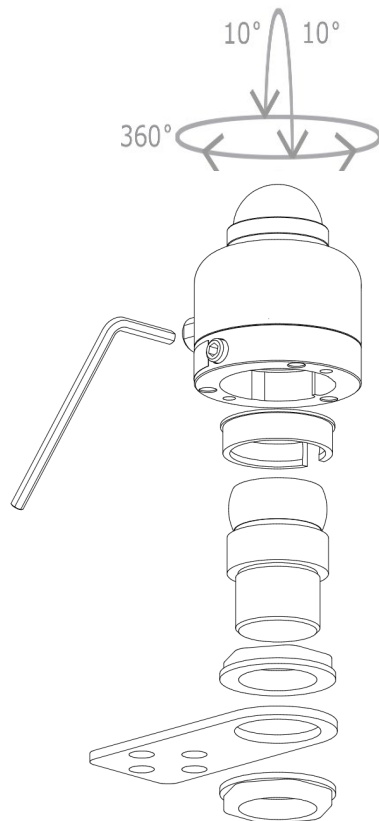

Figure 4.4.1 How to place 16103.5 on the ball levelling mounting set

To install 16103.5 to ball levelling mounting set, the user must ensure a shim is placed properly in the centre of the bottom plate of 16103.5 before mounting and levelling. The shim allows smooth levelling.

- 1) Loosen 16103.5's countersunk set screw with a 4 mm hex key by turning the hex key counterclockwise until the screw is slightly protruding (sticking out).
- 2) Mount the ball levelling to a 29mm Ø-bore hole
- 3) Place 16103.5 on the ball levelling mount by gently pushing the sensor onto the ball head until it clicks.
- 4) 16103.5 can now be rotated 360° on its ball head by hand. This rotation allows easy cable orientation adjustment. It can be tilted up to 10°. This allows angle compensation on non-horizontal surfaces up to 10°.
- 5) When 16103.5 is mounted and levelled, judging by its bubble level, lock the ball head mechanism by turning the set screw clockwise with the 4 mm hex key until it is tightened. 16103.5 is now locked in its position.

4.5 Placing and removing 16103.5's ball levelling shim

For mounting 16103.5 to ball levelling set, the user must ensure a dedicated shim is placed properly in the centre of the bottom plate of 16103.5. The aluminum shim ensures a secure fit between 16103.5 and ball levelling and allows the ball head to rotate smoothly for easy levelling. The shim and two PG21 nuts are included when ordering the ball levelling set 32.14627.006000.

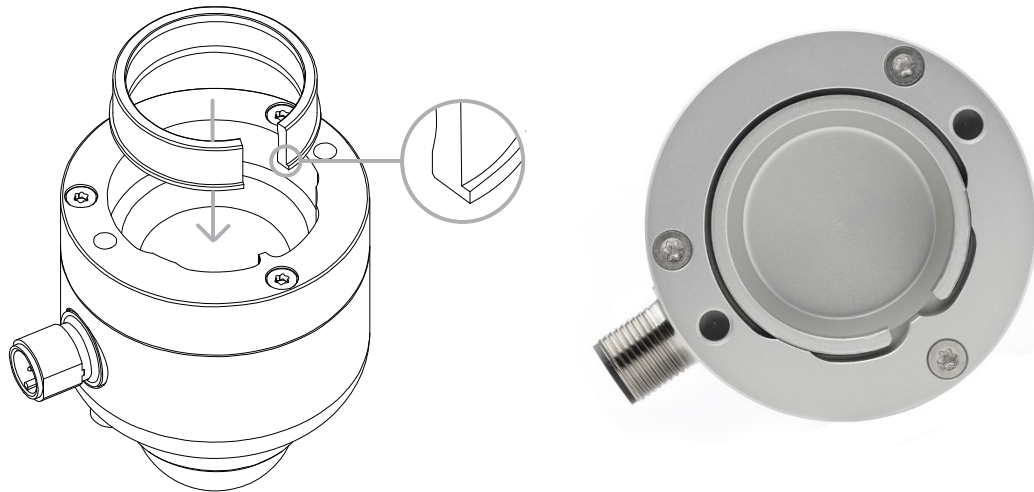

Figure 4.5.1 Line drawing indicating placement of the aluminum shim and photo showing the shim properly positioned in the centre of 16103.5's bottom plate. Note the position of the protruding ledge when placing the shim.

The shim can be placed into 16103.5's bottom plate following these steps:

- 1) Loosen the set screw with a 4 mm hex key by turning the hex key counterclockwise until the screw is only slightly protruding (sticking out).
- 2) Hold 16103.5 in one hand, the shim in the other.
- 3) Ensure the orientation of the shim fits with that of 16103.5's bottom plate. Note the position of the protruding ledge (see figure 4.5.1).
- 4) Pinch the shim slightly to reduce its diameter and to make it fit easily into 16103.5's bottom plate.
- 5) While pinching, push the shim into its position on 16103.5's bottom plate.
- 6) Mount the ball levelling with its mounting nuts.
- 7) 16103.5, with its shim positioned, can now be placed on the ball levelling mount. Gently push the sensor onto the ball head until it clicks.
- 8) The ball head can be rotated 360° and allows angle compensation on non-horizontal surfaces up to 10°.
- 9) When 16103.5 is mounted and levelled, judging by its bubble level, lock the ball head mechanism by turning the set screw clockwise with a 4 mm hex key until it is tightened. The set screw should be countersunk and not protruding (not sticking out).

When the ball head is not inserted in 16103.5, the shim makes a minor rattling noise when moving 16103.5. This is normal, caused by mechanical freedom between the two parts.

The shim can be removed from 16103.5's bottom plate by hand with the assistance of a small flathead screwdriver. Let the screwdriver gently tip the shim out. When removing or placing the shim, make sure the glass dome is protected at all times.

4.6 Electrical connection of active 16103.5 series: wiring diagram

The pyranometers 00.16103.501060 and 00.16103.501040 must be powered by an external power supply, providing an operating voltage in the range from 5 to 30 VDC. Version 00.16103.501060 offers irradiance in W/m^2 as a digital output (Modbus over RS-485) and as an analogue 0 to 1 V output. Version 00.16103.501040 offers irradiance as an analogue 4 to 20 mA output.

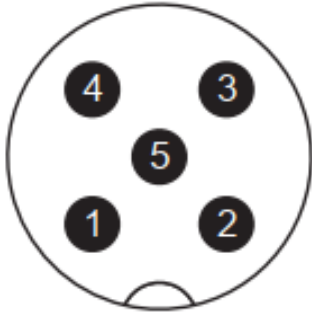

Figure 4.6.1 Front side plug connector M12

4.6.1 Wiring diagram 00.16103.501060 - Modbus RTU or 0...1V

Table 4.6.1.1 Wiring diagram of 00.16103.501060

PIN	WIRE	00.16103.501060 Modbus over RS-485	00.16103.501060 0 to 1 V output
1	Brown	VDC [+]	VDC [+]
2	White	VDC [-]	VDC [-]
3	Blue	RS-485 B / B' [+]	not connected
4	Black	RS-485 A / A' [-]	not connected
5	Grey	not connected	0 to 1 V output
	Shield mesh	shield	shield

Note 1: at the connector-end of the cable, the shield is connected to the connector housing

Note 2: it is not possible to use 00.16103.501060's digital and analogue outputs at the same time

4.6.2 Wiring diagram 00.16103.501040 - 4...20mA

Table 4.6.2.1 Wiring diagram of 00.16103.501040

PIN	WIRE	00.16103.501040 Modbus over TTL on request	00.16103.501040 4 to 20 mA output
1	Brown	-	VDC [+]
4	Black	-	not connected
3	Blue	-	4 to 20 mA output
2	White	-	not connected
5	Grey	-	not connected
	Shield mesh	-	shield

Note 1: at the connector-end of the cable, the shield is connected to the connector housing

4.7 Electrical connection of passive 16103.5: wiring diagram

16103.5 is a passive sensor that does not need any power. Cables generally act as a source of distortion, by picking up capacitive noise. We recommend keeping the distance between a datalogger or amplifier and the sensor as short as possible. For cable extension, see the appendix on this subject.

Table 4.7.1 Wiring diagram of 00.16103.501000

PIN	WIRE	00.16103.501000 Analogue millivolt output
1	Brown	not connected
4	Black	not connected
3	Blue	not connected
2	White	signal [+]
5	Grey	signal [-]
	Shield mesh	shield

4.8 Grounding and use of the shield

Grounding and shield use are the responsibility of the user. The cable shield (called shield in the wiring diagram) is connected to the aluminum instrument body via the connector. In most situations, the instrument will be bolted on a mounting platform that is locally grounded. In these cases, the shield at the cable end should not be connected at all. When a ground connection is not obtained through the instrument body, for instance in laboratory experiments, the shield should be connected to the local ground at the cable end. This is typically the ground or low voltage of the power supply or the common of the network. In exceptional cases, for instance when both the instrument and a datalogger are connected to a small size mast, the local ground at the mounting platform is the same as the network ground. In such cases ground connection may be made both to the instrument body and to the shield at the cable end.

4.9 Using 00.16103.501040's analogue 4 to 20 mA output

16103.5 gives users the option to use 4 to 20 mA output instead of its digital output. When using 4 to 20 mA output, please read this chapter first.

Using the 4 to 20 mA output provided by 00.16103.501040 is easy. The instrument can be connected directly to commonly used data-logging systems.

The irradiance, E , in W/m^2 is calculated by the formula:

$$E = 1600 \cdot (I - 4 \times 10^{-3} A) / (16 \times 10^{-3} A)$$

I: Current output in A
E: Solar irradiance in W/m^2

By convention $0 W/m^2$ irradiance corresponds with $4 \times 10^{-3} A$ transmitter output current I . The transmitted range, which is the irradiance at output current of $20 \times 10^{-3} A$, and is typically $1600 W/m^2$.

It is important to realize that the signal wires not only act to transmit the signal but also act as power supply for the 4-20 mA current loop circuit!

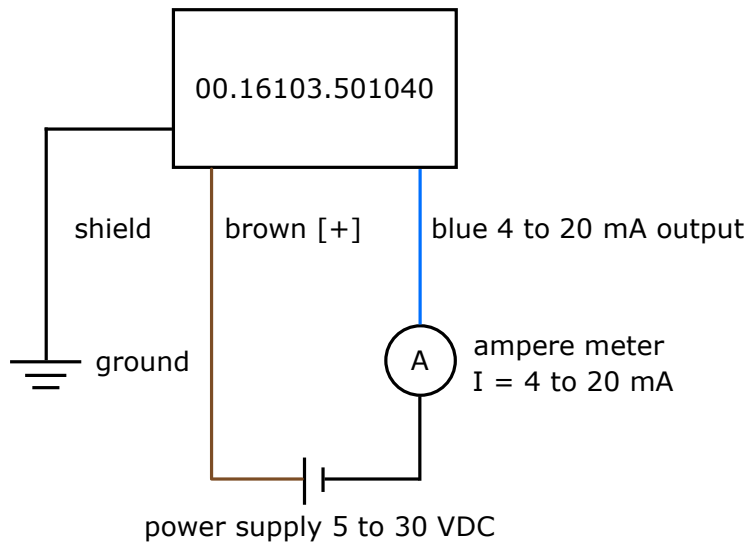

Figure 4.9.1 Electrical diagram of the connection of 00.16103.501040 to a typical ampere meter or datalogger with capability to measure current signals.

Usually a $100\ \Omega$ shunt resistor (R) is used to convert the current to a voltage (this will then be in the 0.4 – to 2 VDC range). This resistor must be put in series with the blue wire of the sensor.

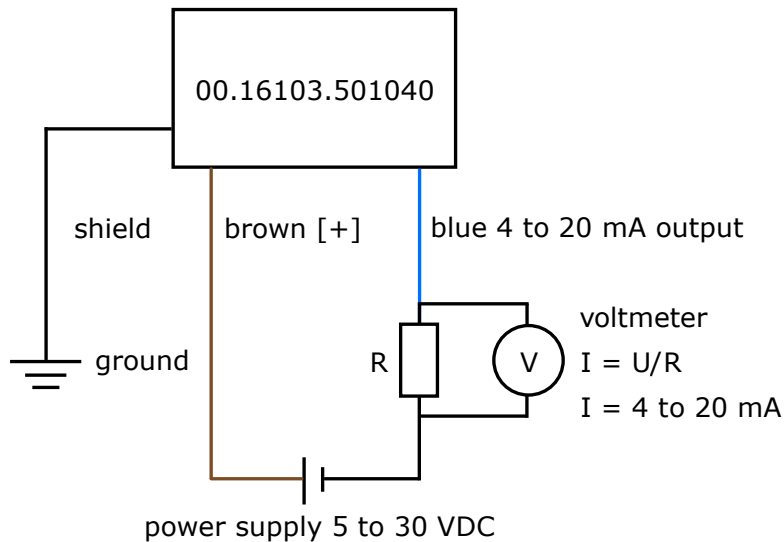

Figure 4.9.2 Electrical diagram of the connection of 00.16103.501040 to a typical voltmeter or datalogger with the capability to measure voltage signals.

4.10 Using 00.16103.501060's analogue 0 to 1 V output

00.16103.501060 gives users the option to use 0 to 1 V output instead of its digital Modbus RTU output. When using 0 to 1 V output, please read this chapter first. The use of the Modbus RTU output is described in the next chapter.

Using the 0 to 1 V output provided by 00.16103.501060 is easy. The instrument can be connected directly to commonly used data logging systems.

The irradiance, E , in W/m^2 is calculated by the formula:

$$E = 1600 \cdot U$$

U: Voltage output in V

E: Solar irradiance in W/m^2

By convention 0 W/m^2 irradiance corresponds with 0 V transmitter output voltage. The transmitted range, which is the irradiance at output voltage of 1 V, and is typically 1600 W/m^2 .

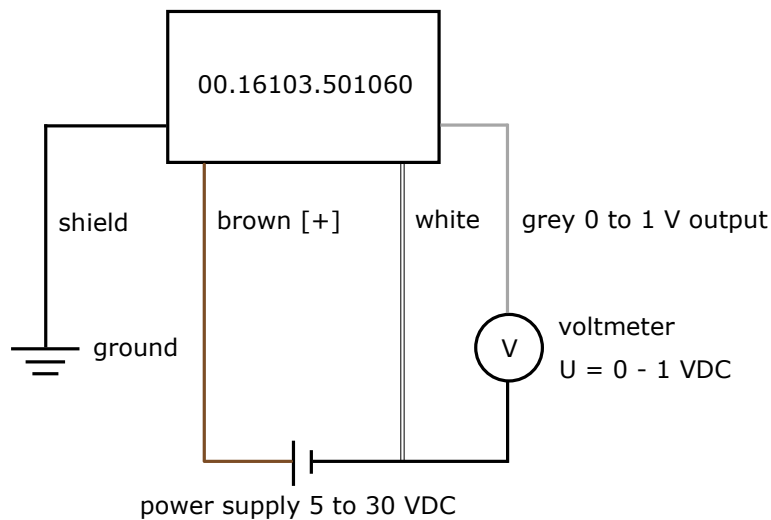

Figure 4.10.1 Electrical diagram of the connection of 00.16103.501060 to a typical voltmeter or data-logger with the capability to measure voltage signals.

4.11 Connecting 00.16103.501060 to an RS-485 network

When using 16103.5's digital output, 00.16103.501060 can be connected to a (half-duplex) RS-485 network. In such a network 00.16103.501060 acts as a slave, receiving data requests from the master. An example of the connection to an RS-485 two-wire network is shown in the figure below. 00.16103.501060 is powered from 5 to 30 VDC. The power supply is not shown in the figure. In case of separate power supply of devices in the network the VDC [-] power supply ground must be connected to the common line of the network. [*Modbus over serial line specification and implementation guide V1.02 (www.modbus.org).*]

After the last nodes in the network, on both sides, line termination resistors (LT) are required to eliminate reflections in the network. According to the RS-485 standard, these LT have a typical value of 120 to 150 Ω . Never place more than two LT on the network and never place the LT on a derivation cable.

Note: To minimise noise on the network when no transmission is occurring, a pull up and pull down resistor are required. Typical values for both resistors are in the range from 650 to 850 Ω .

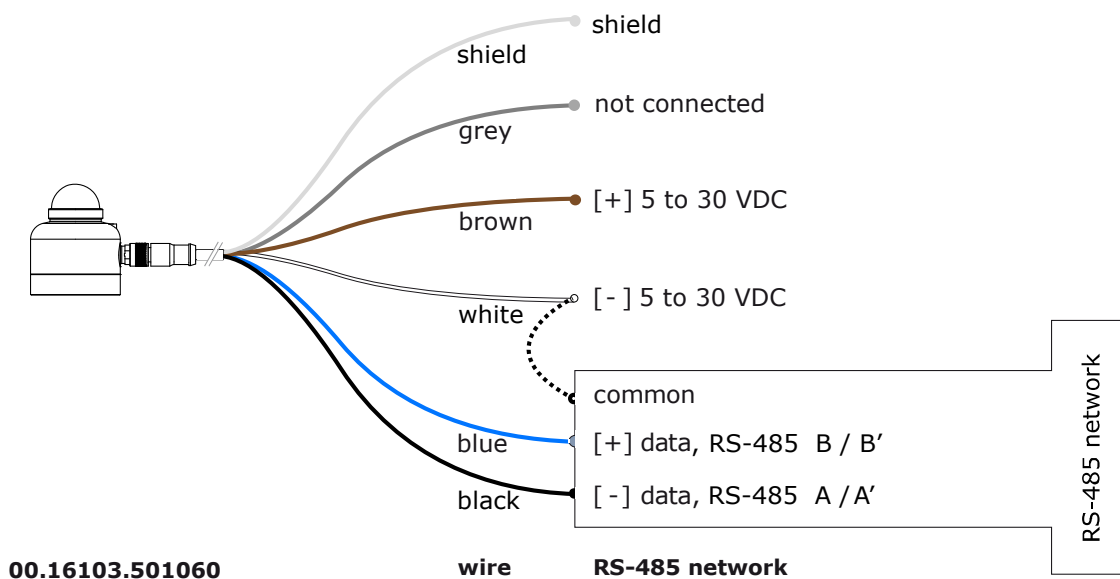

Figure 4.11.1 Connection of 00.16103.501060 to an RS-485 network. 00.16103.501060 is powered by an external power supply of 5 to 30 VDC.

5 Modbus RTU Communication with 00.16103.501060

5.1 Modbus-protocol

The Lambrecht meteo Modbus sensors and the met[LOG] follow the specification of the Modbus organization: "MODBUS APPLICATION PROTOCOL SPECIFICATION V1.1b3". (See www.modbus.org).

5.2 Data encoding

MODBUS uses the "big-endian" format for addresses and data. This means that if a value is transmitted with a number format that is larger than a single byte, the "most significant byte" is sent first. For values that go beyond one register (e.g. 32 bit) this is not clearly specified for the Modbus. In these cases (32 bit or 64 bit) the LAMBRECHT Modbus sensors follow the big-endian number format.

Example Big-Endian:

Register size value

16 - bits 0x1234 is transmitted in the order: 0x12 0x34.

Example big-endian (32bit or 64bit):

Register size value

32 - bits 0x12345678 is transmitted in the order: 0x12 0x34 0x56 0x78.

5.3 Device-address

The addresses 1...247 are permitted for Modbus.

Warning: Using the same Modbus address for more than one device will lead to irregular behaviour of the entire network.

5.4 Standard configuration - default

Baud rate: 19200 Baud

Address: Each sensor type (or family) has its own default address.

Table 5.4.1 Default addresses of the Lambrecht sensors

Address	Sensor
1	Wind speed
2	Wind direction
3	Precipitation rain[e]
4	THP
5	EOLOS IND
6	com[b]
7	PREOS
8	ARCO
9	u[sonic]
10	Pyranometer 2nd Class
11	Secondary standard Pyranometer
12	PT100 to Modbus converter (temperature)

Byte frame according to MODBUS standard for RTU mode:
8E1 (1 start bit, 8 data bits, 1 parity bit (even parity), 1 stop bit)

5.5 Modbus command set

The Lambrecht Modbus sensors support the following commands:

- Read Input Register" command: 0x04 (Read measured data)
- Write Multiple Register" command: 0x10 (Write sensor data)

5.6 Measured value and parameter register

The LAMBRECHT meteo Modbus provides in the register range 30001 to the measured values. The register addresses 30001 to 35000 apply to all LAMBRECHT meteo Modbus sensors, but are only available or valid if the respective sensor supports the corresponding values (e.g. a pure wind sensor does not provide any air humidity).

Table 5.6.1 Measured values provided by 00.16103.501060

Register address	Parameter name	Unit	Factor	Description	Data type
31401	Global radiation instantaneous values	W/m ²	10	1 decimal	INT
31402	Global radiation - average value since last retrieval	W/m ²	10	1 decimal	INT
31403	Global radiation - maximum value since last retrieval	W/m ²	10	1 decimal	INT
31404	Global radiation - minimum value since last retrieval	W/m ²	10	1 decimal	INT
31501	Global radiation instantaneous values (High-WORD) (temperature compensated)	W/m ²	100	2 decimal The register 31501 + 31502 should be read in one sequence. (function code 0x04)	LONG
31502	Global radiation instantaneous values (Low-WORD) (temperature compensated)				

Register 31501 + 31502, Global radiation instantaneous values (Irradiance), provides the solar radiation output in 0.01 W/m². The value given must be divided by 100 to get the value in W/m². MSW and LSW should be read together in one request.

Note: The values from the registers with the maximum values (31403) and minimum values (31404) are automatically reset as soon as the register (31402) with the mean values has been read out.

The Lambrecht sensors give 0xD8F1=-9999(16bit) or 0xFF676981=-9999999 (32bit) as error code or invalid value.

Note: Individual readout of related registers (e.g. 31501 and 31502) is not permitted.

5.7 Sensor parameters / configuration-parameters

Table 5.7.1 Configuration registers

Register address	Parameter name	Unit	Divisor	Description	Data type
40001	Modbus device address		1	The addresses 1...247 are allowed.	INT
40200	Baud rate		0,01	96=9600 192=19200 384=38400	INT
46000	Number of mapping-registers*		1	Contains the number of occupied mapping registers for the autoconfiguration 16103.5 = 6	INT

* For more information about the registers for auto-configuration see Appendix.

Register 40001, Modbus device address, contains the Modbus address of the sensor. This allows the Modbus master to detect the slave in its network. The address can be changed; the value of the address must be between 1 and 247. The default Modbus address is 10.

Note: The sensor needs to be restarted before changes become effective.

Register 40200, Baud rate, is used to enter the settings for the baud rate. The framing of the serial data transfer is 8 data bits, even parity and 1 stop bit. Default setting is 19200 baud.

Note: The sensor needs to be restarted before changes become effective.

Table 5.7.2 Format of data

FORMAT OF DATA	DESCRIPTION
uINT	Unsigned 16 bit integer
INT	Signed 16 bit integer
uLONG	Unsigned 32 bit integer
LONG	Signed 32 bit integer

The data format includes *signed* and *unsigned* integers. The difference between these types is that a *signed* integer passes on negative values, which reduces the range of the integer by half. Up to five 16 bit registers can be requested in one request; if requesting six or more registers, multiple requests should be used.

If the format of data is a signed or an unsigned 32 bit integer, the first register received is the most significant word (MSW) and the second register is the least significant word (LSW). This way two 16 bit registers are reserved for a 32 bit integer. MSW and LSW must be read together in one request. This is necessary to make sure both registers contain the data of one internal measurement.

5.8 Network communication: getting started

Once it has the correct Modbus address and communication settings, 00.16103.501060 can be connected directly to an RS-485 network and a power supply.

Installing a pyranometer 00.16103.501060 in the network also requires configuring the communication for this new Modbus device. This usually consists of defining a request that can be broadcast by the master.

Typical operation requires the master to make a request of irradiance data in registers 31501 + 31502 every 1 second and store the 60 second averages. The data format of register 31501 + 31502 is a signed 32 bit integer.

Note: Up to five 16 bit registers can be requested in one request. In case six or more registers are requested in just one request, the pyranometer will not respond. If requesting six or more registers, multiple requests should be used: the pyranometer will respond as expected.

5.9 Adapting the Modbus address and communication settings

Setting the instrument address and baud rate can be done in different ways:

- by connecting the sensor to the PC and using a Modbus testing tool. There are links to different solutions available at www.modbus.org;
- by using the available network user interface software.

The Modbus address is stored in register 40001 and has a default value of 11. A user may change the address to a value in the range of 1 to 247. The address value must be unique in the network. The communication settings are stored in register 1.

The default communication frame is 19200 baud, with even parity bit, 8 data bits and 1 stop bit. After a new address or communication setting is written the sensor must be restarted.

6 Maintenance and trouble shooting

6.1 Recommended maintenance and quality assurance

16103.5 can measure reliably at a low level of maintenance in most locations. Usually, unreliable measurements will be detected as unreasonably large or small measured values. Generally this means that regular visual inspection combined with a critical review of the measured data, preferably checking against other measurements, is the preferred way to obtain a reliable measurement.

Table 6.1.1 Recommended maintenance of 16103.5. If possible the data analysis and cleaning (1 and 2) should be done on a daily basis.

MINIMUM RECOMMENDED PYRANOMETER MAINTENANCE			
	INTERVAL	SUBJECT	ACTION
1	1 week	data analysis	Compare measured data to maximum possible / maximum expected irradiance and to other measurements nearby (redundant instruments). Also, historical seasonal records can be used as a source for expected values. Analyze night time signals. These signals may be negative (down to - 5 W/m ² on clear windless nights), due to zero offset a. In case of use with PV systems, compare daytime measurements to PV system output. Look for any patterns and events that deviate from what is normal or expected
2	2 weeks	cleaning	Use a soft cloth to clean the dome of the instrument, persistent stains can be treated with soapy water or alcohol
3	6 months	inspection	Inspect cable quality, inspect connectors, inspect mounting position, inspect cable, clean instrument, clean cable, inspect levelling, change instrument tilt in case this is out of specification, inspect mounting connection, inspect interior of dome for condensation
4	2 years	desiccant replacement	Desiccant is specified to last for a minimum of 2 years. In case the user wants to replace desiccant himself, this is at own risk and should only be executed in an ESD-safe work environment. The bottom plate of 16103.5 should be removed by unscrewing 3 x T10 screws with a Torx 10 screwdriver. The desiccant bag is taped on the bottom plate of 16103.5. Care should be taken when mounting the bottom plate on 16103.5
5	2 years	recalibration	Recalibration by side-by-side comparison to a higher standard instrument in the field according to ISO 9847
6		lifetime assessment	Judge if the instrument should be reliable for another 2 years, or if it should be replaced
7	6 years	parts replacement	If applicable / necessary, replace the parts that are most exposed to ageing and weathering, cable, connector. NOTE: use manufacturer approved parts only.

6.2 Trouble shooting

Table 6.2.1 *Trouble shooting for 00.16103.501060 and 00.16103.501040*

General	<p>Inspect the instrument for any damage.</p> <p>Inspect if the connector is properly attached.</p> <p>Check the condition of the connectors (on chassis as well as the cable).</p> <p>Inspect if the sensor receives DC voltage power in the range of 5 to 30 VDC.</p> <p>Inspect the connection of the shield (typically not connected at the network side).</p> <p>Inspect the connection of the sensor power supply, typically the GND (-) is connected to the network <i>common</i>.</p>
The sensor does not give any signal	<p>Check if the sensor reacts to light: expose the sensor to a strong light source, for instance a 100 W light bulb at 0.1 m distance. The signal should read $> 100 \text{ W/m}^2$ now. Darken the sensor either by putting something over it or switching off the light. The instrument voltage output should go down and within one minute approach 0 W/m^2. Check the data acquisition by replacing the sensor with a spare sensor with the same address.</p>
Not able to communicate with the sensor	<p>Check all physical connections to the sensor and try connecting to the sensor again. If communicating is not possible, try to figure out if the address and communication settings are correct. Analyze the cable performance by measuring resistance from pins to cable ends. The electrical resistance should be $< 10 \Omega$. In case of doubt, try a new cable.</p> <p>If all physical connections are correct, and the sensor still cannot be found, please contact the factory to send the sensor to the manufacturer for diagnosis and service.</p>
The sensor signal is unrealistically high or low	<p>Note that night-time signals may be negative (down to -5 W/m^2 on clear windless nights), due to zero offset a.</p> <p>Check if the pyranometer has a clean dome.</p> <p>Check the location of the pyranometer; are there any obstructions that could explain the measurement result.</p> <p>Check the orientation / levelling of the pyranometer.</p> <p>Check the cable condition looking for cable breaks. Check the condition of the connectors (on chassis as well as the cable).</p>
The sensor signal shows unexpected variations	<p>Check the presence of strong sources of electromagnetic radiation (radar, radio).</p> <p>Check the condition and connection of the shield.</p> <p>Check the condition of the sensor cable.</p> <p>Check if the cable is not moving during the measurement.</p> <p>Check the condition of the connectors (on chassis as well as the cable)</p>
The dome shows internal condensation	<p>Arrange to send the sensor back to LAMBRECHT for diagnosis.</p>

Table 6.2.2 *Trouble shooting for 00.16103.501000*

The sensor does not give any signal	<p>Check the electrical resistance of the sensor between the grey (-) and white (+) wire. Use a multimeter at the 200 Ω range. Measure the sensor resistance first with one polarity, then reverse the polarity. Take the average value. The typical resistance of the wiring is 0.1 Ω/m. The measured resistance should be the typical sensor resistance of 40 to 80 Ω plus 1 Ω for the total resistance of two wires (back and forth) of each 3 m. Infinite resistance indicates a broken circuit; zero or a low resistance indicates a short circuit.</p> <p>Check if the sensor reacts to light: put the multimeter at its most sensitive range of DC voltage measurement, typically the 100 x 10⁻³ VDC range or lower. Expose the sensor to strong light source, for instance a 100 W light bulb at 1 x 10⁻¹ m distance. The signal should read > 2 x 10⁻³ V now. Darken the sensor either by putting something over it or switching off the light. The instrument voltage output should go down and within one minute approach 0 V. Check the data acquisition by applying a 1 x 10⁻⁶ V source to it in the 1 x 10⁻⁶ V range. Check the condition of the connectors (on chassis as well as the cable).</p>
The sensor signal is unrealistically high or low.	<p>Note that night-time signals may be negative (down to -5 W/m² on clear windless nights), due to zero offset a.</p> <p>Check if the pyranometer has clean domes.</p> <p>Check the location of the pyranometer; are there any obstructions that could explain the measurement result.</p> <p>Check the orientation / levelling of the pyranometer.</p> <p>Check if the right calibration factor is entered into the algorithm. Please note that each sensor has its own individual calibration factor, as documented in its calibration certificate.</p> <p>Check if the voltage reading is divided by the calibration factor in review of the algorithm. Check the condition of the wiring at the logger.</p> <p>Check the cable condition looking for cable breaks. Check the condition of the connectors (on chassis as well as the cable). Check the range of the data logger; signal can be negative (this could be out of range) or the amplitude could be out of range. Check the data acquisition by applying a 1 x 10⁻⁶ V source to it in the 1 x 10⁻⁶ V range. Look at the output. Check if the output is as expected.</p> <p>Check the data acquisition by short circuiting the data acquisition input with a 100 Ω resistor. Look at the output. Check if the output is close to 0 W/m².</p>
The sensor signal shows unexpected variations	<p>Check the presence of strong sources of electromagnetic radiation (radar, radio)</p> <p>Check the condition of the shielding.</p> <p>Check the condition of the sensor cable.</p> <p>Check if the cable is not moving during the measurement</p> <p>Check the condition of the connectors (on chassis as well as the cable)</p>
The dome shows internal condensation	<p>Arrange to send the sensor back to LAMBRECHT for diagnosis.</p>

7 Appendices

7.1 Appendix on cable extension / replacement

The sensor cable of the 16103.5 series is equipped with a M12-A straight connector. In case of cable replacement, it is recommended to purchase a new cable with connector at LAMBRECHT or Phoenix Contact. In case of cable extension, it is recommended to purchase an extension cable with connector pairs at LAMBRECHT. Please note that LAMBRECHT does not provide support for Do-It-Yourself connector- and cable assembly.

The Maximum length of the sensor cable depends on the RS-485 network topology applied in the field. In practice, daisy chain topologies or point to point (PtP) topologies are used. The length of the sensor cable should be as short as possible to avoid signal reflections on the line, in particular in daisy chain configurations.

In point to point configurations cable lengths can in theory be much longer; RS-485 is specified for cable lengths up to 1200 meters.

7.2 LAMBRECHT meteo – Auto-configuration

The Modbus sensors from LAMBRECHT meteo offer the possibility of auto-configuration. This is supported e.g. by the LAMBRECHT meteo data logger met[LOG]. For the auto-configuration, the register addresses of the measured values and sensor data available in the register range 30001 to 35000 are listed as successive values in the Lambrecht sensors in register range 46001 to 49000. Registers 46001 to 49000 can only be read out as a block! The length of the block or the number of available mapping registers is in holding register 46000.

Table 7.2.1 Number of mapping-registers

Register address	Parameter name	Unit	Divisor	Description	
46000	Number of mapping-registers		1	Contains the number of occupied mapping registers for the autoconfiguration 16103.5 = 6	INT

Since the addresses from the range 30001 to 35000 apply to all Lambrecht sensors, an address from this range is also representative of a measured value type.

For example, register 30401 always contains the current value of the air temperature. If this register address is not included in the list in register range 46001 to 49000, the connected Modbus sensor does not supply an air temperature.

If the auto-configuration is started with the data logger met[LOG], it queries the available mapping registers on each COM interface in the device address range 1...25. For this purpose, the number of mapping registers is read from register 46000 and the register range starting at 46001 is read out as a block.

The following table contains the assignment of the configuration to the individual (possible) instantaneous value registers of the sensors. Some sensors deliver registers with mean (average), minimum and maximum values or additional values beyond this specification. Unknown register addresses (or registers that are not required) must therefore be ignored during auto-configuration.

Table 7.2.2 Standard registers for auto-configuration

Register address	Parameter name	Unit	Factor	Description	Data type	Function-code	Storage-type >16 bit
30001	Wind speed instantaneous value	m/s	10	1 decimal place	INT	0x04	Big-Endian WORD
30201	Wind direction instantaneous value	°	10	1 decimal place	INT	0x04	Big-Endian WORD
30401	Air temperature instantaneous value	°C	10	1 decimal place	INT	0x04	Big-Endian WORD
30601	Humidity instantaneous value	%r.h.	10	1 decimal place	INT	0x04	Big-Endian WORD
30701	Dew point instantaneous value	°C	10	1 decimal place	INT	0x04	Big-Endian WORD
30801	Air pressure instantaneous value	hPa	10	1 decimal place	INT	0x04	Big-Endian WORD
31001	Precipitation amount total	mm	10	1 decimal place	INT	0x04	Big-Endian WORD
31101	Precipitation amount total (High-WORD)	mm	1000	3 decimal places Registers 31101 + 31102 can only be read out together. (function code 0x04)	LONG	0x04	Big-Endian LONG
31102	Precipitation amount total (Low-WORD)					0x04	
31201	Precipitation intensity 1-minute sliding	mm/min	1000	= average (1-min.) 3 decimal places Time base = 1 min. Meas. rate =6x per min.	INT	0x04	Big-Endian WORD
31401	Global radiation instantaneous value	W/m ²	10	1 decimal place	INT	0x04	Big-Endian WORD
31501	Global radiation instantaneous values (High-WORD) (temperature compensated)	W/m ²	100	2 decimal places Registers 31501 + 31502 can only be read out together. (function code 0x04)	LONG	0x04	Big-Endian WORD
31502	Global radiation instantaneous values (Low-WORD) (temperature compensated)					0x04	
31591	Global radiation instantaneous values (High-WORD) (uncompensated)	W/m ²	100	2 decimal places Registers 31591 + 31592 can only be read out together. (function code 0x04)	LONG	0x04	Big-Endian WORD
31592	Global radiation instantaneous values (Low-WORD) (uncompensated)					0x04	

Registers Address 46001-49000 containing for each sensor the available registers with measured values and sensor data from the range 30001-35000.

The registers can only be read out as a block! The length of the block or the number of available mapping registers is in holding register 46000

For example, the registers 46001 to 46006 of 16103.5 contain valid addresses. The holding register 46000 contains the number of registers “6”, all 6 registers must be read out in the block with the function code 0x04. Too many registers or too few lead to an error message.

Table 7.2.3 Mapping-Register for auto-configuration

Register address	Register value	Unit	Factor	Description	
46001	31401	Register address	1	Global radiation instantaneous values	INT
46002	31402	Register address	1	Global radiation - average value since last retrieval	INT
46003	31403	Register address	1	Global radiation - maximum value since last retrieval	INT
46004	31404	Register address	1	Global radiation - minimum value since last retrieval	INT
46005	31501	Register address	1	Global radiation instantaneous values (High-WORD) (temperature compensated)	INT
46006	31502	Register address	1	Global radiation instantaneous values (Low-WORD) (temperature compensated)	INT

Note 1: Usually, maximal up to five 16 bit registers can be requested from pyranometer 00.16103.501060 in one request. Just the 6 mapping registers for the auto-configuration can be requested in one request. For all other registers applies “if requesting six or more registers, use multiple requests”.

7.3 EU declaration of conformity



We, **LAMBRECHT meteo GmbH.**
Friedlaender Weg 65-67
37085 Goettingen
Germany

in accordance with the requirements of the following directive:

2014/30/EU The Electromagnetic Compatibility Directive

hereby declare under our sole responsibility that:

Product model: 00.16103.501000, 00.16103.501040, 00.16103.501060
Product type: Pyranometer

has been designed to comply and is in conformity with the relevant sections and applicable requirements of the following standards:

Emission: IEC/EN 61000-6-1, Class B, RF emission requirements, IEC CISPR11
and EN 55011 Class B requirements

Immunity: IEC/EN 61000-6-2 and IEC 61326 requirements

Date of test: 2 January 2017

Copyright © 2025 LAMBRECHT meteo GmbH. All rights reserved.
Information in this document subject to change without notice.
Photo copyright: © danielschoenen - Adobe stock
16103_5_Manual 06.25

LAMBRECHT meteo GmbH
Friedländer Weg 65
37085 Göttingen
Germany

Tel +49-(0)551-4958-0
E-Mail info-lambrecht@aem.eco
Internet www.lambrecht.net