



USER MANUAL

# PRO-WEA

Wind Sensors



# Content

|   |    |
|---|----|
| Warranty  | 2  |
| Features of the PRO-WEA wind sensors                      | 3  |
| Initial operation   | 3  |
| Choose installation site                                  | 3  |
| Mounting of the cup rotor and the wind vane at the sensor | 4  |
| Mounting options  | 4  |
| Adjusting the wind vane to the north                      | 5  |
| Electrical connection                                     | 5  |
| Heating   | 6  |
| Maintenance   | 6  |
| Disposal  | 6  |
| Technical data - Cable                                    | 7  |
| Dimensional drawings                                      | 7  |
| Electrical connection                                     | 9  |
| Technical data - Sensors                                  | 10 |

## Warranty

**Please note the loss of warranty and non-liability by unauthorized manipulation of the system. You need a written permission of the LAMBRECHT meteo GmbH for changes of system components. These activities must be operated by a qualified technician.**

The warranty does not cover:

1. Mechanical damages caused by external impacts (e. g. icefall, rockfall, vandalism).
2. Impacts or damages caused by over-voltages or electromagnetic fields which are beyond the standards and specifications in the technical data.
3. Damages caused by improper handling, e. g. by wrong tools, incorrect installation, incorrect electrical installation (false polarity) etc.
4. Damages which are caused by using the device beyond the specified operation conditions.



## Features of the PRO-WEA wind sensors

The PRO-WEA wind sensor pair for determining wind direction and wind speed was specially developed for use on wind turbines.

- Improved electrostatic discharge protection for use in lightning-prone areas
- Year-round use on wind turbines in most climatic zones due to integrated, controlled heating system
- Particularly robust and durable due to reinforced axle
- The simple cable plug connection is advantageous for quick installation and when service is required

### STANDARDS

- EMC acc. to EN 61000-6-2, EN 61000-6-4, EN 61000-4-2, -3, -4, -5, -6, -11, Namur NE-21
- VDE 0100
- WMO Nr. 8
- VDI 3786 Part 2

## Initial operation

The wind can be represented by a vector quantity. For a complete description of the wind it is necessary to specify its speed and direction. The two components are subject to spatial and temporal variations; thus, strictly speaking, they are valid only for the site where the measuring instrument is put up. We therefore recommend to select the place of installation very carefully.

## Choose installation site

Generally, wind measuring instruments should not measure the specific wind conditions of a limited area, but indicate the typical wind conditions of a wider area. The values measured at different places must be comparable. Thus, when installing the sensor you should make sure the place of installation is not under the lee of great obstacles. The distance between the obstacles and the sensor should be 10 times the height of the obstacles (this corresponds to the definition of an undisturbed terrain).

If an undisturbed terrain of this kind does not exist the sensor must be put up at a height of at least 5 m above the obstacle height. If the sensor must be installed on a roof top the place of installation must be in the middle of the roof to avoid predominant wind directions.

If you want to measure both wind direction and wind speed, install the sensors at the same measuring point, if possible, and make sure to avoid any mutual influence of the sensors. A wind sensor pair easily meets this requirement since the sensors are set up side by side. Their horizontal distance should be approximately 1.5 m. The two sensors must be staggered vertically so that the lower edge of the upper wind speed sensor is 0.1 to 0.5 m above the upper edge of the lower wind direction sensor.

## Mounting of the cup rotor and the wind vane at the sensor

The bores at the cup rotor and the wind vane are attached in such a way that they can only be installed in a certain clear position. All 3 screws must be used to fasten the cup rotor resp. the wind vane. Thus the correct direction of rotation is guaranteed. The necessary wrench is included in delivery.

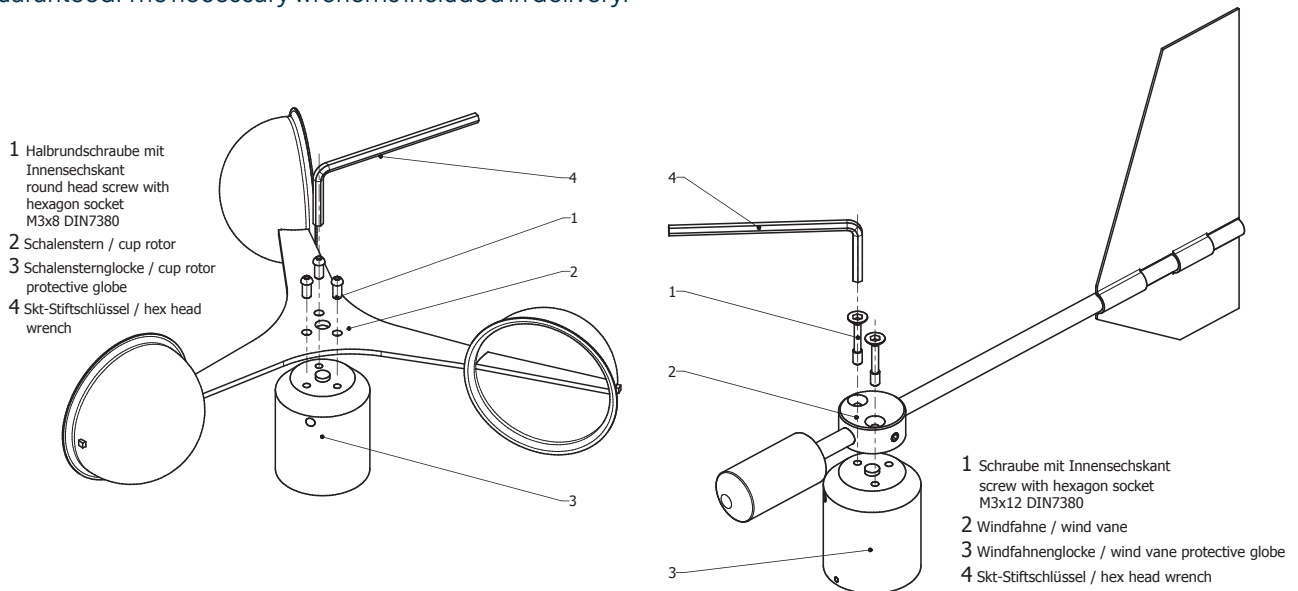

## Mounting options



**Because the installation take place in a dangerous height, the assembly personal must follow the rules for prevention of accidents.**

### I. TRAVERSE WITH SLOTTED BORES

(IdNo.: 32.14567.010000)

The traverse has a slotted hole of  $\varnothing 30$  mm at each of its two ends.

1. Remove the nut from the sensor.
2. Put a sensor with assembled cable sidewise into the bore.
3. Attach the sensor with the flat side of detached nut from the lower side.  
Tighten with a suitable tool (wrench size 40), until a twisting safety of the sensor aligned to the north is given.

### II. MOUNTING IN BORES

The material thickness for mounting the sensor between the nuts must not exceed 10 mm.

1. Remove the thread nut from the sensor.
2. The sensor with cable-plug connection is led without cable into the bore and fastened by the opposite side with the loose nut as under I.3.

⚠ When you install the connecting cables make sure not to excessively shorten the cable leading to the connector in the lower part of the sensor casing so that you can later maintain or dismounting the sensor. Put further a cable loop as sensor protection against water under the sensor.

⚠ Tip: Install the sensors on ground to the traverse and align you the wind vane parallel to the traverse. You go only then upward, in order to accordingly align the sensors with traverse under assistance of a partner on ground.

## Adjusting the wind vane to the north

For wind direction measurements the north mark on the sensor must be aligned with the geographical north direction. You have to turn the marking exactly over the marking at the sensor shaft. When you have aligned the marks, you may fix the wind vane with e.g. a piece of adhesive tape. When you have fixed the wind vane this way you can locate the reference point by aiming at it over the axis. Now you must turn the sensor casing on the mounting tube until the tip of the wind vane points to the reference point in the north.

To set up the sensor's north orientation select a landmark which is as far as possible up north with regard to the final position of the wind direction sensor. The reference point can be selected using a topographical map (1:25000). The exact position of the reference point is determined using an amplitude compass that can be adjusted horizontally on a stand.

⚠ **Beware of compass misdirections.**

When the north direction is set up for the wind direction sensor, you can mounting it as under point "Mounting options". Remove any adhesive tape.

If you cannot select a northern reference point owing to local conditions, you can proceed analogously using a reference point in the south. In this case, however, you have to make sure the north mark on the sensor does not point to the reference point but in the opposite direction.

## Electrical connection

The PRO-WEA sensors are connected to a data measuring system via the open cable end (see example "Cable run"). The connecting cable is suitably led along the mast between the data evaluation device (indicating instrument or data acquisition system) and the sensor. The cable must be fastened using appropriate cable ties (their length depends on the mast diameter). Lead the cable in a wide curve from the mast to the bottom of the casing so that you can later easily dismount the cable.

⚠ Please make sure the cable is protected from humidity on the side of the data processing system. Generally, Pg sockets that use a rubber joint to prevent humidity from penetrating into the terminal box of the data processing system provide sufficient protection.



Example: Cable run by an EMC fair Pg-socket

Alternatively the lead can be laid also completely in the pipes of a mast, if the mast is accordingly prepared.



**To reduce the risk of inductive interference the sensor must be properly grounded (screening on both sides).**

## Heating

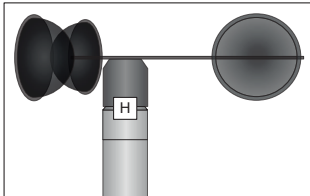

The sensor has an electronically controlled 18 W heating within the sensor head. The heating is supplied together with the sensor electronics. (On request a separate supply of the sensor electronics and the heating by a fixed cable is possible.)

Under most climatological conditions the heating prevents blocking of the moving sensor parts (see illustration). The cup rotor or the wind vane are not heated. In case of icing or formation of ice at the moving sensor element the function is restricted for the period of icing.

## Maintenance

The sensor design permits long periods of maintenance-free operation. We therefore recommend a regular visual verification of the north setup of the wind direction sensor as well as a sensor calibration of both sensor types every two years. With problems, which cannot solve you, do not hesitate to contact our LAMBRECHT meteo service under:

Tel.: +49-(0)551-4958-0

E-mail: support@lambrecht.net

## Disposal

LAMBRECHT meteo GmbH is listed and registered at the Stiftung Elektro-Altgeräte Register ear under:

**WEEE-Reg.-Nr. DE 45445814**

In the category of monitoring and control instruments, device type: "Monitoring and control instruments for exclusively commercial use".

### Within the EU



The device has to be disposed according to the European Directives 2002/96/EC and 2003/108/EC (Waste Electrical and Electronic Equipment). Do not dispose the old device in the household waste! For an environmentally friendly recycling and disposal of your old device, contact a certified disposal company for electronic waste.

### Outside the EU

Please follow the regulations in your country regarding the appropriate disposal of waste electronic equipment.



## Technical data - Cable

ID 32.14567.060000 - Sensor cable with plug connection, length: 12 m

Flame resistance of the cable: acc. to UL Style 20549

### DIMENSIONED DRAWING

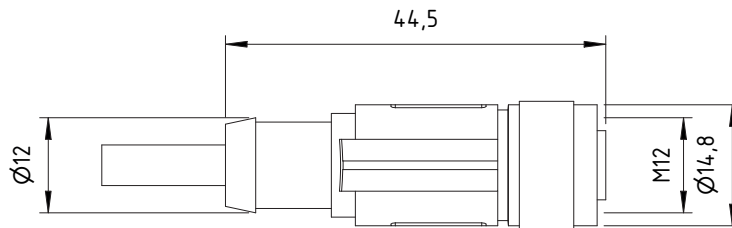

## Dimensional drawings

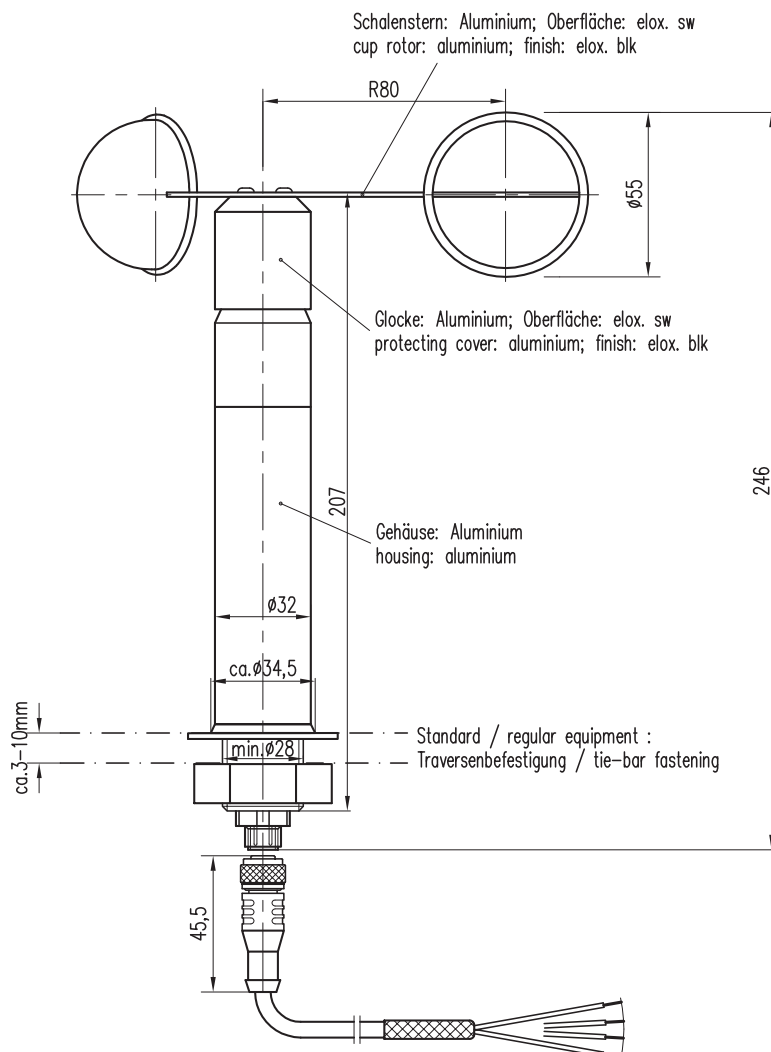

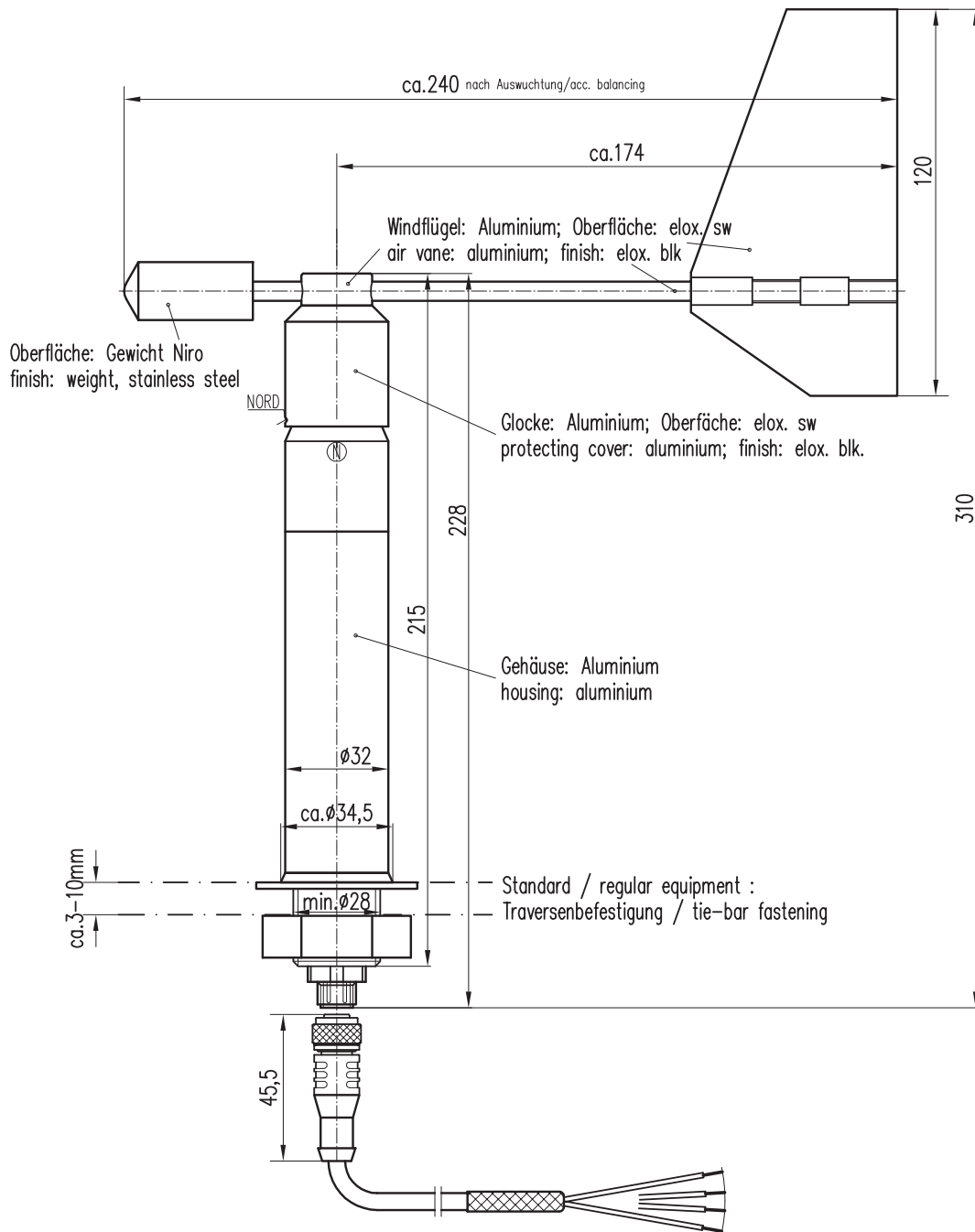

# Electrical connection

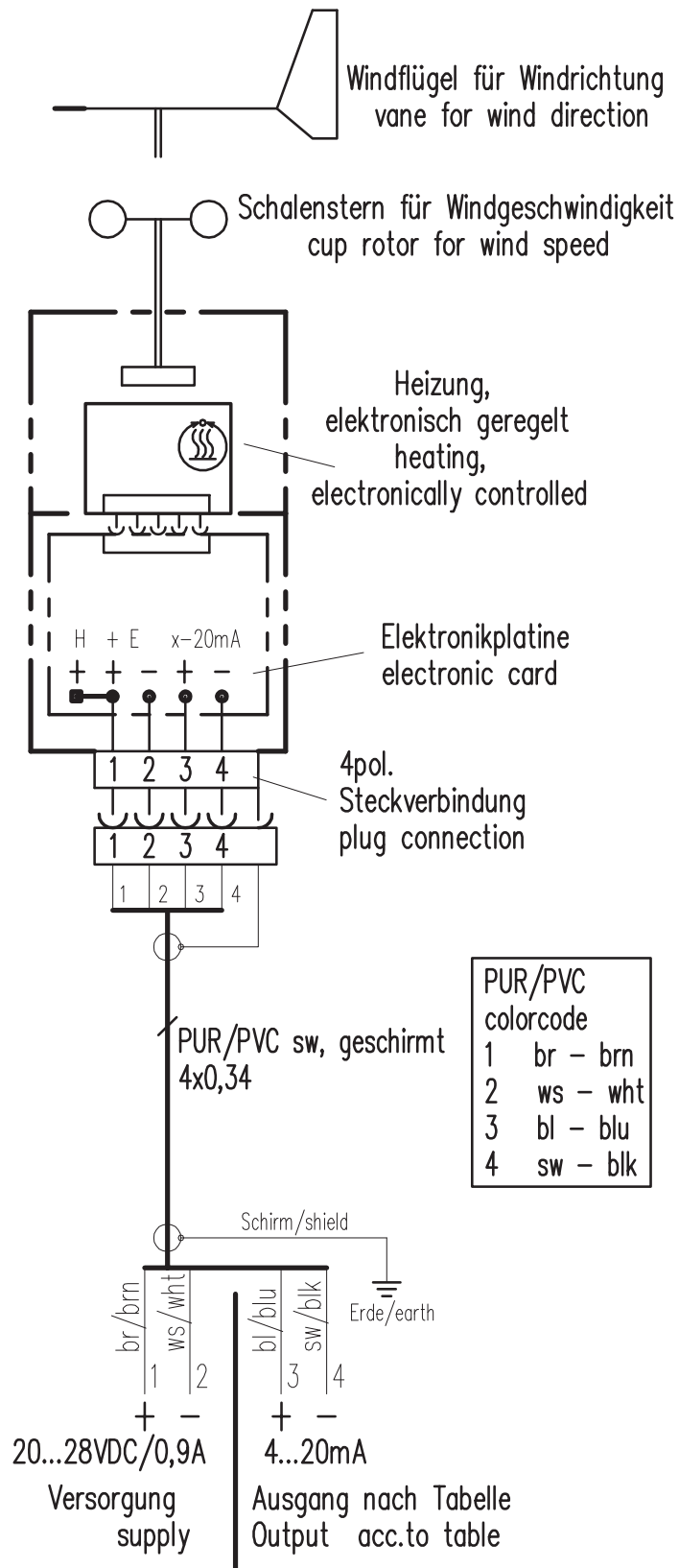

## Technical data - Sensors

|  | PRO-WEA Wind direction sensor   | PRO-WEA Wind speed sensor                           |
|--|---|---|
| ID   | 00.14523.131040   | 00.14524.101040                                     |
| <b>GENERAL</b>                               |   |   |
| Measuring principle:                         | Hall Sensor Array, non-contact  |   |
| Range of application                         | temperature -40...+70 °C heated*; wind speed max. gusts 100 m/s;<br>humidity 0...100 % r. h.  |   |
| Supply voltage                               | 24 VDC (20...28 VDC); 18 W heating; max. 800 mA. The heating within the sensor head prevents blocking of the moving parts under most climatological conditions. |   |
| Housing                                      | seawater resistant aluminum; IP 65 in vertical position of use;<br>M12 cable plug connection; stainless steel nut and lock washer                               |   |
| Dimensions                                   | see dimensional drawings  |   |
| Scope of delivery                            | sensor; user manual   |   |
|  | PRO-WEA Wind direction sensor   | PRO-WEA Wind speed sensor                           |
| Measuring element                            | wind vane, dimensionally stable;<br>Aluminum specially coated   | three-armed cup rotor;<br>Aluminum specially coated |
| Measuring range                              | 0...360°  | 0.5...60 m/s  |
| Accuracy                                     | ± 2°  | ± 0.3 m/s ≤ 10 m/s; ± 0.5 m/s...60 m/s              |
| Resolution                                   | < 1°  | < 0.1 m/s   |
| Starting value                               | < 0.5 m/s   | < 0.5 m/s   |
| Output                                       | 4...20 mA = 0...360°  | 4...20 mA = 0...60 m/s                              |
| Update rate                                  | 4 Hz (For the 4...20 mA output, the maximum load of 600 Ohm must not be exceeded).  |   |
| Weight                                       | 0.4 kg  | 0.35 kg   |
| <b>ACCESSORIES (please order separately)</b> |   |   |
| ID 32.14567.060000                           | Sensor cable with plug connection; length: 12 m   |   |
| ID 32.14627.010000                           | Traverse; sensor distance: 75 cm  |   |
| ID 32.14567.008000                           | Mast adapter; diameter: 50 mm   |   |
| ID 32.14565.019000                           | Lightning rod   |   |



\*) In case of possible icing and ice formation on the movable sensor measuring element, the function is reduced for the time of icing.