



USER MANUAL

INDUSTRY

Wind Sensors



Content

Warranty	3
Features of the INDUSTRY wind sensors	3
Initial operation	3
Selecting the place of installation	3
Principles of installation	4
Setting up the north direction for the wind vane	5
Electrical connections	6
Heating	6
Maintenance	6
Wiring diagram	7
Dimensioned drawing wind speed sensor	8
Dimensioned drawing wind direction sensor	9
Disposal	11
Technical data - Cable	11
Technical data - Sensors	12



Warranty

Please note the loss of warranty and non-liability by unauthorized manipulation of the system. You need a written permission of the LAMBRECHT meteo GmbH for changes of system components. These activities must be operated by a qualified technician.

The warranty does not cover:

1. Mechanical damages caused by external impacts (e. g. icefall, rockfall, vandalism).
2. Impacts or damages caused by over-voltages or electromagnetic fields which are beyond the standards and specifications in the technical data.
3. Damages caused by improper handling, e. g. by wrong tools, incorrect installation, incorrect electrical installation (false polarity) etc.
4. Damages which are caused by using the device beyond the specified operation conditions.

Features of the INDUSTRY wind sensors

- INDUSTRY wind sensors for measuring wind direction and wind speed
- More energy savings due to minimal power requirements of the heating system
- Year-round use in all climate zones due to standard variants with integrated, controlled heating and thermally decoupled sensor head
- Low friction, hardly any wear and therefore improved reliability and durability due to double ball bearings of the measuring elements on the rotary axes
- Maximum load-bearing capacity due to the dimensionally stable wind vane made of fiber-reinforced plastic and the break-proof three-armed cup rotor
- Easy installation and maintenance due to cable plug-in connections and screw-in fastening

Initial operation

The wind can be represented by a vector quantity. For a complete description of the wind it is necessary to specify its speed and direction. The two components are subject to spatial and temporal variations; thus, strictly speaking, they are valid only for the site where the measuring instrument is put up. We therefore recommend to select the place of installation very carefully.

Selecting the place of installation

Generally, wind measuring instruments should not measure the specific wind conditions of a limited area, but indicate the typical wind conditions of a wider area. The values measured at different places must be comparable. Thus, when installing the sensor you should make sure the place of installation is not under the lee of great obstacles. The distance between the obstacles and the sensor should be 10 times the height of the obstacles (this corresponds to the definition of an undisturbed terrain).

If there is no *undisturbed terrain*, the sensor must be set up at a height that exceeds the height of the obstacle by at least 5 m.

If the sensor must be installed on a roof top the place of installation must be in the middle of the roof to avoid predominant wind directions.

If you want to measure both wind direction and wind speed, install the sensors at the same measuring point, if possible, and make sure to avoid any mutual influence of the sensors. A wind sensor pair easily meets this requirement since the sensors are set up side by side. Their horizontal distance should be approximately 1.5 m. The two sensors must be staggered vertically so that the lower edge of the upper wind speed sensor is 0.1 to 0.5 m above the upper edge of the lower wind direction sensor.

Principles of installation



Attention! Because the installation takes place in a dangerous height, the assembly personal must follow the rules for prevention of accidents.

I. TRAVERSE WITH BORE (ID-NO. 32.14567.010 000)

At the traverse at each end are bores with a slot and with a \varnothing 30 mm.

1. Remove the lower nut from the sensor.
2. Put a sensor with assembled cable sidewise into the bore.
3. Attach the sensor with the flat side of detached nut from the lower side. Tighten with a suitable tool (wrench size 36), until a twisting safety of the sensor aligned to the north is given.

II. MOUNTING STRAP OR BORE

The material thickness for mounting the sensor between the nuts must not exceed 10 mm.

1. Remove the lower thread nut from the sensor. At sensor type with assembled cable to take off the nut over completely cable length.
2. The sensor with cable-plug connection is led without cable into the bore and fastened by the opposite side with the loose nut as under I.3.
3. The loose nut to be touched now with the flat side first over the cable, in order to fasten the sensor as under I.3.

III. MAST OR PIPE MOUNTING



Make sure the device is easily accessible so that you can set up the north direction for the wind direction sensor and perform any maintenance work. To reach the sensors use a ladder of the appropriate length or a telescoping working platform of the appropriate height.



Ladders or other lifting helps must be absolutely in order and must be guarantee a secure support! Follow the rules for prevention of accidents.

Mount the sensors at the top of grounded tube with an outer diameter \varnothing 48-50 mm. The mast adapter (see accessories) is obligatory.





1. Remove both thread nut from the sensor.
2. The sensor with cable-plug connection is led without cable into the bore and fastened by the opposite side with a loose nut as under I.3.
3. The loose nut to be touched now with the flat side first over the cable, in order to fasten the sensor as under I.3.
4. And finally we recommend to lock the second nut with its plane side ahead against the first nut (see drawing).

You can also use masts that can turn around their vertical axis or masts consisting of individual segments or telescoping masts that you can secure after setting up the north direction.

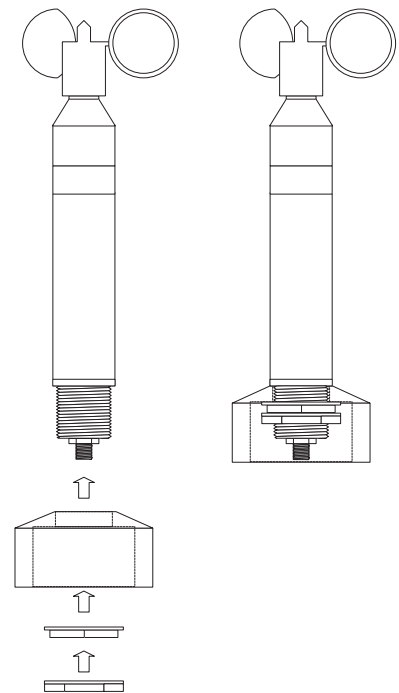
If wind speed and wind direction are measured at the same time, the measurement generally takes place not only at the top of a mast but also at the ends of a cross arm. The arms must stay torsion-free and vibration-proof even at high wind speeds and they must be accessible for you to perform mounting and maintenance work.



- 

When you install the connecting cables make sure not to excessively shorten the cable leading to the connector in the lower part of the sensor casing so that you can later maintain or dismounting the sensor. Put further a cable loop as sensor protection against water under the sensor.
- 

Tip: Install the sensors on ground to the traverse and align you the wind vane parallel to the traverse. You go only then upward, in order to accordingly align the sensors with traverse under assistance of a partner on ground.

Setting up the north direction for the wind vane

For wind direction measurements the north mark on the sensor must be aligned with the geographical north direction. You have to turn the marking exactly over the marking at the sensor shaft. When you have aligned the marks, you may fix the wind vane with e.g. a piece of adhesive tape. When you have fixed the wind vane this way you can locate the reference point by aiming at it over the axis. Now you must turn the sensor casing on the mounting tube until the tip of the wind vane points to the reference point in the north. To set up the sensor's north orientation select a landmark which is as far as possible up north with regard to the final position of the wind direction sensor. The reference point can be selected using a topographical map (1:25000). The exact position of the reference point is determined using an amplitude compass that can be adjusted horizontally on a stand.

- 

Please make sure there is no magnetic deviation of the compass.

Once the wind direction sensor is aligned, you can mount it as described under "Mounting". The adhesive strips must be removed. A functional test on three directions offset by 90° is recommended. If the local conditions do not allow the reference point to be set up in the north direction, the procedure can be applied analogously to a southern reference point. Note that the north mark on the sensor then does not point to the reference point, but in the opposite direction.

Electrical connections

INDUSTRY wind sensors are connected to a data measuring system via the open cable end. The sensors have a cable plug connection to the 12 m cable.

The connecting cable is suitably led along the mast between the data evaluation device (indicating instrument or data acquisition system) and the sensor. The cable must be fastened using appropriate cable ties (their length depends on the mast diameter).



Tip: Lead the cable in a wide curve from the mast to the bottom of the casing so that you can later easily dismount the cable.

Please make sure the cable is protected from humidity on the side of the data processing system. Generally, Pg sockets that use a rubber joint to prevent humidity from penetrating into the terminal box of the data processing system provide sufficient protection.



Example: Cable run by an EMC fair Pg-socket

Alternatively the lead can be laid also completely in the pipes of a mast, if the mast is accordingly prepared.



To reduce the risk of inductive interference the sensor must be properly grounded (screening on both sides).

Heating

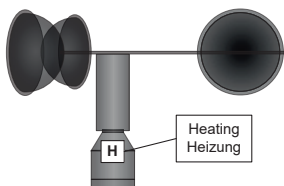

The sensor disposes of an electronically controlled 18 W heating within the sensor head. The heating is supplied together with the sensor electronics. Under most climatological conditions the heating prevents blocking of the moving sensor parts (see illustration). The cup rotor or the wind vane are not heated. In case of icing or formation of ice at the moving sensor element the function is restricted for the period of icing.

Maintenance

The sensor design permits long periods of maintenance-free operation. We therefore recommend a regular visual verification of the north setup of the wind direction sensor as well as a sensor calibration of both sensor types every two years. With problems, which cannot solve you, do not hesitate to contact our LAMBRECHT meteo service under:

Tel.: +49-(0)551-4958-0

E-mail: support@lambrecht.net



Wiring diagram

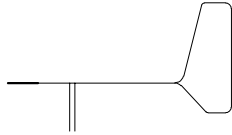

Windflügel für Windrichtung
vane for wind direction



Schalenstern für Windgeschwindigkeit
cup rotor for wind speed

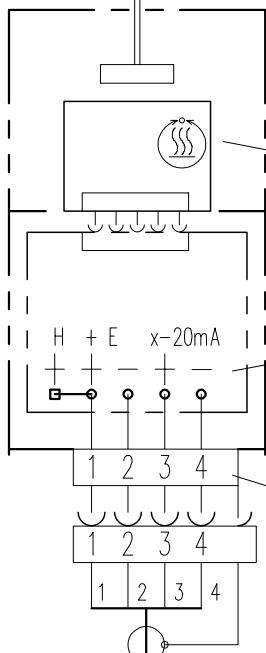

Heizung,
elektronisch geregelt
heating,
electronically controlled

Elektronikplatine
electronic card

4pol.
Steckverbindung
plug connection

PUR/PVC sw, geschirmt
4x0,34
32.14567.060000 (12m)

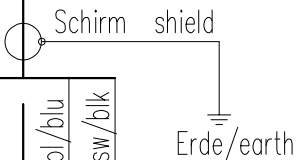

PUR/PVC colorcode	
1	br - brn
2	ws - wht
3	bl - blu
4	sw - blk

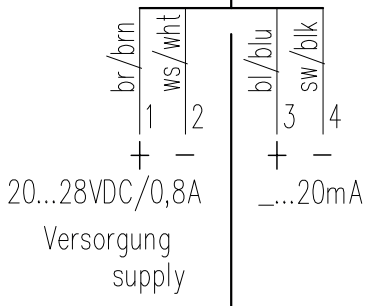

mit Steckverbindung with plug connector	
Windrichtung wind direction	Ausgang/output
No. 00.14567.100000	0...20mA = 0...360°
No. 00.14567.100040	4...20mA = 0...360°
Windgeschwindigkeit wind speed	Ausgang/output
No. 00.14577.100000	0...20mA = 0...50m/s
No. 00.14577.100040	4...20mA = 0...50m/s

Dimensioned drawing wind speed sensor

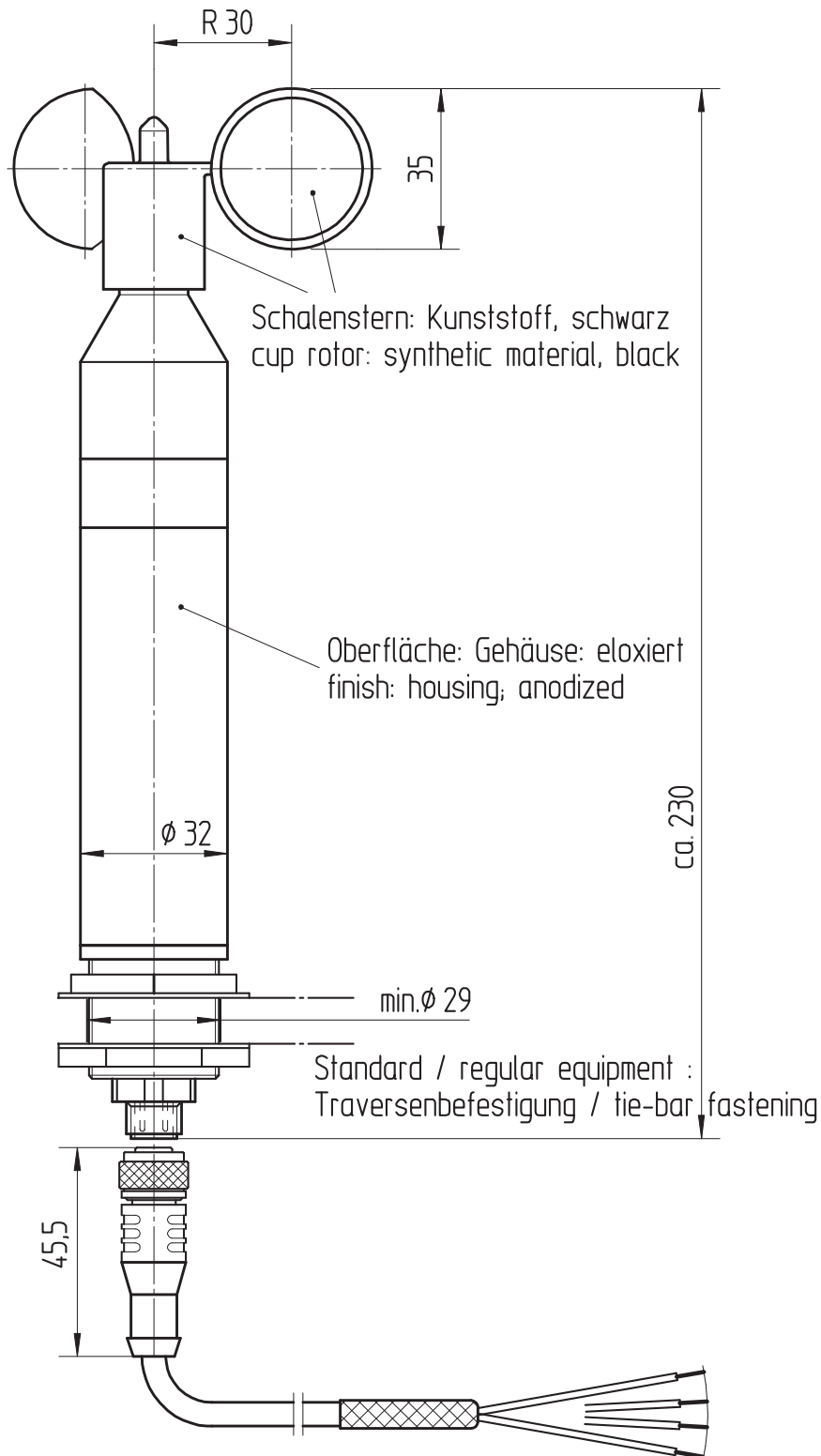

Dimensioned drawing wind direction sensor

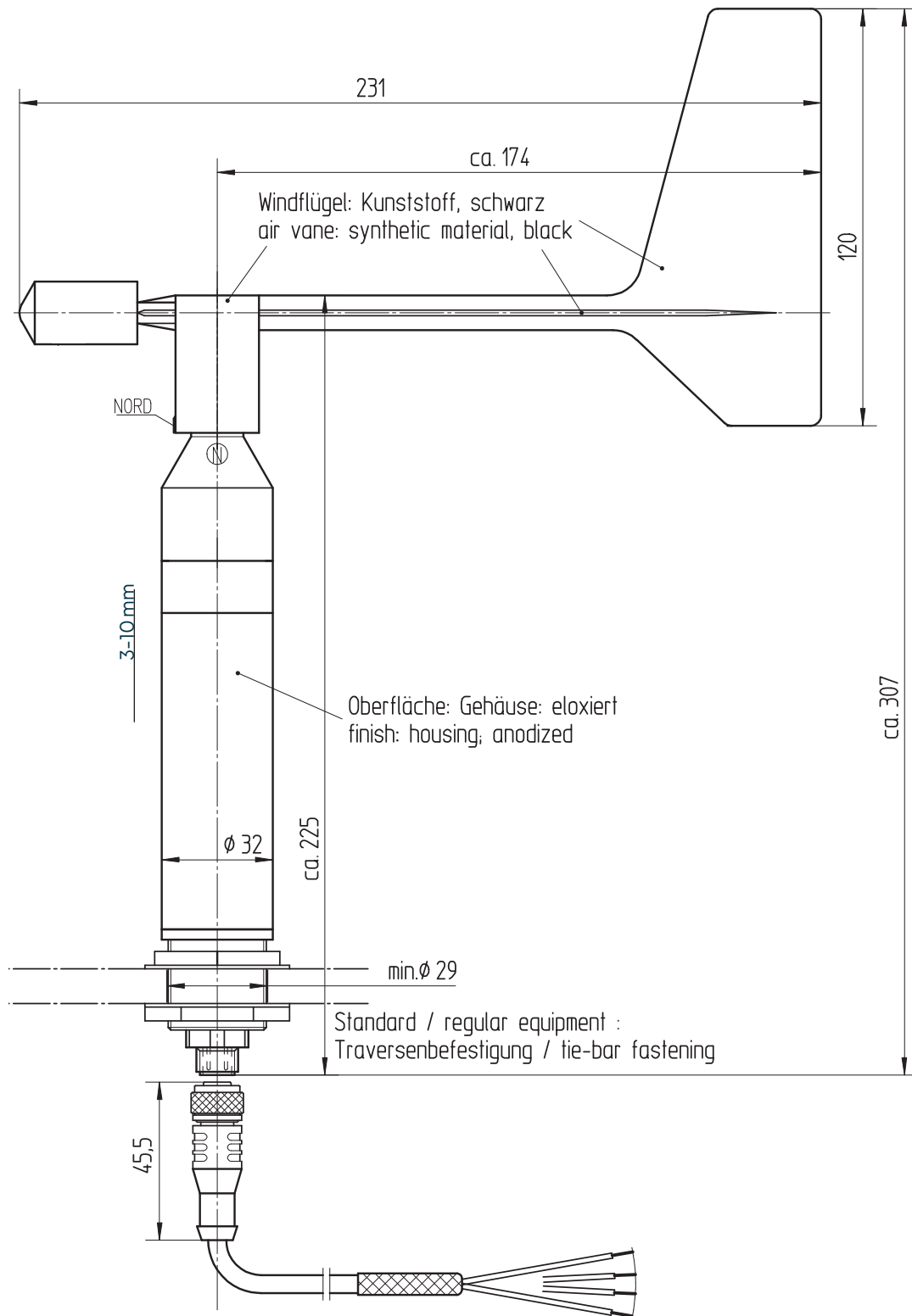

ACCESSORIES (OPTIONAL):

Traverse

IdNo. 32.14567.010 000

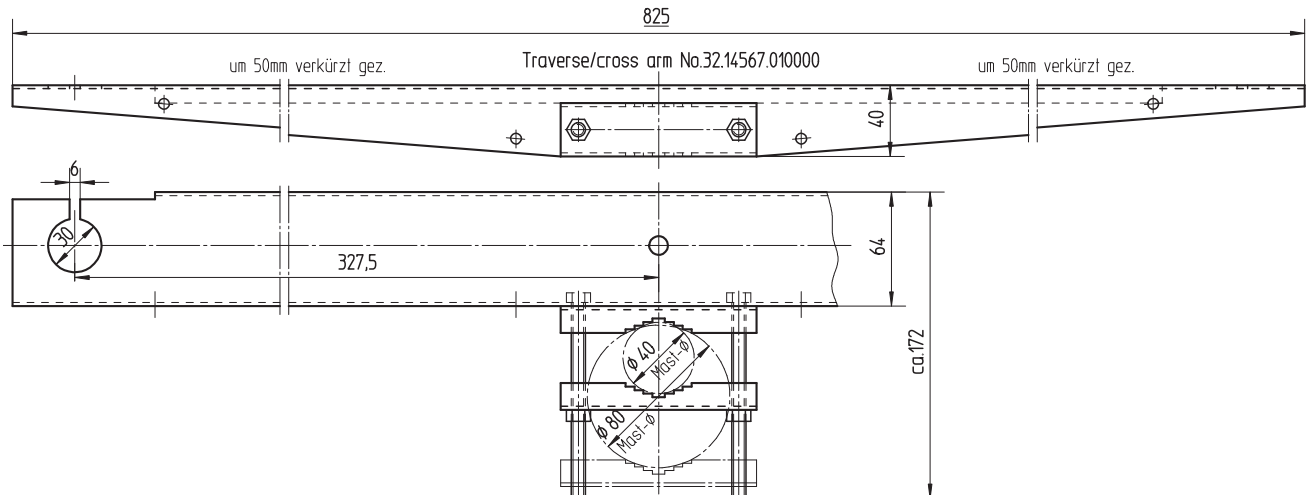

Mast adapter

IdNo. 32.14567.006 000

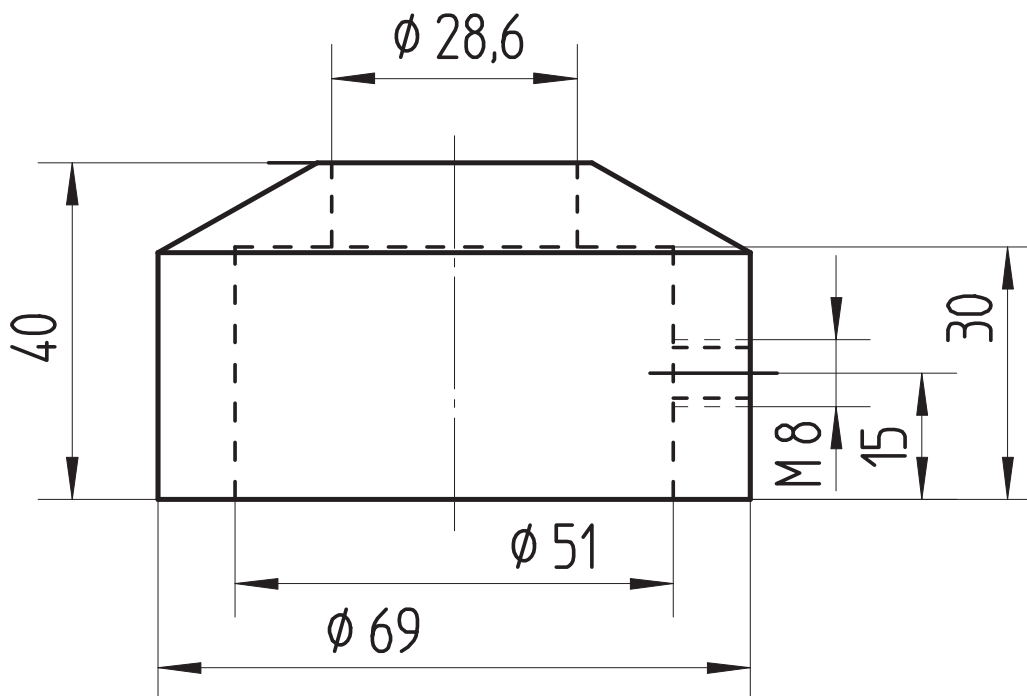

Disposal

LAMBRECHT meteo GmbH is listed and registered at the Stiftung Elektro-Altgeräte Register ear under:

WEEE-Reg.-Nr. DE 45445814

In the category of monitoring and control instruments, device type: "Monitoring and control instruments for exclusively commercial use".

Within the EU



The device has to be disposed according to the European Directives 2002/96/EC and 2003/108/EC (Waste Electrical and Electronic Equipment). Do not dispose the old device in the household waste! For an environmentally friendly recycling and disposal of your old device, contact a certified disposal company for electronic waste.

Outside the EU

Please follow the regulations in your country regarding the appropriate disposal of waste electronic equipment.

Technical data - Cable

ID 32.14567.060000 - Sensor cable with plug connection, length: 12 m

Flame resistance of the cable: acc. to UL Style 20549

DIMENSIONED DRAWING

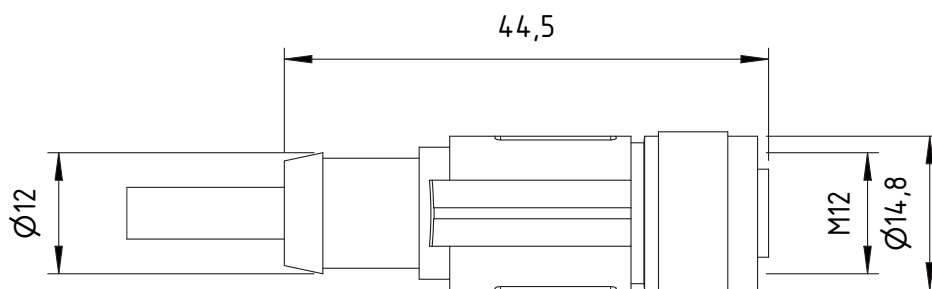

Technical data - Sensors

	INDUSTRY Wind direction sensor	INDUSTRY Wind speed sensor
ID	00.14567.100040 (4...20 mA)	00.14577.100040 (4...20 mA)
GENERAL		
Measuring principle	Hall Sensor Array, non-contact	
Range of application	temperature -30...+70 °C heated*; wind speed 0...60 m/s	
Heating	18 W heating; electronically controlled. The heating in the sensor head prevents blocking of the moving parts under most climatic conditions	
Supply voltage	24 VDC (20...28 VDC); maximal 800 mA	
Housing	seawater-resistant Aluminium; anodized; IP 55; shaft Ø 32 mm with black ring of plastics for thermal isolation (when heated); for mounting-bore Ø 30 mm at maximal 10 mm material thickness	
Dimensions	see dimensioned drawings	
Scope of delivery	1 sensor; user manual	
For connection to (order separately)	data processing system, e. g. Ser[LOG]; power supplies; user-specific evaluation systems	
PARAMETER		
	INDUSTRY Wind direction sensor	INDUSTRY Wind speed sensor
Measuring element	blade vane, dimensionally stable; fiber-reinforced plastic	three-armed cup rotor; break-proof plastic
Measuring range	0...360°	0.7...50 m/s
Accuracy	± 2°	< ± 2 % FS
Resolution	2°	< 0.02 m/s
Starting value	< 0.7 m/s	< 0.7 m/s
Output	4...20 mA = 0...360°; max. load 600 Ω	4...20 mA = 0...50 m/s; max. load 600 Ω; start compensated
Weight	0.35 kg	0.25 kg
ACCESSORIES (please order separately)		
ID 32.14567.060000	Sensor cable with plug connection, length: 12 m	



*) In case of possible icing and ice formation on the movable sensor measuring element, the function is reduced for the time of icing.

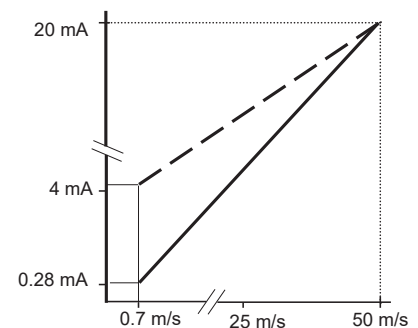

Signal characteristic