

## HLX94/95

### Industrial Grade High Accuracy Thermal Mass Flow Transmitter

Suitable for harsh environments, industrial processes flow monitoring or slightly corrosion compressed air



## | Features |

- IP67 Rugged aluminum alloy case, fit in variety harsh environment
- Easy to install, high accuracy, long-term stability
- Switchable physical quantities : m/s, ft/s, Nm<sup>3</sup>/h, Nm/s, L/min, m<sup>3</sup>/min (Air velocity & volume)
- LCD Display of air velocity and temperature
- LCD Display of cumulative flow : m<sup>3</sup>, L (Option)

## | Introduction |

HLX94/95 Hot wire thermal air velocity transmitter working at a constant Temp.

using King's law heat balance equation for:

$e$  : Sensor voltage output(V)

$a'$  : Zero output of constant temperature hot wire anemometer, Can use CTA circuit as temperature compensation

$$e^2 = a' + b'v^n$$

$b'$  : Sensitivity of the sensor, related to the operating temperature

$v$  : Fluid flow rate

$n$  : 0.45 ... 0.5(Standard)

Can be calculated from the formula characteristic curve of constant Temp. hot wire anemometer, special three PT probe and full metal housing design, high accuracy, suitable for a variety of pipe diameters, widely used in industrial fields.

## | Applications |

Exhaust gas removal / Dust environment / Slightly corrosive environment / Burner feeder / Biotechnology industry / Factory building air intake / Exhaust calculation

## Specification

### Input

Input type	Pt20 / Pt300 (Air velocity) / Pt1000 (Temp.)
Measuring range	0 ... 120 Nm/s
	N : Working condition (Definition : 20°C at 1013 hPa)
	Units can be converted Nm/s (Flow rate) or Nm <sup>3</sup> /h(Flow)(Option) or m <sup>3</sup> (Cumulative flow)(Option)
Minimum initial value	0.15 Nm/s

### Output

Installation angle effect	<3% of the measured value
(When the installation angle<10°)	
Signal	4 ... 20 mA / 0 ... 10 V / RS-485 / Impulse
Preset output	Out1 : Air velocity ; Out2 : Impulse
Impulse range (1 ... 500 Hz)	(1)1 ... 500 Hz : 4 ... 20 mA
	(2)1 ... 500 Hz : 0 ... 10 V
Signal connection	3-wire
Warm-up time	<60 sec
Reaction time	t90<5 sec
Display type	LCD Module with back light, double-row
	(Up air velocity, down temperature(Default: 0 ... 120°C))
Load resistance	Current output : ≤500 Ω
	Voltage output : ≥100 KΩ

### Accuracy

Accuracy	±1.5% F.S. (Option ±1%)
Temp. influence	0.1% / °C
Repeatability	0.5%

### Electrical

Power supply	DC 24 V±10%
Current consumption	<0.3 A
Overvoltage protection	DC : <40 V
Electrical connections	M12 connector / M16 metal cable gland

### Environmental

Measuring medium	Air
Operating Temp.	-20 ... +60°C
Operating Humid.	0 ... 95%RH(Non-condensing)
Probe operating Temp.	0 ... 120°C / Option:200°C
	(Increasing operating temperature will affect air velocity error)
Storage Temp.	-20 ... +60°C
Storage Humid.	0 ... 95%RH(Non-condensing)
Probe pressure	16 bar

### Installation

Fixed seat	1/2"PT movable thread
Installation	Duct type
	Remote type

### Protection

IP rating	IP67(Probe) ; IP65(Housing)
Electrical protection	<input checked="" type="checkbox"/> Reverse polarity <input checked="" type="checkbox"/> Over-voltage <input checked="" type="checkbox"/> Short-circuit

### Certification

Certification	CE
---------------	----

### Material

Housing	Aluminum alloy
Probe	SS304 ( Option SUS316 )
Weight	FTM94 : 720 g
	FTM95 : 832 g

\*Please make sure the product and the device which connect with RS-485 are on common ground, avoid damaged product.

## 3-Cycle curve

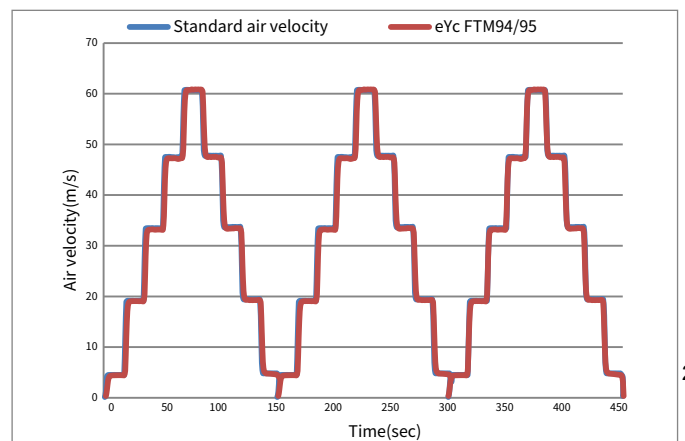
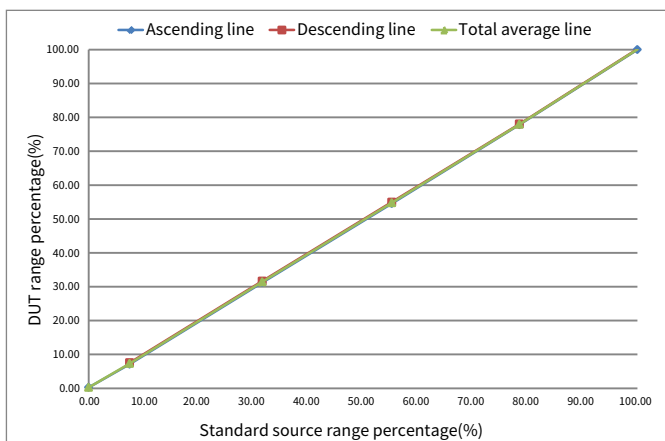

## Dimension | Unit : mm

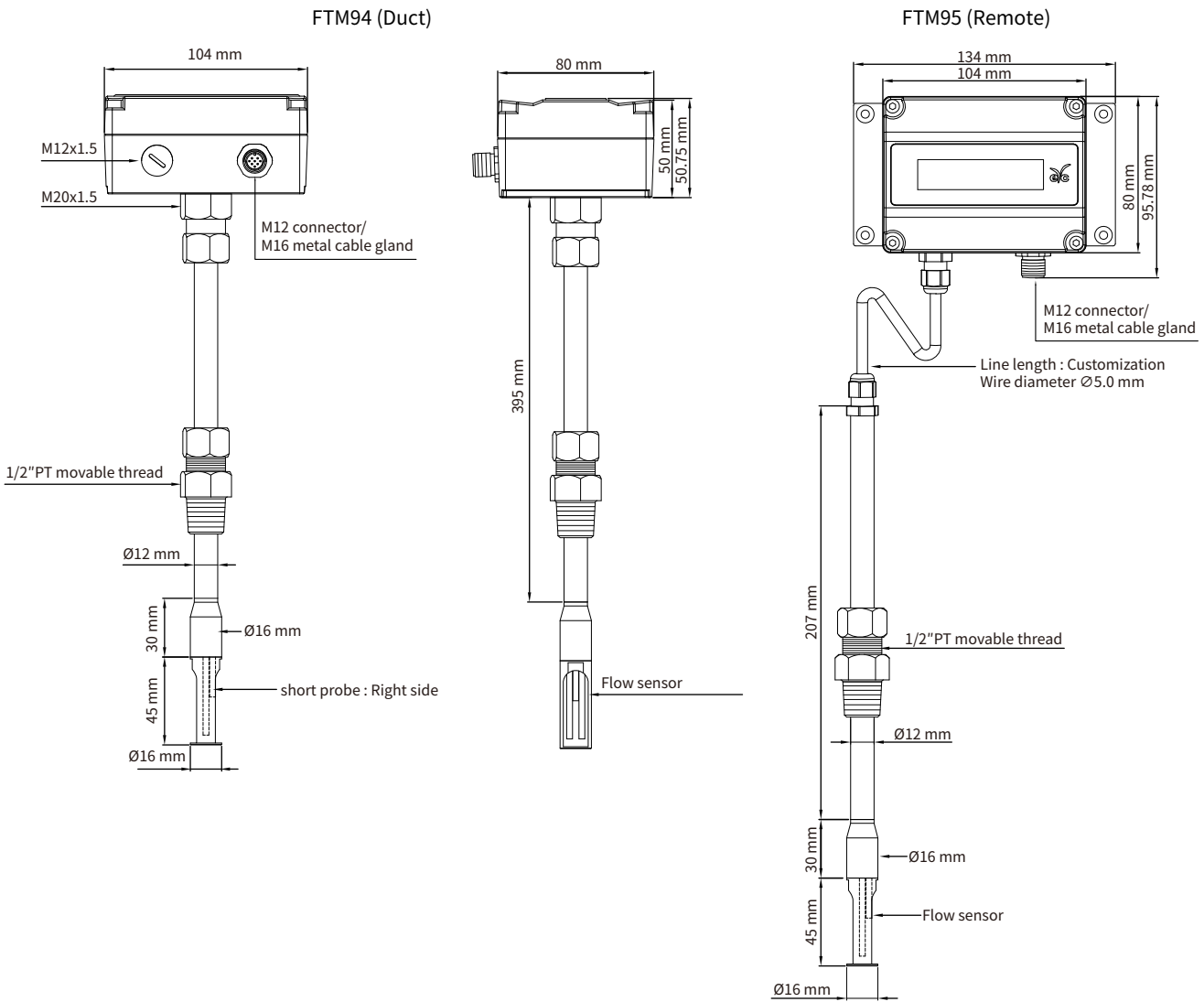

## Electrical Connector | Unit : mm

M type :  
M12 connector(RS-485+analog)

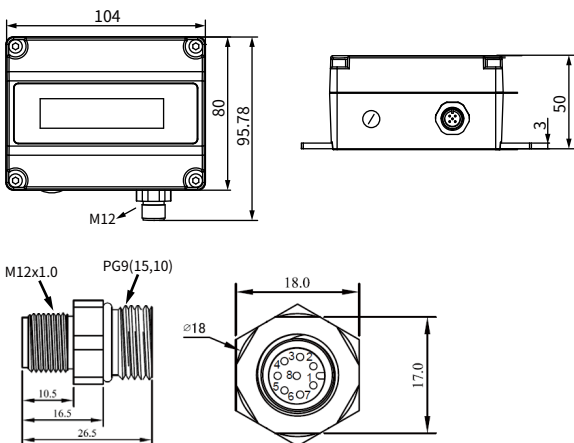

N type :  
M16 metal cable gland(RS-485+analog)

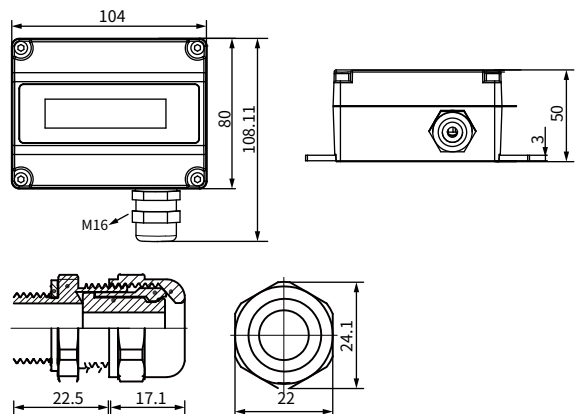

## | Analog & Impulse Diagram |

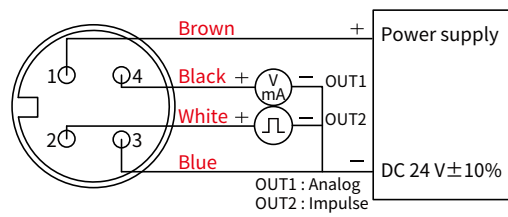
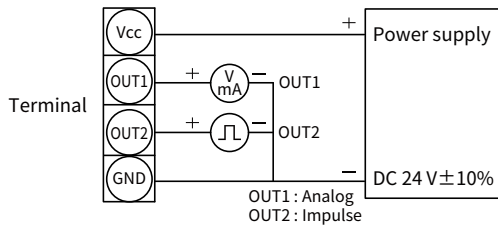

## | RS-485 Diagram |

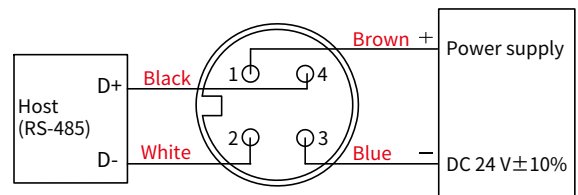
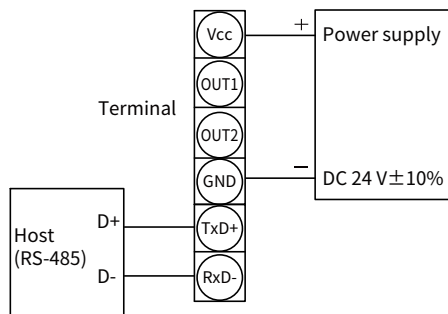

## | Analog+RS-485 & Impulse Diagram |

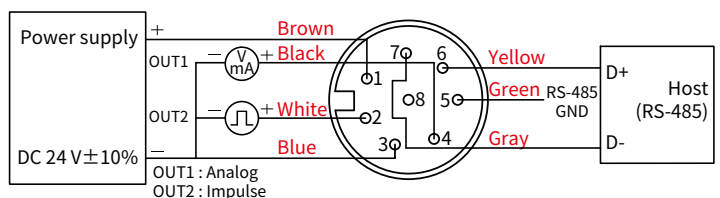
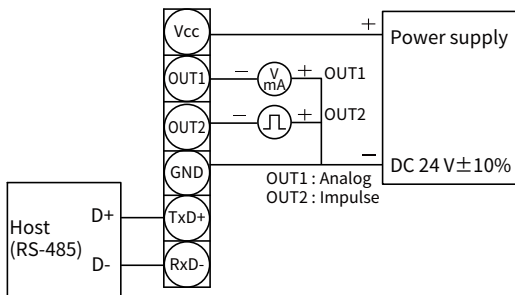

## | Hot-wire measurement principle |

The thermal measuring principle abstraction of heat from a heated body by an enveloping gas flow (Hot-film Anemometer)

$T$  between  $R_h$  and  $R_t$  = constant

The loss of heat depends on the number of molecules that collide with  $R_h$

$m$  : Mass flow

$I_h$  : Heating current

$R_h$  : Platinum thin-film resistor – electrically heated

$R_t$  : Platinum thin-film resistor – gas temperature

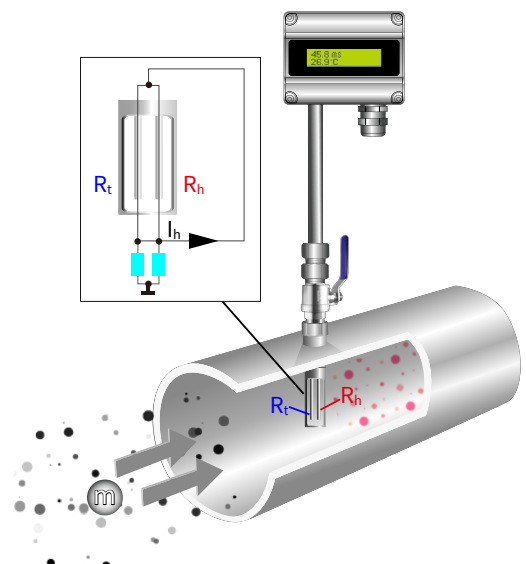

## | Ordering Guide |

HLX	Installation	—	Measuring range	Output	Modbus	—	Cable	Display	Option
	94	02	1	1	X	D	N		
	94 : Duct type 95 : Remote type	02 : 20 Nm/s 04 : 40 Nm/s 06 : 60 Nm/s 09 : 90 Nm/s 12 : 120 Nm/s	1 : 4 ... 20 mA+impulse 2 : 0 ... 10 V+impulse 3 : No	0 : No 1 : RS-485	2 : 2 m cable 5 : 5 m cable W : Other lengths (Max. length : 5 m) X : No	D : LCD display N : No	M : M12 connector with 2 m cable N : M16 metal cable gland W : Other request / Cumulative flow		

## | Additional Option Test Report | For more detailed information please contact us.

### ■ ILAC / TAF

Calibration Laboratory - ( ILAC / TAF ) Test report.  
(TAF accreditation : 3032, complying with ISO / IEC 17025 ) TAF has mutual recognition arrangement with ILAC MRA

Project	Measurand level or range
Air velocity transmitter	0.2 m/s ... 60 m/s

### ■ ISO 9001

Project	Measurand level or range
Air velocity / Air volume	Air velocity : $\leq 120$ m/s
	Air volume : 0.5 m <sup>3</sup> /h ... 1000 m <sup>3</sup> /h