



USER MANUAL

# 16131.5

First Class Pyranometer



## Safety instructions and Warranty



Putting more than 12 Volt across the sensor wiring of 00.16131.501000 can lead to permanent damage to the sensor.



Putting more than 30 Volt across the sensor wiring of the main power supply can lead to permanent damage to the sensor.



For proper instrument grounding: use 16131.5 with its original factory-made cable.



Using the same Modbus address for more than one device will lead to irregular behavior of the entire network.



Disconnect power while performing service or maintenance.



Keep the voltage on the RS-485 data wiring of 00.16131.501030 between -7 and +12 V to avoid permanent damage.

This system is designed according to the state-of-the-art accepted safety regulations. However, please note the following rules:

1. Before putting it into operation please read all respective manuals!
2. Please observe all internal and state-specific guidelines and/or rules for the prevention of accidents. If necessary, ask your responsible safety representative.
3. Use the system only as described in the manual.
4. Always have the manual at hand at the installation site.
5. Use the system within the specified operating condition. Eliminate influences, which might impair the safety.
6. Prevent the ingress of unwanted liquids into the devices.

**Please note the loss that unauthorized manipulation of the system shall result in the loss of warranty and non-liability. Changes to system components require express written permission from LAMBRECHT meteo GmbH. These activities must be performed by a qualified technician.**

**The warranty does not cover:**

1. Mechanical damage caused by external impacts (e.g. icefall, rockfall, vandalism).
2. Impacts or damage caused by over-voltage or electromagnetic fields which are beyond the standards and specifications of the device.
3. Damage caused by improper handling, e.g. by using the wrong tools, incorrect installation, incorrect electrical installation (incorrect polarity) etc.
4. Damage caused by using the device outside the specified operation conditions.

Modbus® is a registered trademark of Schneider Electric, licensed to the Modbus Organization, Inc.

# Contents

<b>Safety instructions and Warranty</b>	<b>2</b>
<b>Contents</b>	<b>3</b>
<b>Introduction</b>	<b>4</b>
<b>1 Ordering and checking at delivery</b>	<b>5</b>
1.1 Ordering 16131.5	5
1.2 Included items	5
1.3 Quick instrument check	5
<b>2 Instrument schematic</b>	<b>6</b>
<b>3 Specifications of 16131.5</b>	<b>8</b>
3.1 Specifications of 16131.5	8
3.2 Dimensions of 16131.5	11
<b>4 Installation of 16131.5</b>	<b>12</b>
4.1 Site selection and installation	12
4.2 Installation of the sun screen	13
4.3 Installation of pyranometer	14
4.4 Electrical connection of active 16131.5 series: wiring diagram	15
4.5 Electrical connection of passive 16131.5: wiring diagram	16
4.6 Grounding and use of the shield	16
4.7 Using heater of 00.16131.501030 and 00.16131.0501000	16
4.8 Using 00.16131.501040's analogue 4 to 20 mA output	17
4.9 Data acquisition requirements for using 00.16131.501000's millivolt output	18
4.10 Connecting to an RS-485 network	19
<b>5 Communication with 16131.5</b>	<b>20</b>
5.1 Modbus-protocol	20
5.2 Data encoding	20
5.3 Device-address	20
5.4 Standard configuration - default	20
5.5 Modbus command set	21
5.6 Measured value and parameter register	21
5.7 Additional value registers (Service)	21
5.8 Sensor parameters / configuration-parameters	22
5.9 Network communication: getting started	23
5.10 Adapting the Modbus address and communication settings	23
<b>6 Maintenance and trouble shooting</b>	<b>24</b>
6.1 Recommended maintenance and quality assurance	24
6.2 Trouble shooting	25
<b>7 Appendices</b>	<b>27</b>
7.1 LAMBRECHT meteo – Auto-configuration	27
7.2 EU declaration of conformity	30

# Introduction

16131.5 digital pyranometer series is a range of high-accuracy digital solar radiation sensors. It is “first class” according to the WMO guide and ISO 9060:1990 standard and “Spectrally Flat Class B” in the 2018 revision. Version 00.16131.501030, equipped with an on-board heater, is compliant in its standard configuration with the requirements for “Class B” PV monitoring systems of the IEC 61724-1:2017 standard.

The 16131.5 measures the solar radiation received by a plane surface, in  $W/m^2$ , from a  $180^\circ$  field of view angle. Various outputs are available, both digital and analogue, for ease of integration.

- Version 00.16131.501030: digital sensor with Modbus over RS-485 output and heater
- Version 00.16131.501040: digital sensor with Modbus over TTL (on request) and analogue 4-20 mA output (without heater)
- Version 00.16131.501000: passive sensor with analogue millivolt output and heater

## Benefits of the 16131.5 series:

- best measurement accuracy in first class
- improved response time
- with 00.16131.501030's on-board heater: compliant with IEC 61724-1 Class B in its standard configuration

Using the analogue version 00.16131.501000 is easy: the pyranometer can be connected directly to commonly used data logging systems. The irradiance in  $W/m^2$  is calculated by dividing the signal output, a small voltage, by the sensitivity. This sensitivity is provided with 00.16134.501000 on its calibration certificate.

The central equation governing 00.16131.501000 is:  $E = U/S$

U: Voltage output in V

S: Sensitivity in  $V/(W/m^2)$

E: Solar irradiance in  $W/m^2$

## Suggested use

Suggested use for 16131.5:

- PV system performance monitoring
- general solar resource monitoring
- indoor simulated solar testing
- meteorological networks

# 1 Ordering and checking at delivery

## 1.1 Ordering 16131.5

Id-No. for standard configurations 16131.5:

### Version 00.16131.501030:

ISO 9060 first class pyranometer sensor with Modbus over RS-485 and heater

### Version 00.16131.501040:

ISO 9060 first class pyranometer sensor with 4 to 20 mA output without heater

### Version 00.16131.501000:

ISO 9060 first class pyranometer sensor with passive analogue millivolt output and heater

Common options / accessories are:

- |   |                        |
|---|------------------------|
| • cable 10 m, M12 plug connector, 5-pin | Id-No. 32.14581.060000 |
| • cable 15 m, M12 plug connector. 5-pin | Id-No. 32.05005.001500 |

Suitable data loggers:

- |            |                        |
|------------|------------------------|
| • met[LOG] | Id-No. 00.95800.010000 |
| • Ser[LOG] | Id-No. 00.95770.000000 |

## 1.2 Included items

Arriving at the customer, the delivery should include:

- pyranometer 16131.5
- sun screen
- cable of the length as ordered
- product certificate matching the instrument serial number, including:
  - calibration certificate
- any other options as ordered

Please store the certificates in a safe place.

## 1.3 Quick instrument check

1. At power-ON the signal may have a temporary output level different from zero; an offset. Let this offset settle down; it is a normal part of the power-ON procedure.
2. Check if the sensor reacts to light: expose the sensor to a strong light source, for instance a 100 W light bulb at 0.1 m distance. The signal should read  $> 100 \text{ W/m}^2$  now. Darken the sensor either by putting something over it or switching off the light. The instrument irradiance output should go down and within one minute approach  $0 \text{ W/m}^2$ .
3. Inspect the instrument for any damage.
4. Check the instrument serial number as indicated by the label on the instrument against the certificates provided with the instrument.

## 2 Instrument schematic

16131.5's scientific name is pyranometer. A pyranometer measures the solar radiation received by a plane surface from a 180° field of view angle. This quantity, expressed in  $W/m^2$ , is called "hemispherical" solar radiation.

The solar radiation spectrum extends roughly from 285 to  $3000 \times 10^{-9}$  m. By definition a pyranometer should cover that spectral range with a spectral selectivity that is as "flat" as possible.

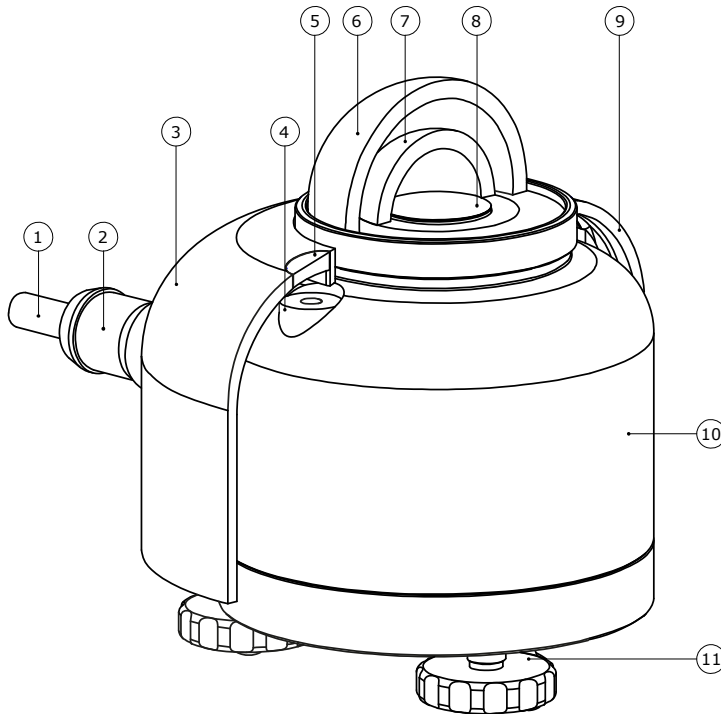

**Figure 2.0.1** Overview of 16131.5:

- (1) cable
- (2) connector
- (3) sun screen
- (4) bubble level
- (5) bubble level window
- (6) outer dome
- (7) inner dome
- (8) thermal sensor with black coating
- (9) quick release system of sun screen
- (10) instrument body
- (11) levelling feet

The 16131.5 pyranometer series employs a state-of-the-art thermopile sensor with black coated surface, two domes and an anodized aluminum body.

Version 00.16131.501030 offers irradiance in  $W/m^2$  as a digital output. It must be used in combination with a suitable power supply and a data acquisition system which uses the Modbus communication protocol over RS-485. To reduce the effect of dew deposition and frost on the outer dome surface, 00.16131.501030 has a built-in heater. The heater is coupled to the sensor body. Heating a pyrometer can generate additional irradiance offset signals, therefore it is recommended to activate the heater

only during night-time. Combining a heater with external ventilation makes these heating offsets very low.

Version 00.16131.501040 offers irradiance in  $W/m^2$  as a 4-20 mA output. It must be used in combination with suitable power supply and a data acquisition system which is capable of handling a 4-20 mA current loop signal.

Version 00.16131.501000 offers irradiance in  $W/m^2$  as an analogue millivolt output. It is a passive sensor and does not need a power supply. It can be connected directly to commonly used data logging systems. To reduce the effect of dew deposition and frost on the outer dome surface, 00.16131.501000 has a built-in heater. The heater is coupled to the sensor body. Heating a pyrometer can generate additional irradiance offset signals, therefore it is recommended to activate the heater only during night-time. Combining a heater with external ventilation makes these heating offsets very low.

The irradiance in  $W/m^2$  is calculated by dividing the 00.16131.501000 output, a small voltage, by the sensitivity. This sensitivity is e.g. provided on its calibration certificate.

The central equation governing 00.16131.501000 is:

$$E = U/S$$

U: Voltage output in V

S: Sensitivity in  $V/(W/m^2)$

E: Solar irradiance in  $W/m^2$

## 3 Specifications of 16131.5

### 3.1 Specifications of 16131.5

16131.5 measures solar radiation received by a plane surface from a 180° field of view angle. This quantity, expressed in  $\text{W/m}^2$ , is called “hemispherical” solar radiation.

The instrument is classified according to ISO 9060 and should be used in accordance with the recommended practices of ISO, IEC, WMO and ASTM.

**Table 3.1.1** Specifications of 16131.5

<b>16131.5 MEASUREMENT SPECIFICATIONS:</b>	
ISO classification (ISO 9060:1990)	First class pyranometer
WMO performance level (WMO-No. 8, seventh edition 2008)	good quality pyranometer
Response time (95 %)	< 10 s
Zero offset a (response to 200 $\text{W/m}^2$ net thermal radiation)	5 $\text{W/m}^2$ unventilated
Zero offset b (response to 5 K/h change in ambient temperature)	< 4 $\text{W/m}^2$
Non-stability	< 1 % change per year
Non-linearity	< 1 % (100 to 1000 $\text{W/m}^2$ )
Directional response	< 20 $\text{W/m}^2$
Spectral selectivity	< 3 % (0.35 to 1.5 $\times 10^{-6}$ m)
Temperature response	< 2 % (-30 to +50 °C)
Tilt response	< 2 % (0 to 90 ° at 1000 $\text{W/m}^2$ )
Measurement range	0 to 3000 $\text{W/m}^2$
Zero offset steady state	< 1 $\text{W/m}^2$ (-40 to + 80 °C)
Spectral range (20 % transmission points)	285 to 3000 $\times 10^{-9}$ m

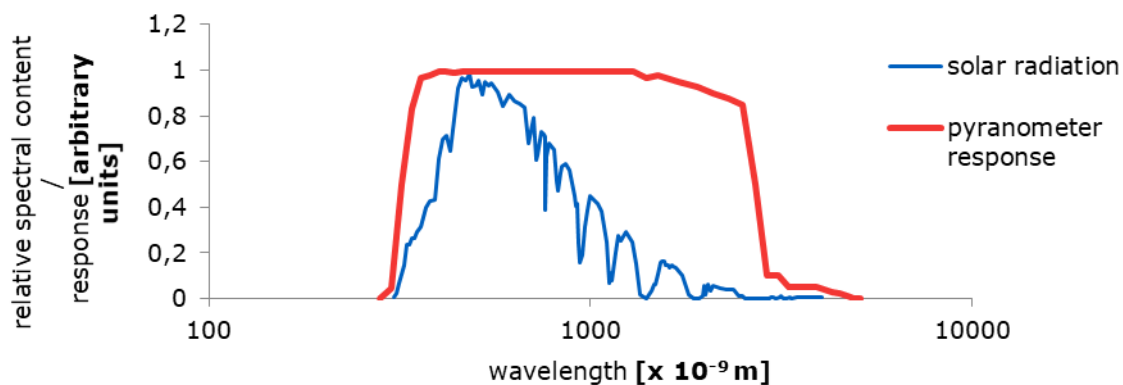

**Figure 3.1.1** Spectral response of the pyranometer compared to the solar spectrum. The pyranometer only cuts off a negligible part of the total solar spectrum.

<b>Measurand</b>	hemispherical solar radiation
Measurand in SI radiometry units	irradiance in $\text{W/m}^2$
Optional measurand	sunshine duration
Field of view angle	180 °
Output definition	running average over 4 measurements, refreshed every 0.1 s
Recommended data request interval	1 s, storing 60 s averages
Temperature range of application	-40 to + 80 °C
<b>IEC 61724-1:2017 COMPLIANCE</b>	
IEC 61724-1:2017 compliance	meets Class B PV monitoring system requirements

<b>16131.5 ADDITIONAL SPECIFICATIONS</b>	
<b>Measurand</b>	Sensor body temperature
Measurand in SI radiometry units	temperature in °C
Temperature sensor	solid state System on Chip (SoC) silicon bandgap temperature sensor
Instrument body temperature accuracy	0.5 °C
Instrument body temperature resolution	$3.9 \times 10^{-3}$ °C
Levelling (see options)	bubble level and adjustable levelling feet are included
Levelling accuracy	< 0.1 ° bubble entirely in ring
Connector type	M12-A, 5-pole, IP67
Mounting	2 x M5 bolt at 46 mm distance on north-south axis
IP protection class	IP67
Net weight including 5m cable	0.65 kg
<b>HEATING (00.16131.501030 and 00.16131.501000 only)</b>	
<b>Heater operation</b>	The heater is not necessarily switched on; recommended operation is to activate the heater when the sun is below the horizon.
<b>Heater voltage</b>	12 VDC
Required heater power	1.5 W at 12 VDC (the heater is not necessarily active)
Heater resistance	95 Ω
Steady state zero offset caused by heating	0 to -8 W/m <sup>2</sup>
<b>CALIBRATION</b>	
Calibration traceability	to WRR
Calibration hierarchy	from WRR through ISO 9846 and ISO 9847, applying a correction to reference conditions
Calibration method	indoor calibration according to ISO 9847, Type IIc
Calibration uncertainty	< 1.8 % (k = 2)
Recommended recalibration interval	2 years
Reference conditions	20 °C, normal incidence solar radiation, horizontal mounting, irradiance level 1000 W/m <sup>2</sup>
Validity of calibration	Based on experience the instrument sensitivity will not change during storage. During use under exposure to solar radiation the instrument “non-stability” specification is applicable.
<b>MEASUREMENT ACCURACY AND RESOLUTION</b>	
Uncertainty of the measurement	statements about the overall measurement uncertainty can only be made on an individual basis.
WMO estimate on achievable accuracy for daily sums	5 % (WMO-No. 8, seventh edition 2008)
WMO estimate on achievable accuracy for hourly sums	8 % (WMO-No. 8, seventh edition 2008)
Irradiance resolution	0.01 W/m <sup>2</sup>
<b>00.16131.501030 – DIGITAL MODBUS RTU (RS-485)</b>	
Digital output	irradiance in W/m <sup>2</sup> instrument body temperature in °C
Rated operating voltage range	5 to 30 VDC (recommended 12 VDC)
Power consumption	< $48 \times 10^{-3}$ W at 12 VDC (unheated)
Heater	included
Communication protocol	Modbus over 2-wire RS-485 half duplex
RS-485 transceiver type	2-wire, non-isolated
Transmission mode	RTU

<b>00.16131.501040 – ANALOGUE 4 TO 20 mA</b>	
4 to 20 mA output	irradiance in W/m <sup>2</sup>
Transmitted range	0 to 1600 W/m <sup>2</sup>
Output signal	4 to 20 x 10 <sup>-3</sup> A
Standard setting (see options)	4 x 10 <sup>-3</sup> A at 0 W/m <sup>2</sup> and 20 x 10 <sup>-3</sup> A at 1600 W/m <sup>2</sup>
Principle of 4 to 20 mA output	2-wire current loop
Rated operating voltage range	5 to 30 VDC (recommended 12 VDC)
Recommended operating voltage	12 VDC
Power consumption	< 240 x 10 <sup>-3</sup> W at 12 VDC
Heating	not included
<b>00.16131.501000 - ANALOGUE mV</b>	
Millivolt (mV) output	irradiance in W/m <sup>2</sup>
Sensitivity range	7 to 15 x 10 <sup>-6</sup> V/(W/m <sup>2</sup> )
Sensitivity (nominal)	10 x 10 <sup>-6</sup> V/(W/m <sup>2</sup> )
Expected voltage output	application under natural solar radiation: -0.1 to +30 x 10 <sup>-3</sup> V
Measurement function / required programming	E = U/S U: Voltage output in V S: Sensitivity in V/(W/m <sup>2</sup> ) E: Solar irradiance in W/m <sup>2</sup>
Irradiance resolution	depends on readout equipment; 7 x 10 <sup>-6</sup> V data logger resolution is sufficient for 1 W/m <sup>2</sup> resolution in irradiance
Required readout	1 differential voltage channel or 1 single ended voltage channel, input resistance > 10 <sup>6</sup> Ω
Sensor resistance range	50 to 150 Ω

### 3.2 Dimensions of 16131.5

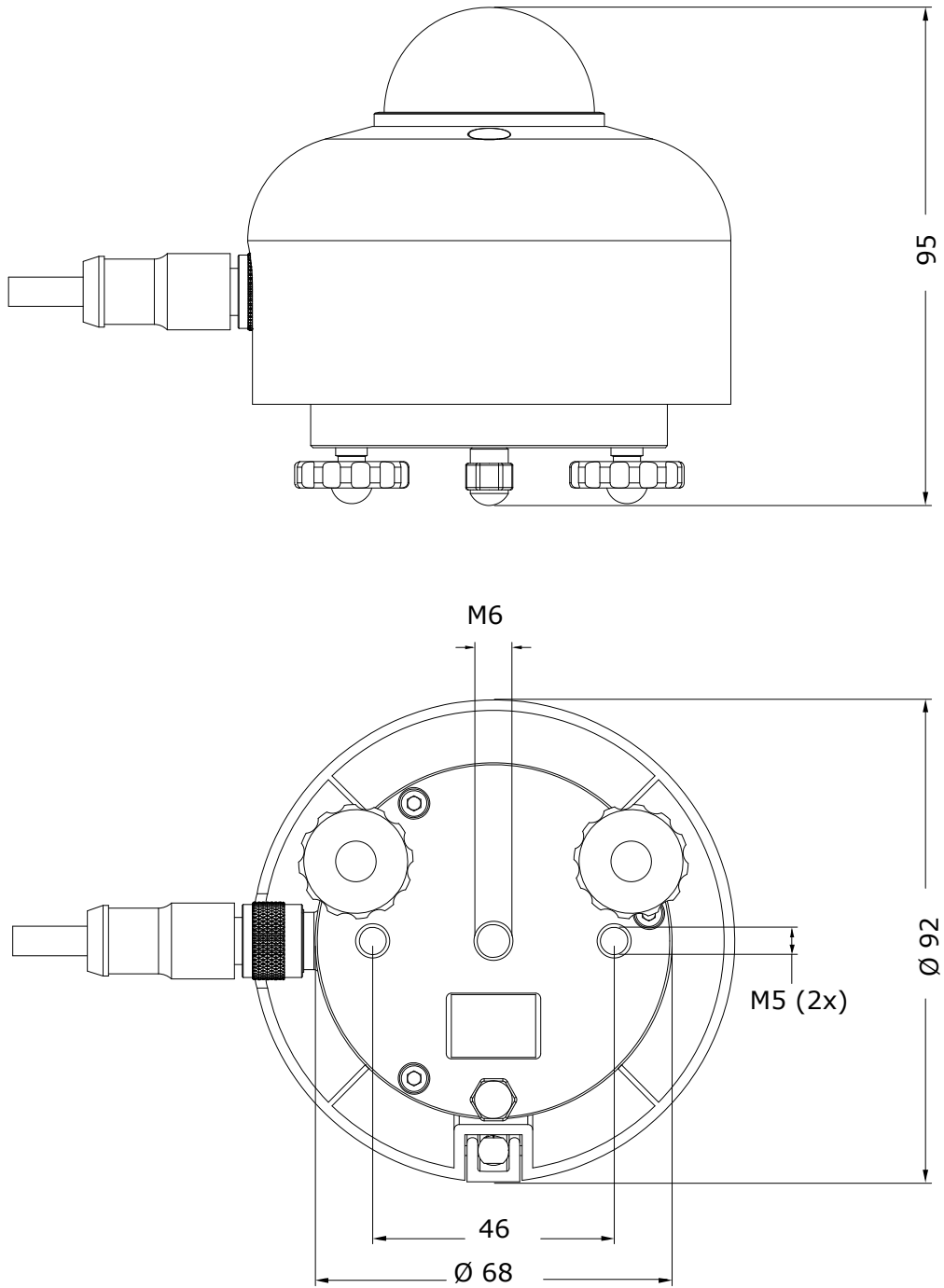

Figure 3.2.1 Dimensions of 16131.5 in  $\times 10^{-3} m$

## 4 Installation of 16131.5

### 4.1 Site selection and installation

**Table 4.1.1** *Recommendations for installation of pyranometers*

Location	The horizon should be as free from obstacles as possible. Ideally, there should be no objects between the course of the sun and the instrument.
Mechanical mounting / thermal insulation	Use connection by bolts to the bottom plate of the instrument. A pyranometer is sensitive to thermal shocks. Do not mount the instrument with the body in direct thermal contact to the mounting plate (so always use the levelling feet also if the mounting is not horizontal), do not mount the instrument on objects that become very hot (black coated metal plates).
Instrument mounting with 2 bolts	2 x M5 bolt at $46 \times 10^{-3}$ m center to center distance on north-south axis, connection from below under the bottom plate of the instrument.
Instrument mounting with one bolt	1 x M6 bolt at the center of the instrument, connection from below under the bottom plate of the instrument.
Performing a representative measurement	The pyranometer measures solar radiation in the plane of the sensor. Some installations require a tilted or inverted position. The sensor bottom plate, parallel to the black sensor surface, should be mounted parallel to the plane of interest. In case a pyranometer is not mounted horizontally or in case the horizon is obstructed, the representativeness of the location becomes an important element of the measurement. See the chapter on uncertainty evaluation.
Levelling	In case of horizontal mounting, use the bubble level and levelling feet. The bubble level is visible and can be inspected at all times.
Tilted installation	For tilted installation, the tilt sensor provides sufficiently accurate measurement. The register "tilt angle" can be used when mounting and levelling the sensor.
Instrument orientation	By convention: with the cable exit pointing to the nearest pole, so the cable exit should point north in the northern hemisphere, south in the southern hemisphere.
Installation height	In case of inverted installation, WMO recommends a distance of 1.5 m between soil surface and sensor (reducing the effect of shadows and in order to obtain good spatial averaging).

## 4.2 Installation of the sun screen

The quick release system of 16131.5's sun screen allows for easy and secure mounting of the sun screen on the sensor. Installation and removal of the connector can be done after removal of the sun screen.

Release sun screen: The system consists of a spring loaded lever opposite the bubble level window of the 16131.5 sun screen. The bottom of the handle can be pulled out gently. Once the handle is pulled out and fully released, as shown in the figure below, the sun screen can be lifted off manually for removal.

Installing the sun screen: pull out the bottom of the quick release system handle so it is fully released, place the screen on 16131.5 and, once it is positioned properly, press the handle of the quick release system until it is locked.



**Figure 4.2.1** 16131.5's sun screen with its quick release system and bubble level window



**Figure 4.2.2** Installation of 16131.5's sun screen

### 4.3 Installation of pyranometer

LAMBRECHT meteo provides several mounting set for the 16131.5 pyranometer.

Id-No. 32.14627.003010	Set for inclined mounting on traverse system 14627
Id-No. 32.14627.003000	Set for horizontal mounting on traverse system 14627
Id-No. 33.14627.012000	Set for wall mounting

The picture below shows the installation of the 16131.5 on the “Set for inclined mounting” as an example. The whole pattern for mounting the 16131.5 is the same for all the sets mentioned above.

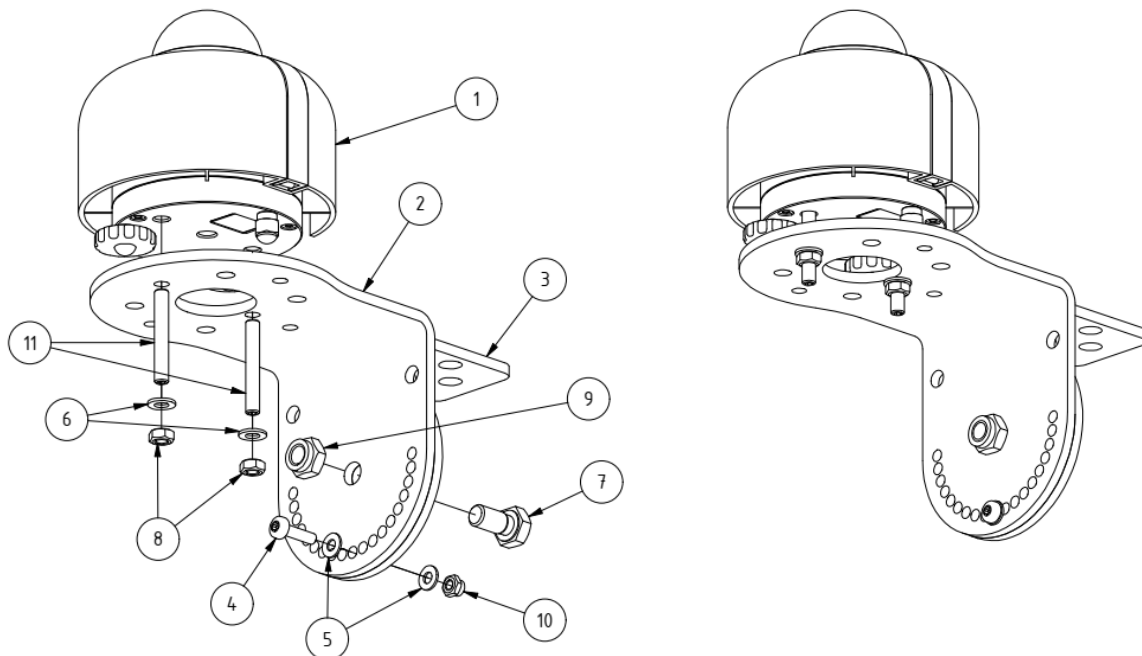

**Figure 4.3.1** Mounting of 16131.5 on Set for inclined mounting on traverse system 14627

- (1) 16131.5 pyranometer
- (2) mounting plate for pyranometer\*
- (3) fixation for mounting on traverse system 14627\*
- (4) TORX M4 x 16 TX20 DIN 7985 TX A2
- (5) washer 4.3 DIN 125 A A2
- (6) washer 5.3 DIN 125 A A2
- (7) hexagon screw M8 x 16 DIN 933 A2
- (8) nut M5 DIN 934 A2
- (9) nut M8 DIN 985 A2
- (10) nut M4 DIN 985 A4
- (11) setscrew M4 DIN 985 A4

\* Parts of the “Set for inclined mounting on traverse system 14627”

#### 4.4 Electrical connection of active 16131.5 series: wiring diagram

The instrument must be powered by an external power supply, providing an operating voltage in the range from 8 to 30 VDC. This is the main power supply for the sensor, using the brown and white wires.

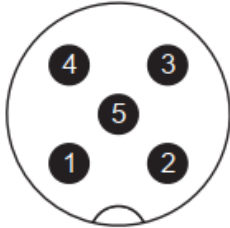

Figure 4.4.1: Connector layout of 16131.5, indicating PIN numbers (viewed from cable side)

##### 4.4.1 Wiring diagram 00.16131.501030 - Modbus RTU

Table 4.4.1.1 Wiring diagram of 00.16131.501030

PIN	WIRE	00.16131.501030 Modbus over RS-485
1	Brown	VDC [+]
2	White	VDC [-] / heater [-]
3	Blue	RS-485 B / B' [+]
4	Black	RS-485 A / A' [-]
5	Grey	heater [+]
	Shield mesh	shield

Note 1: At the connector-end of the cable, the shield is connected to the connector housing.

Note 2: The heater is powered by applying a voltage to the grey wire, an operating voltage of 12 VDC is used.

Note 3: Do not put more than 30 Volt across these wires, this will damage the sensor.

##### 4.4.2 Wiring diagram 00.16131.501040 - Modbus RTU

Table 4.4.2.1 Wiring diagram of 00.16131.501040

PIN	WIRE	00.16131.501040 Modbus over TTL	00.16131.501040 4 to 20 mA output
1	Brown		VDC [+]
2	White		not connected
3	Blue	On request	4 to 20 mA output
4	Black		not connected
5	Grey		not connected
	Shield mesh		shield

Note 1: At the connector-end of the cable, the shield is connected to the connector housing.

## 4.5 Electrical connection of passive 16131.5: wiring diagram

16131.5 is a passive sensor that does not need any power. Cables generally act as a source of distortion, by picking up capacitive noise. We recommend keeping the distance between a datalogger or amplifier and the sensor as short as possible. For cable extension, see the appendix on this subject.

**Table 4.5.1** Wiring diagram of 00.16131.501000

PIN	WIRE	00.16131.501000 Analogue millivolt output
1	Brown	heater
4	Black	heater
3	Blue	not connected
2	White	signal [+]
5	Grey	signal [-]
	Shield mesh	shield

Note 1: The heater is a resistive heater element

Note 2: At the connector-end of the cable, the shield is connected to the connector chassis and thereby to the sensor housing

## 4.6 Grounding and use of the shield

Grounding and shield use are the responsibility of the user. The cable shield (called shield in the wiring diagram) is connected to the aluminum instrument body via the connector. In most situations, the instrument will be screwed on a mounting platform that is locally grounded. In these cases, the shield at the cable end should not be connected at all. When a ground connection is not obtained through the instrument body, for instance in laboratory experiments, the shield should be connected to the local ground at the cable end. This is typically the ground or low voltage of the power supply or the common of the network. In exceptional cases, for instance when both the instrument and a datalogger are connected to a small size mast, the local ground at the mounting platform is the same as the network ground. In such cases ground connection may be made both to the instrument body and to the shield at the cable end.

## 4.7 Using heater of 00.16131.501030 and 00.16131.0501000

00.16131.501030 and 00.16131.501000 have an on-board heater. Heating the sensor contributes to the dependability and accuracy of the measurement, helping to prevent dew and frost deposition. The heater is typically switched on at night-time only. During the daytime it is recommended to switch off the heater. Note that using the heater without any additional ventilation may cause zero offsets.

External ventilation can be used to reduce or eliminate the effect of heating. Note that when the heater is not used, it has no impact on the instrument specifications.

The integrated heater is a resistive element with a constant resistance. This means that the generated heating power increases with the applied voltage. When the heater resistance  $R$ , and voltage  $V$ , are known, the generated heater power  $P$ , is given by:

$$P = V^2 / R$$

A heating power of approximately 1.5 W is typically sufficient. With a heater resistance of 95  $\Omega$ , as specified in the specifications table, 12 VDC is required to generate this power.

## 4.8 Using 00.16131.501040's analogue 4 to 20 mA output

16131.5 gives users the option to use 4 to 20 mA output instead of its digital output. When using 4 to 20 mA output, please read this chapter first.

Using the 4 to 20 mA output provided by 00.16131.501040 is easy. The instrument can be connected directly to commonly used data-logging systems.

The irradiance,  $E$ , in  $W/m^2$  is calculated by the formula:

$$E = 1600 \cdot (I - 4 \times 10^{-3}A) / (16 \times 10^{-3}A)$$

I: Current output in A  
E: Solar irradiance in  $W/m^2$

By convention 0  $W/m^2$  irradiance corresponds with  $4 \times 10^{-3}$  A transmitter output current  $I$ . The transmitted range, which is the irradiance at output current of  $20 \times 10^{-3}$  A, and is typically 1600  $W/m^2$ .

**It is important to realize that the signal wires not only act to transmit the signal but also act as power supply for the 4-20 mA current loop circuit!**

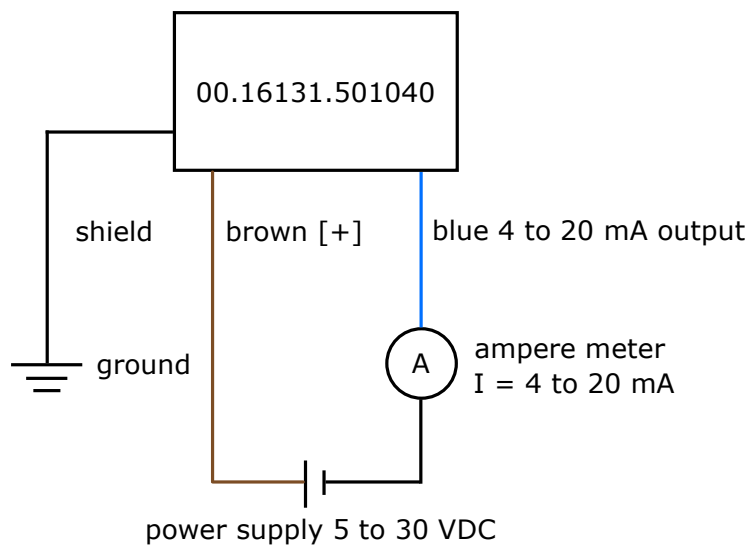

**Figure 4.8.1** Electrical diagram of the connection of 00.16131.501040 to a typical ampere meter or datalogger with capability to measure current signals.

Usually a  $100 \Omega$  shunt resistor ( $R$ ) is used to convert the current to a voltage (this will then be in the 0.4 – to 2 VDC range). This resistor must be put in series with the blue wire of the sensor.

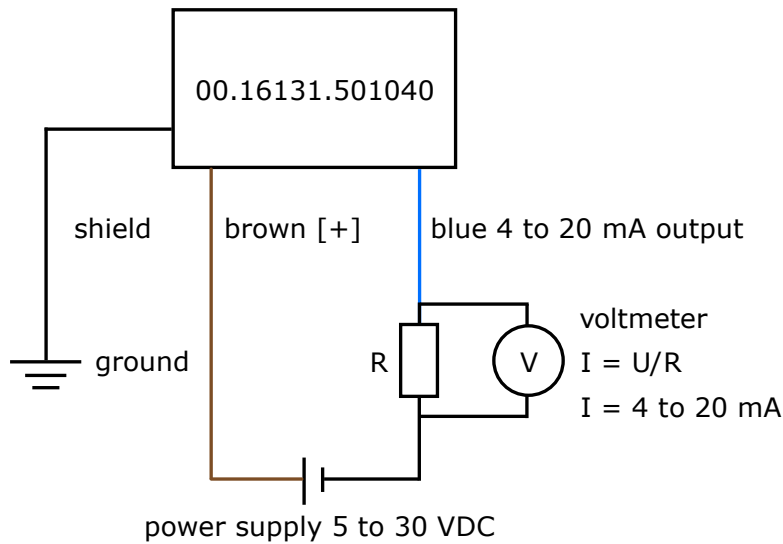

**Figure 4.8.2** Electrical diagram of the connection of 00.16131.501040 to a typical voltmeter or data-logger with the capability to measure voltage signals.

#### 4.9 Data acquisition requirements for using 00.16131.501000's millivolt output

The selection and programming of data loggers is the responsibility of the user. The LAMBRECHT meteo data logger Ser[LOG] Plus is ideally suited for solar irradiance measurement using a pyranometer with millivolt output.

00.16131.501000 can usually be treated in the same way as other thermopile pyranometers.

**Table 4.9.1** Requirements for data acquisition and amplification equipment for 00.16131.501000 in the standard configuration

Capability to measure small voltage signals	preferably: $5 \times 10^{-6} \text{ V}$ uncertainty minimum requirement: $20 \times 10^{-6} \text{ V}$ uncertainty (valid for the entire expected temperature range of the acquisition / amplification equipment)
Capability for the data logger or the software	to store data, and to perform division by the sensitivity to calculate the solar irradiance. $E = U/S$
Data acquisition input resistance	$> 1 \times 10^6 \Omega$
Open circuit detection (WARNING)	open-circuit detection should not be used, unless this is done separately from the normal measurement by more than 5 times the sensor response time and with a small current only. Thermopile sensors are sensitive to the current that is used during open circuit detection. The current will generate heat, which is measured and will appear as an offset.

## 4.10 Connecting to an RS-485 network

16131.5 is designed for a two-wire (half-duplex) RS-485 network. In such a network, 16131.5 acts as a slave, receiving data requests from the master. An example of the connection to an RS-485 two-wire network is shown in the figure below. 16131.5 is powered from 5 to 30 VDC. The power supply is not shown in the figure. The VDC [-] power supply ground must be connected to the common line of the network. [Modbus over serial line specification and implementation guide V1.02 (www.modbus.org).]

After the last nodes in the network, on both sides, line termination resistors (LT) are required to eliminate reflections in the network. According to the RS-485 standard, these LT have a typical value of 120 to 150  $\Omega$ . Never place more than two LT on the network and never place the LT on a derivation cable. To minimize noise on the network when no transmission is occurring, a pull up and pull down resistor are required. Typical values for both resistors are in the range from 650 to 850  $\Omega$ .

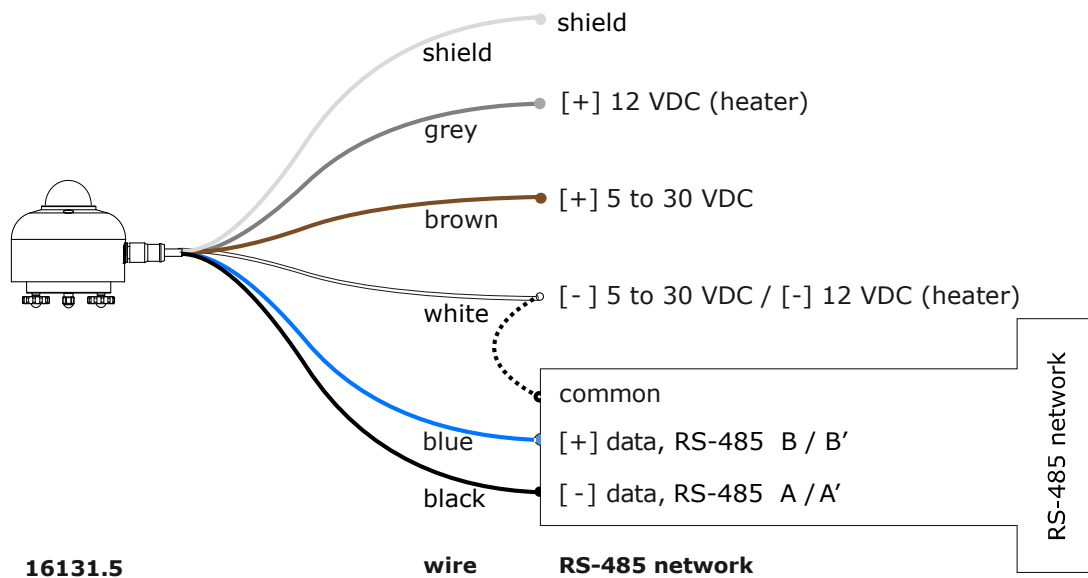

**Figure 4.10.1** Connecting 16131.5 to a typical RS-485 network

## 5 Communication with 16131.5

### 5.1 Modbus-protocol

The LAMBRECHT meteo Modbus sensors and the met[LOG] follow the specification of the Modbus organization: "MODBUS APPLICATION PROTOCOL SPECIFICATION V1.1b3" (see [www.modbus.org](http://www.modbus.org)).

### 5.2 Data encoding

MODBUS uses the "big-endian" format for addresses and data. This means that if a value is transmitted with a number format that is larger than a single byte, the "most significant byte" is sent first. For values that go beyond one register (e.g. 32 bit) this is not clearly specified for the Modbus. In these cases (32 bit or 64 bit) the LAMBRECHT Modbus sensors follow the big-endian number format.

#### Example Big-Endian:

Register size value

16 - Bits 0x1234 is transmitted in the order: 0x12 0x34.

#### Example big-endian (32bit or 64bit):

Register size value

32 - Bits 0x12345678 is transmitted in the order: 0x12 0x34 0x56 0x78.

### 5.3 Device-address

The addresses 1...247 are permitted for Modbus.

*Warning: Using the same Modbus address for more than one device will lead to irregular behavior of the entire network.*

### 5.4 Standard configuration - default

Baud rate: 19200 Baud

Address: Each sensor type (or family) has its own default address.

**Table 5.4.1** Default addresses of the LAMBRECHT sensors

Address	Sensor
1	Wind speed
2	Wind direction
3	Precipitation rain[e]
4	THP
5	EOLOS IND
6	com[b]
7	PREOS
8	ARCO
9	u[sonic]
10	Pyranometer 2nd Class
11	Secondary standard Pyranometer, First Class Pyranometer
12	PT100 to Modbus converter (temperature)

Byte frame according to MODBUS standard for RTU mode:

8E1 (1 start bit, 8 data bits, 1 parity bit (even parity), 1 stop bit)

## 5.5 Modbus command set

The Lambrecht Modbus sensors support the following commands:

- Read Input Register" command: 0x04 (Read measured data)
- Write Multiple Register" command: 0x10 (Write sensor data)

## 5.6 Measured value and parameter register

The LAMBRECHT meteo Modbus provides in the register range 30001 to the measured values. The registers Addresses 30001 to 35000 apply to all LAMBRECHT meteo Modbus sensors, but are only available or valid if the respective sensor supports the corresponding values (e.g. a pure wind sensor does not provide any air humidity).

**Table 5.6.1** Measured values provided by 16131.5

Register address	Parameter name	Unit	Factor	Description	Data type
31401	Global radiation instantaneous values	W/m <sup>2</sup>	10	1 decimal	INT
31402	Global radiation - average value since last retrieval	W/m <sup>2</sup>	10	1 decimal	INT
31403	Global radiation - maximum value since last retrieval	W/m <sup>2</sup>	10	1 decimal	INT
31404	Global radiation - minimum value since last retrieval	W/m <sup>2</sup>	10	1 decimal	INT
31501	Global radiation instantaneous values (High-WORD) (temperature compensated)	W/m <sup>2</sup>	100	2 decimal The register 31501 + 31502 should be read in one sequence. (function code 0x04)	LONG
31502	Global radiation instantaneous values (Low-WORD) (temperature compensated)				

Register 31501 + 31502, Global radiation instantaneous values (Irradiance), provides the solar radiation output in 0.01 W/m<sup>2</sup>. The value given must be divided by 100 to get the value in W/m<sup>2</sup>. MSW and LSW should be read together in one request.

**Note:** The values from the registers with the maximum values (31403) and minimum values (31404) are automatically reset as soon as the register (31402) with the mean values has been read out.

The Lambrecht sensors give 0xD8F1=-9999(16bit) or 0xFF676981=-9999999 (32bit) as error code or invalid value.

**Note:** Individual readout of related registers (e.g. 31501 and 31502) is not permitted.

## 5.7 Additional value registers (Service)

**Table 5.7.1**

Register address	Parameter name	Unit	Factor	Description	Data type
6	Sensor body temperature	°C	100	2 decimal	INT

Register 6, *Instrument body temperature*, provides the temperature of the instrument body in 0.01 °C. The data must be divided by 100 to achieve the value in °C.

## 5.8 Sensor parameters / configuration-parameters

**Table 5.8.1** Configuration registers

Register address	Parameter name	Unit	Divisor	Description	Data type
40001	Modbus device address		1	The addresses 1...247 are allowed.	INT
40200	Baud rate		0,01	96=9600 192=19200 384=38400	INT
46000	Number of mapping-registers*		1	Contains the number of occupied mapping registers for the auto-configuration 16131.5 = 6	INT

\* For more information about the registers for auto-configuration see Appendix.

Register 40001, Modbus device address, contains the Modbus address of the sensor. This allows the Modbus master to detect the slave, 16131.5, in its network. The address can be changed; the value of the address must be between 1 and 247. The default Modbus address is 11.

**Note:** The sensor needs to be restarted before changes become effective.

Register 40200, Baud rate, is used to enter the settings for the baud rate. The framing of the serial data transfer is 8 data bits, even parity and 1 stop bit. Default setting is 19200 baud.

**Note:** The sensor needs to be restarted before changes become effective.

**Table 5.8.2** Format of data

DATA TYPE	DESCRIPTION
uINT	Unsigned 16 bit integer
INT	Signed 16 bit integer
uLONG	Unsigned 32 bit integer
LONG	Signed 32 bit integer

The data format includes *signed* and *unsigned* integers. The difference between these types is that a *signed* integer passes on negative values, which reduces the range of the integer by half. Up to five 16 bit registers can be requested in one request; if requesting six or more registers, multiple requests should be used.

If the format of data is a signed or an unsigned 32 bit integer, the first register received is the most significant word (MSW) and the second register is the least significant word (LSW). This way two 16 bit registers are reserved for a 32 bit integer. MSW and LSW must be read together in one request. This is necessary to make sure both registers contain the data of one internal measurement.

## 5.9 Network communication: getting started

Once it has the correct Modbus address and communication settings, 16131.5 can be connected directly to an RS-485 network and a power supply.

Installing a 16131.5 in the network also requires configuring the communication for this new Modbus device. This usually consists of defining a request that can be broadcast by the master.

Typical operation requires the master to make a request of irradiance data in registers 31501 + 31502 every 1 second, and store the 60 second averages. The data format of register 31501 + 31502 is a signed 32 bit integer.

**Note:** Up to five 16 bit registers can be requested in one request. In case six or more registers are requested in just one request, 16131.5 will not respond. If requesting six or more registers, multiple requests should be used: 16131.5 will respond as expected.

## 5.10 Adapting the Modbus address and communication settings

Setting the instrument address and baud rate can be done in different ways:

- by connecting the sensor to the PC and using a Modbus testing tool. There are links to different solutions available at [www.modbus.org](http://www.modbus.org);
- by using the available network user interface software.

The Modbus address is stored in register 40001 and has a default value of 11. A user may change the address to a value in the range of 1 to 247. The address value must be unique in the network. The baud rate is stored in register 40200.

The default communication frame is 19200 baud, with even parity bit, 8 data bits and 1 stop bit. After a new address or communication setting is written the sensor must be restarted.

## 6 Maintenance and trouble shooting

### 6.1 Recommended maintenance and quality assurance

16131.5 can measure reliably at a low level of maintenance in most locations. Usually, unreliable measurements will be detected as unreasonably large or small measured values. Generally this means that regular visual inspection combined with a critical review of the measured data, preferably checking against other measurements, is the preferred way to obtain a reliable measurement.

**Table 6.1.1** Recommended maintenance of 16131.5.

*If possible, the data analysis and cleaning (1 and 2) should be done on a daily basis.*

<b>MINIMUM RECOMMENDED PYRANOMETER MAINTENANCE</b>			
	INTERVAL	SUBJECT	ACTION
1	1 week	data analysis	compare measured data to maximum possible / maximum expected irradiance and to other measurements nearby (redundant instruments). Also, historical seasonal records can be used as a source for expected values. Analyze night time signals. These signals may be negative (down to - 5 W/m <sup>2</sup> on clear windless nights), due to zero offset a. In case of use with PV systems, compare daytime measurements to PV system output. Look for any patterns and events that deviate from what is normal or expected.
2	2 weeks	cleaning	use a soft cloth to clean the dome of the instrument, persistent stains can be treated with soapy water or alcohol
3	6 months	inspection	inspect cable quality, inspect connectors, inspect mounting position, inspect cable, clean instrument, clean cable, inspect levelling, change instrument tilt angle in case this is out of specification, inspect mounting connection, inspect interior of dome for condensation
4	2 years	recalibration	recalibration by side-by-side comparison to a higher standard instrument in the field according to ISO 9847
5		lifetime assessment	judge if the instrument should be reliable for another 2 years, or if it should be replaced
6	> 5 years	desiccant replacement	desiccant replacement by manufacturer.
7		parts replacement	if applicable / necessary, replace the parts that are most exposed to ageing and weathering; cable, connector, sun screen, ventilator. NOTE: use manufacturer approved parts only. ventilator replacement by manufacturer.

## 6.2 Trouble shooting

**Table 6.2.1** *Trouble shooting for 00.16131.501030 and 00.16131.501040*

General	<p>Inspect the instrument for any damage.</p> <p>Inspect if the connector is properly attached.</p> <p>Check the condition of the connectors (on chassis as well as the cable).</p> <p>Inspect if the sensor receives DC voltage power in the range of 5 to 30 VDC.</p> <p>Inspect the connection of the shield (typically not connected at the network side).</p> <p>Inspect the connection of the sensor power supply, typically the negative is connected to the network <i>common</i>.</p>
Prepare for indoor testing	<p>Install a Modbus tool on a PC. Equip the PC with RS-485 communication. Put DC voltage power to the sensor and establish communication with the sensor. At power-up the signal may have a temporary output level different from zero; an offset. Let this offset settle down.</p>
The sensor does not give any signal	<p>Check if the sensor reacts to light: expose the sensor to a strong light source, for instance a 100 W light bulb at 0.1 m distance. The signal should read <math>&gt; 100 \text{ W/m}^2</math> now. Darken the sensor either by putting something over it or switching off the light. The instrument voltage output should go down and within one minute approach <math>0 \text{ W/m}^2</math>. Check the data acquisition by replacing the sensor with a spare sensor with the same address.</p>
Not able to communicate with the sensor	<p>Check all physical connections to the sensor and try connecting to the sensor again. If communicating is not possible, try to figure out if the address and communication settings are correct. Analyze the cable performance by measuring resistance from pins to cable ends. The electrical resistance should be <math>&lt; 10 \Omega</math>. In case of doubt, try a new cable.</p> <p>If all physical connections are correct, and the sensor still cannot be found, please contact the factory to send the sensor to the manufacturer for diagnosis and service.</p>
16131.5 does not respond to a request for 6 or more registers	<p>It is not possible to request more than five 16 bit registers in one request. In case of requesting six or more registers in just one request, the sensor will not respond. If requesting six or more registers, use multiple requests: the sensor will respond as expected.</p>
The sensor signal is unrealistically high or low	<p>Note that night-time signals may be negative (down to <math>-5 \text{ W/m}^2</math> on clear windless nights in standard operating mode), due to zero offset a.</p> <p>Check if the pyranometer has clean domes.</p> <p>Check the location of the pyranometer; are there any obstructions that could explain the measurement result.</p> <p>Check the orientation / levelling of the pyranometer.</p> <p>Check the cable condition looking for cable breaks. Check the condition of the connectors (on chassis as well as the cable).</p>
The sensor signal shows unexpected variations	<p>Check the presence of strong sources of electromagnetic radiation (radar, radio).</p> <p>Check the condition and connection of the shield.</p> <p>Check the condition of the sensor cable.</p> <p>Check if the cable is not moving during the measurement.</p> <p>Check the condition of the connectors (on chassis as well as the cable)</p>
The outer dome shows internal condensation	<p>In case there is a minor layer of moisture that is hardly visible: Arrange to send the sensor to the manufacturer for diagnosis and service.</p>
The inner dome shows internal condensation	<p>Arrange to send the sensor to the manufacturer for diagnosis and service.</p>

**Table 6.2.2** *Trouble shooting for 00.16131.501000*

The sensor does not give any signal	<p>Check the electrical resistance of the sensor between the grey (-) and white (+) wire. Use a multimeter at the 1000 <math>\Omega</math> range. Measure the sensor resistance first with one polarity, then reverse the polarity. Take the average value. The typical resistance of the wiring is 0.1 <math>\Omega</math>/m. Typical resistance should be the typical sensor resistance of 50 to 150 <math>\Omega</math> plus 1.5 <math>\Omega</math> for the total resistance of two wires (back and forth) length of the used cable. Infinite resistance indicates a broken circuit; zero or a low resistance indicates a short circuit. Check if the sensor reacts to light: put the multimeter at its most sensitive range of DC voltage measurement, typically the <math>100 \times 10^{-3}</math> VDC range or lower. Expose the sensor to strong light source, for instance a 100 W light bulb at <math>1 \times 10^{-1}</math> m distance. The signal should read <math>&gt; 2 \times 10^{-3}</math> V now. Darken the sensor either by putting something over it or switching off the light. The instrument voltage output should go down and within one minute approach 0 V. Check the data acquisition by applying a <math>1 \times 10^{-6}</math> V source to it in the <math>1 \times 10^{-6}</math> V range. Check the condition of the connectors (on chassis as well as the cable).</p>
The sensor signal is unrealistically high or low.	<p>Note that night-time signals may be negative due to zero offset and heating offsets when the heater is used. The contribution from zero offset can be down to -5 W/m<sup>2</sup>, offset due to heating can be -8 W/m<sup>2</sup>.</p> <p>Check if the pyranometer has clean domes.</p> <p>Check the location of the pyranometer; are there any obstructions that could explain the measurement result.</p> <p>Check the orientation / levelling of the pyranometer.</p> <p>Check if the right calibration factor is entered into the algorithm. Please note that each sensor has its own individual calibration factor, as documented in its calibration certificate.</p> <p>Check if the voltage reading is divided by the calibration factor in review of the algorithm.</p> <p>Check the condition of the wiring at the logger.</p> <p>Check the cable condition looking for cable breaks. Check the condition of the connectors (on chassis as well as the cable). Check the range of the data logger; signal can be negative (this could be out of range) or the amplitude could be out of range. Check the data acquisition by applying a <math>1 \times 10^{-6}</math> V source to it in the <math>1 \times 10^{-6}</math> V range. Look at the output. Check if the output is as expected.</p> <p>Check the data acquisition by short circuiting the data acquisition input with a 100 <math>\Omega</math> resistor. Look at the output. Check if the output is close to 0 W/m<sup>2</sup>.</p>
The sensor signal shows unexpected variations	<p>Check the presence of strong sources of electromagnetic radiation (radar, radio)</p> <p>Check the condition of the shielding.</p> <p>Check the condition of the sensor cable.</p> <p>Check if the cable is not moving during the measurement</p> <p>Check the condition of the connectors (on chassis as well as the cable)</p>
The outer dome shows internal condensation.	<p>In case there is a minor layer of moisture that is hardly visible: Arrange to send the sensor back to LAMBRECHT for diagnosis.</p>
The inner dome shows internal condensation	<p>Arrange to send the sensor back to LAMBRECHT for diagnosis.</p>

## 7 Appendices

### 7.1 LAMBRECHT meteo – Auto-configuration

The Modbus sensors from LAMBRECHT meteo offer the possibility of auto-configuration. This is supported e.g. by the LAMBRECHT meteo data logger met[LOG]. For the auto-configuration, the register addresses of the measured values and sensor data available in the register range 30001 to 35000 are listed as successive values in the Lambrecht sensors in register range 46001 to 49000. Registers 46001 to 49000 can only be read out as a block! The length of the block or the number of available mapping registers is in holding register 46000.

**Table 7.1.1** *Number of mapping-registers*

Register address	Parameter name	Unit	Divisor	Description	Data type
46000	Number of mapping-registers		1	Contains the number of occupied mapping registers for the auto-configuration 16131.5 = 6	INT

Since the addresses from the range 30001 to 35000 apply to all Lambrecht sensors, an address from this range is also representative of a measured value type.

For example, register 30401 always contains the current value of the air temperature. If this register address is not included in the list in register range 46001 to 49000, the connected Modbus sensor does not supply an air temperature.

If the auto-configuration is started with the data logger met[LOG], it queries the available mapping registers on each COM interface in the device address range 1...25. For this purpose, the number of mapping registers is read from register 46000 and the register range starting at 46001 is read out as a block.

The following table contains the assignment of the configuration to the individual (possible) instantaneous value registers of the sensors. Some sensors deliver registers with mean (average), minimum and maximum values or additional values beyond this specification. Unknown register addresses (or registers that are not required) must therefore be ignored during auto-configuration.

Register address	Parameter name	Unit	Factor	Description	Data type	Function-code	Storage-type >16 bit
30001	Wind speed instantaneous value	m/s	10	1 decimal place	INT	0x04	Big-Endian WORD
30201	Wind direction instantaneous value	°	10	1 decimal place	INT	0x04	Big-Endian WORD
30401	Air temperature instantaneous value	°C	10	1 decimal place	INT	0x04	Big-Endian WORD
30601	Humidity instantaneous value	% r.h.	10	1 decimal place	INT	0x04	Big-Endian WORD
30701	Dew point instantaneous value	°C	10	1 decimal place	INT	0x04	Big-Endian WORD
30801	Air pressure instantaneous value	hPa	10	1 decimal place	INT	0x04	Big-Endian WORD
31001	Precipitation amount total	mm	10	1 decimal place	INT	0x04	Big-Endian WORD
31101	Precipitation amount total (High-WORD)	mm	1000	3 decimal places Registers 31101 + 31102 can only be read out together. (function code 0x04)	LONG	0x04	Big-Endian LONG
31102	Precipitation amount total (Low-WORD)					0x04	
31201	Precipitation intensity 1-minute sliding	mm/min	1000	= average (1-min.) 3 decimal places Time base = 1 min. Meas. rate =6x per min.	INT	0x04	Big-Endian WORD
31401	Global radiation instantaneous value	W/m <sup>2</sup>	10	1 decimal place	INT	0x04	Big-Endian WORD
31501	Global radiation instantaneous values (High-WORD) (temperature compensated)	W/m <sup>2</sup>	100	2 decimal places Registers 31501 + 31502 can only be read out together. (function code 0x04)	LONG	0x04	Big-Endian WORD
31502	Global radiation instantaneous values (Low-WORD) (temperature compensated)					0x04	
31591	Global radiation instantaneous values (High-WORD) (uncompensated)	W/m <sup>2</sup>	100	2 decimal places Registers 31591 + 31592 can only be read out together. (function code 0x04)	LONG	0x04	Big-Endian WORD
31592	Global radiation instantaneous values (Low-WORD) (uncompensated)					0x04	

Registers Address 46001-49000 containing for each sensor the available registers with measured values and sensor data from the range 30001-35000.

**The registers can only be read out as a block! The length of the block or the number of available mapping registers is in holding register 46000**

For example, in the 16131.5, registers 46001 to 46008 contain valid addresses. The holding register 46000 contains the number of registers “6”, all 6 registers must be read out in the block with the function code 0x04. Too many registers or too few lead to an error message.

**Table 7.1.3 Mapping-Register for auto-configuration**

Register address	Register value	Unit	Factor	Description	Data type
46001	31401	Register address	1	Global radiation instantaneous values	INT
46002	31402	Register address	1	Global radiation - average value since last retrieval	INT
46003	31403	Register address	1	Global radiation - maximum value since last retrieval	INT
46004	31404	Register address	1	Global radiation - minimum value since last retrieval	INT
46005	31501	Register address	1	Global radiation instantaneous values (High-WORD) (temperature compensated)	INT
46006	31502	Register address	1	Global radiation instantaneous values (Low-WORD) (temperature compensated)	INT

Note 1: Usually, maximal up to five 16 bit registers can be requested from 16131.5 in one request. Just the 6 mapping registers for the auto-configuration can be requested in one request. For all other registers applies “if requesting six or more registers, use multiple requests”.

## 7.2 EU declaration of conformity



We, LAMBRECHT meteo GmbH.  
Friedlaender Weg 65  
37085 Goettingen  
Germany

in accordance with the requirements of the following directive:

2014/30/EU The Electromagnetic Compatibility Directive

hereby declare under our sole responsibility that:

Product model: 00.16131.501000, 00.16131.501030, 00.16131.501040  
Product type: Pyranometer

has been designed to comply and is in conformity with the relevant sections and applicable requirements of the following standards:

Emission: IEC/EN 61000-6-1, Class B, RF emission requirements, IEC CISPR11  
and EN 55011 Class B requirements  
Immunity: IEC/EN 61000-6-2 and IEC 61326 requirements

Copyright © 2025 LAMBRECHT meteo GmbH. All rights reserved.

Information in this document subject to change without notice.

Photo copyright: © gopixa- Adobe stock

16131\_5\_Manual 06.25

---

LAMBRECHT meteo GmbH  
Friedlaender Weg 65  
37085 Goettingen  
Germany

Tel +49-(0)551-4958-0  
E-Mail info-lambrecht@aem.eco  
Internet www.lambrecht.net