



USER MANUAL

rain[e]

Precipitation Sensors



Content

1	Scope of delivery	4
2	Order codes	5
3	Safety instructions and warranty	5
4	Dimensional and product drawings	6
5	Introduction	7
5.1	Heating	8
6	Installation	9
6.1	Selection of the installation site	9
6.2	Mounting	9
6.3	Integrated collecting system	10
6.4	Power and signal connection	13
6.5	System start	13
6.6	Available interfaces	14
6.7	Factory settings (heated / unheated)	14
6.7.1	Factory settings rain[e], rain[e]314, rain[e]400	14
6.7.2	Factory settings rain[e]LP	15
6.7.3	Factory settings Modbus versions	15
6.8	Terminal assignment	15
7	Configuration software rain[e] Commander	24
8	Input and Output	30
8.1	SDI-12 Interface	30
8.2	RS485 Interface	38
8.2.1	SDI-12 Protocol	38
8.2.2	WLASCII Protocol	38
8.2.3	Talker protocol	40



8.2.4	Modbus protocol	41
8.2.4.1	Data encoding	41
8.2.4.2	Device address	41
8.2.4.3	Standard configuration - Default	42
8.2.4.4	Modbus command set	42
8.2.4.5	Measured value and parameter register LAMBRECHT sensors	42
8.2.4.5.1	Special case precipitation quantity	43
8.2.4.5.2	Sensor status	43
8.2.4.6	Descriptive sensor parameter registers (Holding register)	44
8.2.4.7	Sensor parameters / Configuration parameters	44
8.2.4.8	Autoconfiguration	45
8.3	Total precipitation	45
8.4	Pulse output	45
8.5	Analog output	46
9	Inspection and troubleshooting	46
10	Maintenance and repair	47
11	Equipment and spare parts	48
12	Download of updates	49
13	Technical data I	50
14	Technical data II	51
15	Technical data III	52
16	Technical data IV	53

The rain[e] series

rain[e] is a new type of precipitation sensor that combines highest resolution with a very compact design. The unique, continuously self-emptying collection system enables the measurement of each single drop. The rain[e] series is compatible with a wide range of data loggers and ideal for setting up measurement networks.

FEATURES

- Latest weighing technology, compact design
- Fully automatic continuous emptying prevents overflow and incorrect measurements
- DAkkS proof of non-impact of the measurement sensor by wind and solar radiation
- Wide range of signal outputs:
 - Two independently configurable pulse outputs
 - SDI-12
 - RS485 (SDI-12 protocol, ASCII protocol, TALKER protocol)
 - Analog output
 - Modbus
- Cold climate model with two electronically controlled heating circuits
- Environmentally friendly, as free of antifreeze agent
- Models with 200 cm², 314 cm², and 400 cm² collecting area
- WMO compliant

1 Scope of delivery

- rain[e] precipitation sensor
- Collecting vessel
- USB cable for configuration; L = 1 m
- User manual
- Configuration software rain[e] Commander (country-specific as CD or download)

Check the delivery for transport damage and, if necessary, document this in detail for subsequent claims for damages against the supplier. Then contact the LAMBRECHT meteo service under **+49-(0)551-4958-0** or **info@lambrecht.net**

2 Order codes

Heated versions		Unheated versions	
rain[e] (heated)	00.15184.400000	rain[e] (unheated)	00.15184.000000
rain[e]one Modbus (heated)	00.15184.400101	rain[e]one Modbus (unheated)	00.15184.000101
rain[e] 314 (heated)	00.15184.403000	rain[e] 314 (unheated)	00.15184.003000
rain[e] 400 (heated)	00.15184.404000	rain[e] 400 (unheated)	00.15184.004000
The order codes for accessories and spare parts can be found in the chapter "Equipment and spare parts".		rain[e]LP (unheated)	00.15184.010000

3 Safety instructions and warranty

This system is designed according to the state-of-the-art accepted safety regulations. However, please note the following rules:

1. Before putting into operation please read all respective manuals!
2. Please observe all internal and state-specific guidelines and/or rules for the prevention of accidents. If necessary ask your responsible safety representative.
3. Use the system only as described in the manual.
4. Always have the manual at hand at the installation site.
5. Use the system within the specified operating condition. Eliminate influences, which might impair the safety.
6. Prevent the ingress of unwanted liquids into the devices.
7. Funnel heating and drain heating can be very hot if the heating is operated with the housing open. There is a risk of being burnt! It is therefore recommended that the connector of the heating supply is disconnected during cleaning and maintenance work.
8. The measuring edge of the upper part of the housing is quite sharp. There is a risk of cutting injuries. It is therefore recommended not to press on the measuring edge and/or to wear gloves!

Please note the loss that unauthorized manipulation of the system shall result in the loss of warranty and non-liability. Changes to system components require express written permission from LAMBRECHT meteo GmbH. These activities must be performed by a qualified technician.

The warranty does not cover:

1. Mechanical damage caused by external impacts (e.g. icefall, rockfall, vandalism).
2. Impacts or damage caused by over-voltage or electromagnetic fields which are beyond the standards and specifications of the device.
3. Damage caused by improper handling, e.g. by using the wrong tools, incorrect installation, incorrect electrical installation (e.g. incorrect polarity) etc.
4. Damage caused by using the device outside the specified operation conditions.

4 Dimensional and product drawings

rain[e]; rain[e]LP; rain[e]one Modbus

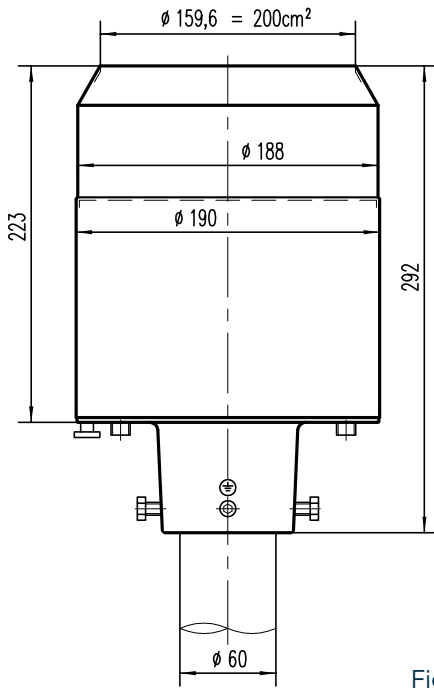

Fig. 1a

rain[e]400

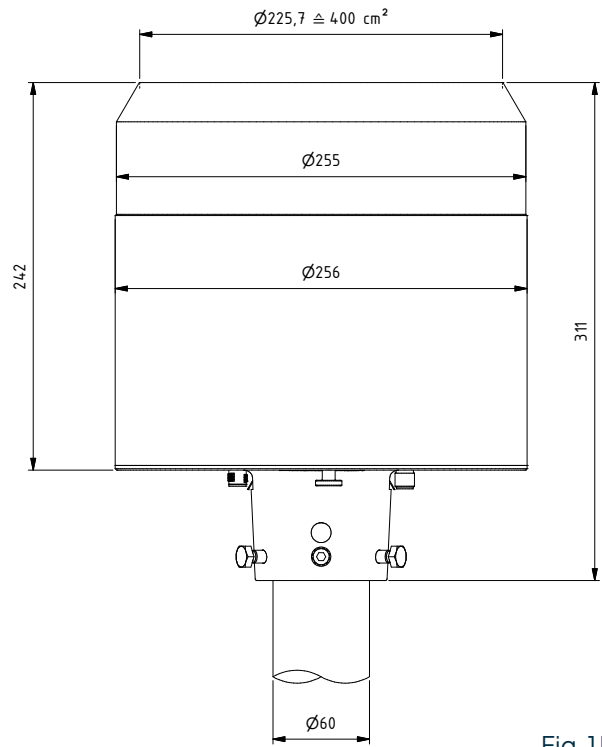

Fig. 1b

rain[e]314

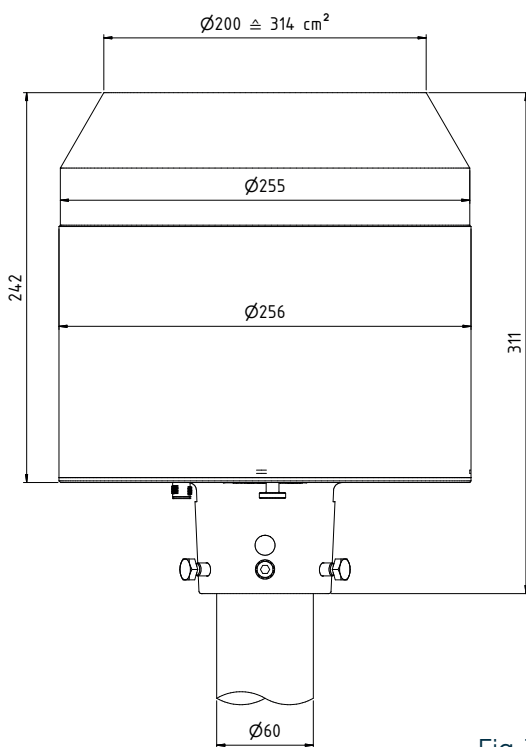

Fig. 1c

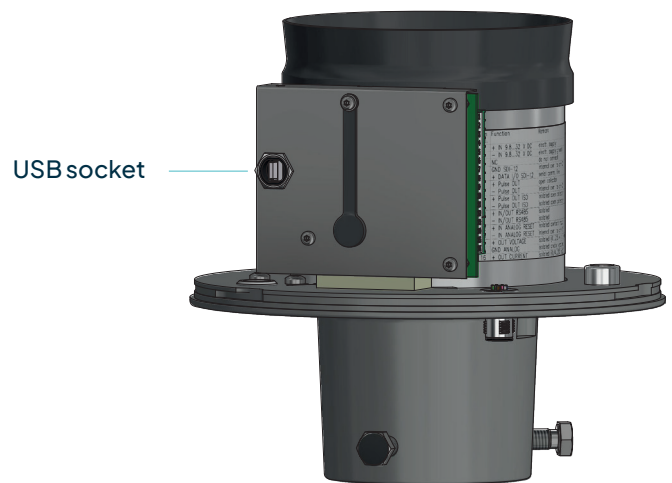

Fig. 1d

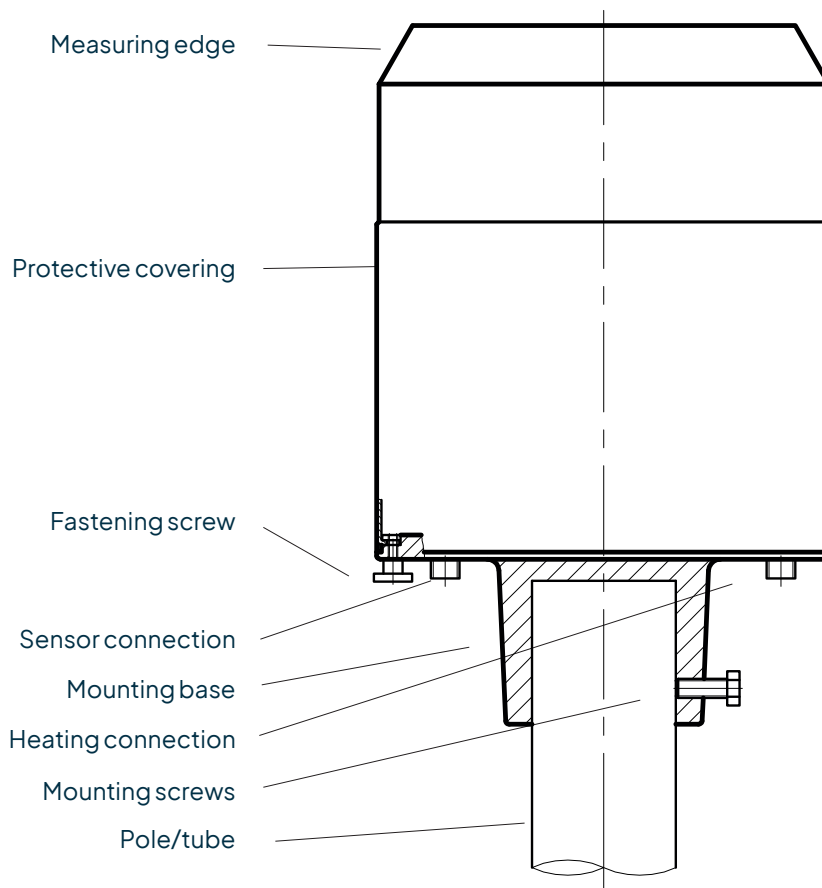

Fig. 2

5 Introduction

The precipitation sensor rain[e] measures precipitation amount and intensity. The rain[e] combines the advantages of the latest weighing technology and a self-emptying collecting vessel, allowing a high resolution and high precision at a very small total volume. Therefore the rain[e] has a higher resolution and precision than common tipping bucket sensors and at the same time is much smaller than common weighing sensors, since there is no need for a collecting container.

The main sensor is a highly precise load cell with overload protection. Its temperature coefficient can be determined using a temperature sensor in the interior space if necessary. The pulses from the reed contact generated by tipping the collecting vessel are used for error correction during periods of high intensity precipitation. Furthermore, the self-emptying system allows weighing without interruption.

The rain[e] calculates the following values:

- Amount of precipitation (pulse or analog output): The rain[e] outputs the amount of precipitation in real time via the pulse or analog output with a maximum resolution of 0.01 mm.
- Intensity within the last minute (SDI-12 or RS485 interface): The rain[e] measures 6 times per minute and sums these values up in a moving sum - that is, every time a new value is measured, it is summed to the previous 5 values and thus generates the new value for the intensity within the last minute.

- Intensity since last retrieval (SDI-12 or RS485 interface): The difference in the amount of precipitation since the last retrieval is divided by the time since the last retrieval. If the time is smaller than 30 s, the rain[e] will use the “intensity within the last minute” value.
- Amount since last retrieval (SDI-12 or RS485 interface): The difference in the amount of precipitation between the current and the last retrieval.
- Minimum intensity within the last x minutes (SDI-12 or RS485 interface): Every minute the value of the intensity within the last minute is compared to the current minimum value. If the new value is smaller, it replaces the former minimum value.
- Maximum intensity within the last x minutes (SDI-12 or RS485 interface): Every minute the value of the intensity within the last minute is compared to the current maximum value. If the new value is bigger, it replaces the former maximum value.
- Average intensity within the last x minutes (SDI-12 or RS485 interface): Counts the amount of precipitation in steps of 0.01 mm for x minutes and divides the result by x minutes.
- Variance (SDI-12 or RS485 interface): Variance of measured values over 4 s

The two pulse outputs can be configured to return the amount of precipitation with resolutions between 0.01 and 1 mm and closing times between 10 and 500 ms (see ch. 7 and ch. 8.3). Alternatively they can be configured to return the status Heating ON/OFF or Rain YES/NO. The analog output can be used in the two modes 0/4...20 mA or 0...2.5/5 V DC to return the amount of precipitation. For further details on the functioning of the analog output and the reset function see chapter 8.4 .

For further details on the way the values will be returned using SDI-12 protocol via SDI-12 or RS485 interface and the available commands see chapter 8.1 and 8.2.1. For further information regarding the configuration see chapter 7. In addition to SDI-12, the RS485 interface can be used in Talker or WL ASCII mode. For descriptions of these modes please see chapters 8.2.2 and 8.2.3.

5.1 Heating

For applications in regions with seasonal or permanent cold climate the rain[e] is available as a heated version. To melt solid precipitation in the funnel and prevent the outlets from complete icing the internal heating of the heated rain[e] is separated into two parts. An 80 W heating pad (resp. 150 W heating pad at rain[e]400) along the funnel surface and a 60 W heating plate below the protective wired grid and the collecting vessel. The targeted temperature of the inner funnel surface is 2 °C. The heated rain[e] is operational at -40...70 °C. The operational readiness is checked continuously and can be requested via SDI-12, RS485 or pulse output (see ch. 8.1 and 8.2 or ch. 7).

The heating can be switched off via the configuration software rain[e] Commander (see ch. 7). In the factory settings the heating is switched on. The heating uses a separate power cable.



Funnel heating and drain heating can be very hot if the heating is operated with the housing open. There is a risk of being burnt! It is therefore recommended that the connector of the heating supply is disconnected during cleaning and maintenance work.



6 Installation

6.1 Selection of the installation site

To minimise the entry of splash water it is recommended that sites with hard ground like concrete are avoided. Place the precipitation sensor on grass or other soft ground instead. In general the sensor should not be placed on slopes or roofs. We recommend installation of the precipitation sensor at a distance of at least 2 m from any obstacle or the obstacle height (above the gauge's orifice), as defined by the German Meteorological Service DWD or twice the obstacle height as defined by the WMO and preferably at a distance of four times the obstacle height. Vegetation around the site have to be clipped regularly to the height of the sensor to prevent them from disturbing the measurement and at the same time reduce wind influence.

6.2 Mounting

NECESSARY TOOLS

► **Wrench (13 mm); Allen key (6 mm); Slotted screwdriver (approx. 2.5 blade width)**

- Unpack the device.
- Take the box of the collecting vessel out of the funnel of the rain[e].
- Check the collecting vessel for transport damage and put it back into its box for later installation.
- Place the sensor on a tube or pole with an outer diameter of 60 mm. A metallic extension tube with a minimum length of 100 mm is recommended if a wooden pole is used. Use a wrench (13 mm) to tighten the screws in the mounting pedestal evenly.

! **Avoid damaging the upper measuring edge.**

- To improve operational safety in locations at risk of lightning strikes, we recommend grounding the sensor with the integrated grounding screw of the rain[e]. The illustration shows the steps of installation of an earthing connection with a cable clip and earthing screws onto the sensor. The other end of the cable should be connected to a ground nail.

! **The warranty for the device is excluded if damage occurs due to improper handling. This particularly includes the absence of proper grounding. Correct grounding according to DIN VDI/VDE 0100 is essential for the safety and functionality of the device. If you have any questions regarding installation, please contact us.**

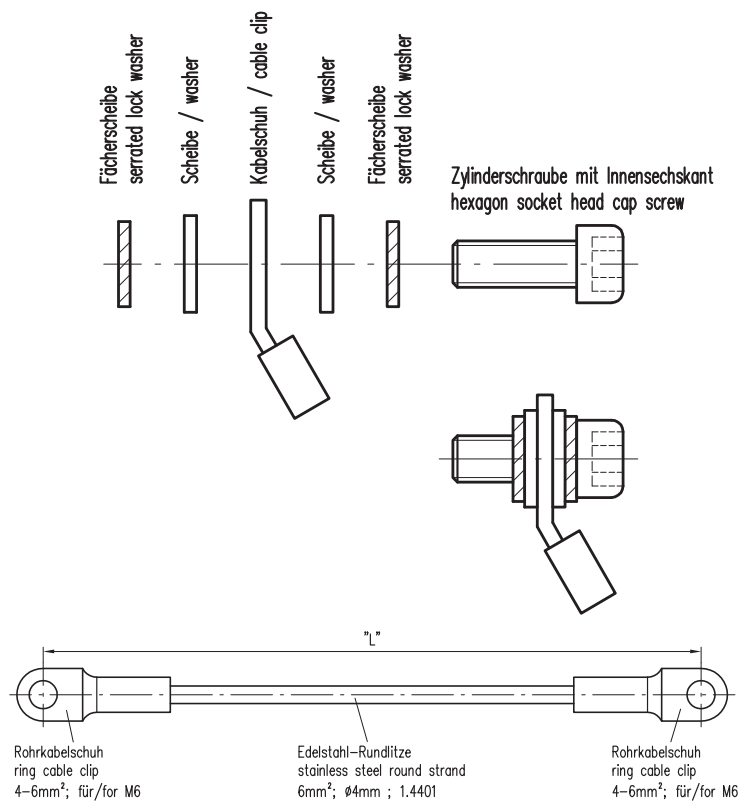

Fig. 3

6.3 Integrated collecting system

Illustrations using rain[e] as an example



Fig. 4

- Open the device.
 - Unscrew the knurled screw at the bottom.
 - Take hold of the casing and base and turn the casing in the “open” direction (anti-clockwise).
 - Lift the casing with caution. Mind the heater’s terminal plug.



The measuring edge of the upper part of the housing is quite sharp. There is a risk of cutting injuries. It is therefore recommended not to press on the measuring edge and/or to wear gloves!

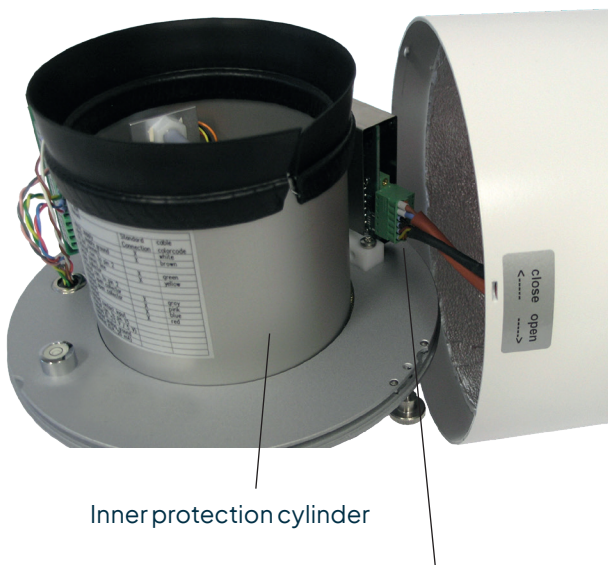
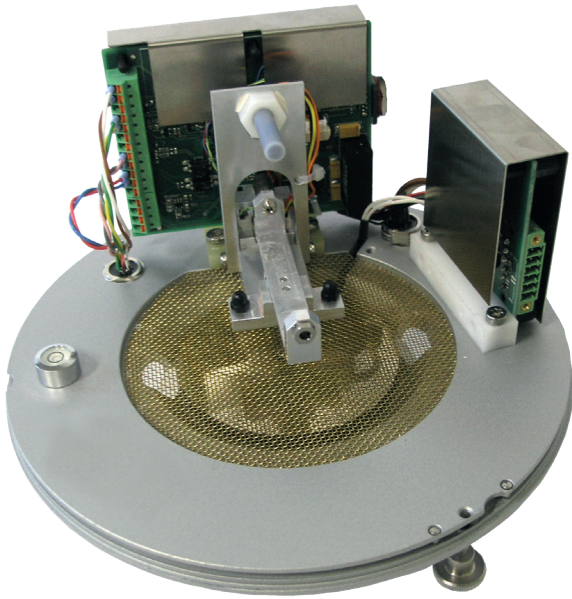

Fig. 5

Heating terminal plug

- Remove terminal plug.
- Place the housing aside.
- Lift inner protection cylinder.



rain[e] inner parts without collecting vessel

Fig. 6

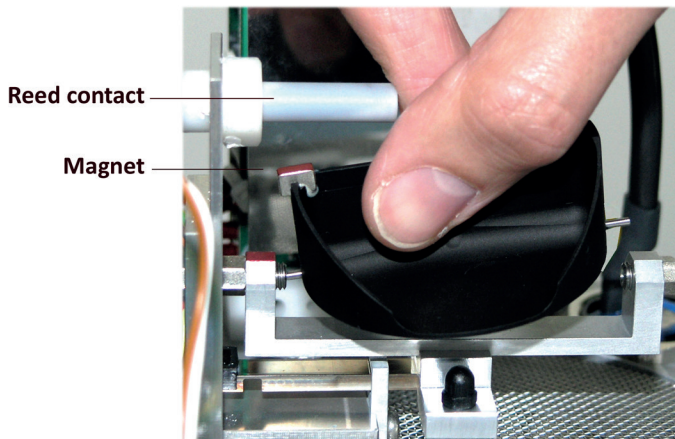

- Unpack the collecting vessel.
- Insert the collecting vessel.
 - Insert collecting vessel against the bearing spring with the site of the magnet facing towards the reed contact (Fig. 7)
 - Insert the other axis into the other bearing.
 - **Test for flawless tipping.**

Fig. 7

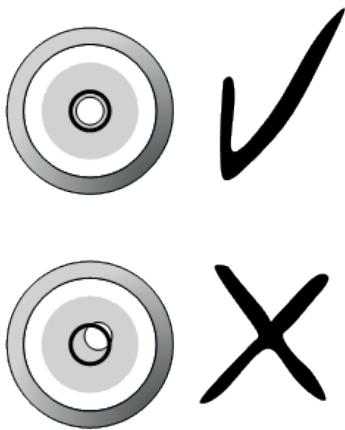

Fig. 8



Fig. 9

Level the device with the assistance of the spirit level (Fig. 8) by tightening the hexagon head screws in the base evenly.

- Reassembly
 - Cautiously put the inner protection cylinder back into place.
 - Plug in the terminal plug of the heating.
 - Put the casing onto the device; embossings into notches (Fig. 8).
 - Press down on the housing and turn it clockwise towards "close".
 - Fasten the knurled screw.
 - Insert the enclosed dirt trap spiral into the funnel (Fig. 10).



The measuring edge of the upper part of the housing is quite sharp. There is a risk of cutting injuries. It is therefore recommended not to press on the measuring edge and/or to wear gloves!



In order to protect the collecting vessel the dirt trap spiral must be inserted into the collecting funnel.

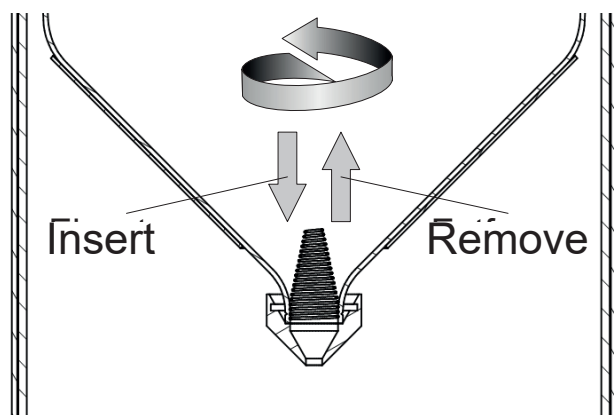

Fig. 10

- **Inserting of the dirt trap spiral**
Insert the enclosed dirt trap spiral in the funnel. The spiral should be held in such a way that a complete turn in the anti-clockwise direction is possible. Push the dirt trap spiral in circular motion from above into the funnel opening.
- **Removing the dirt trap spiral**
Grab the dirt trap spiral in such a way that a complete turn in the anti-clockwise direction is possible and pull it in a circular motion towards the funnel opening.

6.4 Power and signal connection

To connect the to a data acquisition system a M12 connecting cable (e.g. order code 32.15184.060000) is required. Connect the cable according to the “Wiring rain[e] without heating”. For the power supply of the heating, a power cable is required, which has to be connected to the power supply unit according to the “Wiring diagram rain[e] with heating”.

Connection cable for the sensor, 8-pole, 10 m	32.15184.060000
Connection cable for the Modbus sensor, 4-pole, 15 m	32.14567.060010
Power cable for the heating, 1 m	32.15184.061000



It is important to plug in the power plug of the heating first – before the terminal plug of the funnel heating and the sensor connector. Otherwise the automatic heating control will shut down the heating.

The maximum distance between the rain[e] and the data acquisition system depends on the interfaces being used. The values for SDI-12 and RS485 are obtained from the respective definitions of these standards.

- SDI-12 70 m, unshielded, low voltage cable
- RS485 1000 m
- Pulse output 1000 m

$$P_a = \frac{U_N^4}{P_N \left(\frac{U_N^2}{P_N} + 2\rho \frac{l}{A} \right)^2}$$

If a power cable longer than our recommended 1 m power supply cable is used for heating supply, this formula can be used to calculate the actual power P_a with the nominal voltage $U_N = 24$ VDC, the nominal power $P_N = 140$ W, the specific electrical resistance $\rho = 0.017 \Omega \text{mm}^2/\text{m}$ for copper, the length of the cable l , and the cross section of the cable A .

The heating requires an actual power P_a of higher than 125 W to operate.

The USB cable for the service interface should not be longer than 3 m.

For **rain[e]H** applies: $P_a > 125$ W and $P_N = 140$ W; for **rain[e]400H** and **rain[e]314H** applies: $P_a > 187$ W and $P_N = 210$ W

6.5 System start

The device starts automatically as soon as the sensor cable is connected. After ~15 s the device is ready for operation and starts measuring and sending data to a connected data logger according to the device configurations.

Overview status LED (centered on the main board, underneath the protective plate):	
System start	Permanent lighting of the LED for approx. 3 seconds
In operation	Fast flashing of the LED

6.6 Available interfaces

The rain[e] provides the following outputs:

Pulse output:

- 1 galvanically isolated open collector output and
- 1 non-isolated open collector output

selectable as

- Pulse output
 - Resolution: 0.01...1 mm
 - Closing time: 10...500 ms (duty cycle of 1:1)
- Status output (heating ON / OFF; rain YES / NO)

Analog output:

- 0 / 4...20 mA
- 0...2.5 / 5 V

Serial output:

- SDI-12
- RS485 (Talker protocol, WL ASCII protocol, SDI-12 protocol)
- Modbus RTU

6.7 Factory settings (heated / unheated)

6.7.1 Factory settings rain[e], rain[e]314, rain[e]400

Id No.:

00.15184.000000 00.15184.004000 00.15184.400000 00.15184.404000
00.15184.403000 00.15184.003000

The factory settings of the rain[e] according to the standard connecting diagram are:

Galvanically isolated pulse output as pulse output

Resolution: 0.1 mm
 Closing time: 300 ms
 Duty cycle: 1:1

- Galvanically non-isolated pulse output as pulse output
 - Resolution: 0.01 mm
 - Closing time: 300 ms
 - Duty cycle: 1:1
- SDI-12 protocol activated (via SDI-12 interface, 1200 Bd)
- Analog output OFF
- Heating activated (if available)

6.7.2 Factory settings rain[e]LP

Id No.: 00.15184.010000

The factory settings of the rain[e] corresponding to the standard connection diagram are as follows:

- Galvanically isolated pulse output as pulse output
 - Resolution: 0.1 mm
 - Closing time: 300 ms
 - Duty cycle: 1:1
- Galvanically non-isolated pulse output as pulse output
 - Resolution: 0.01 mm
 - Closing time: 300 ms
 - Duty cycle: 1:1
- SDI-12 protocol activated

6.7.3 Factory settings Modbus versions

Id-No.:

00.15184.400101 00.15184.000101

RS485 interface configured to Modbus RTU

Baud rate: 19200 Baud

Communication frame: 8E1 (1 start bit, 8 data bits, 1 parity bit (even parity), 1 stop bit)

6.8 Terminal assignment



All unused wires must be connected to unused pins or insulated to avoid malfunctions.

The following wiring diagrams illustrate the pin assignment of the rain[e] versions with 8-pin plug for the corresponding quick configurations in the rain[e] Commander configuration software.

To document your own assignment, we provide you with an empty connection diagram at the end of this user manual.

WIRING DIAGRAM WITH HEATING

ID-NO. 00.15184.400000, 00.15184.404000, AND 00.15184.403000

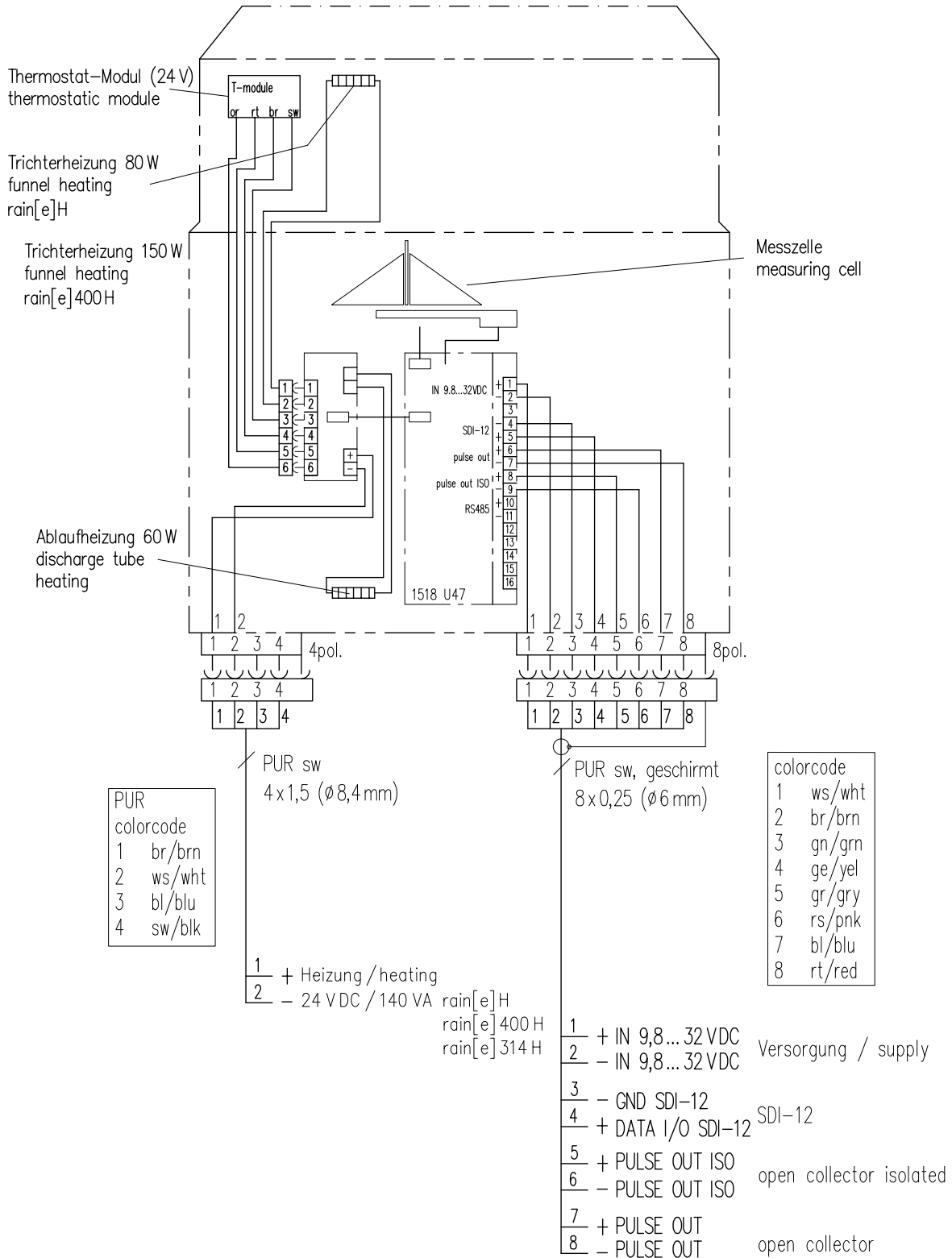

Fig. 11 a

WIRING DIAGRAM WITHOUT HEATING

ID-NO. 00.15184.000000, 00.15184.004000, AND 00.15184.003000

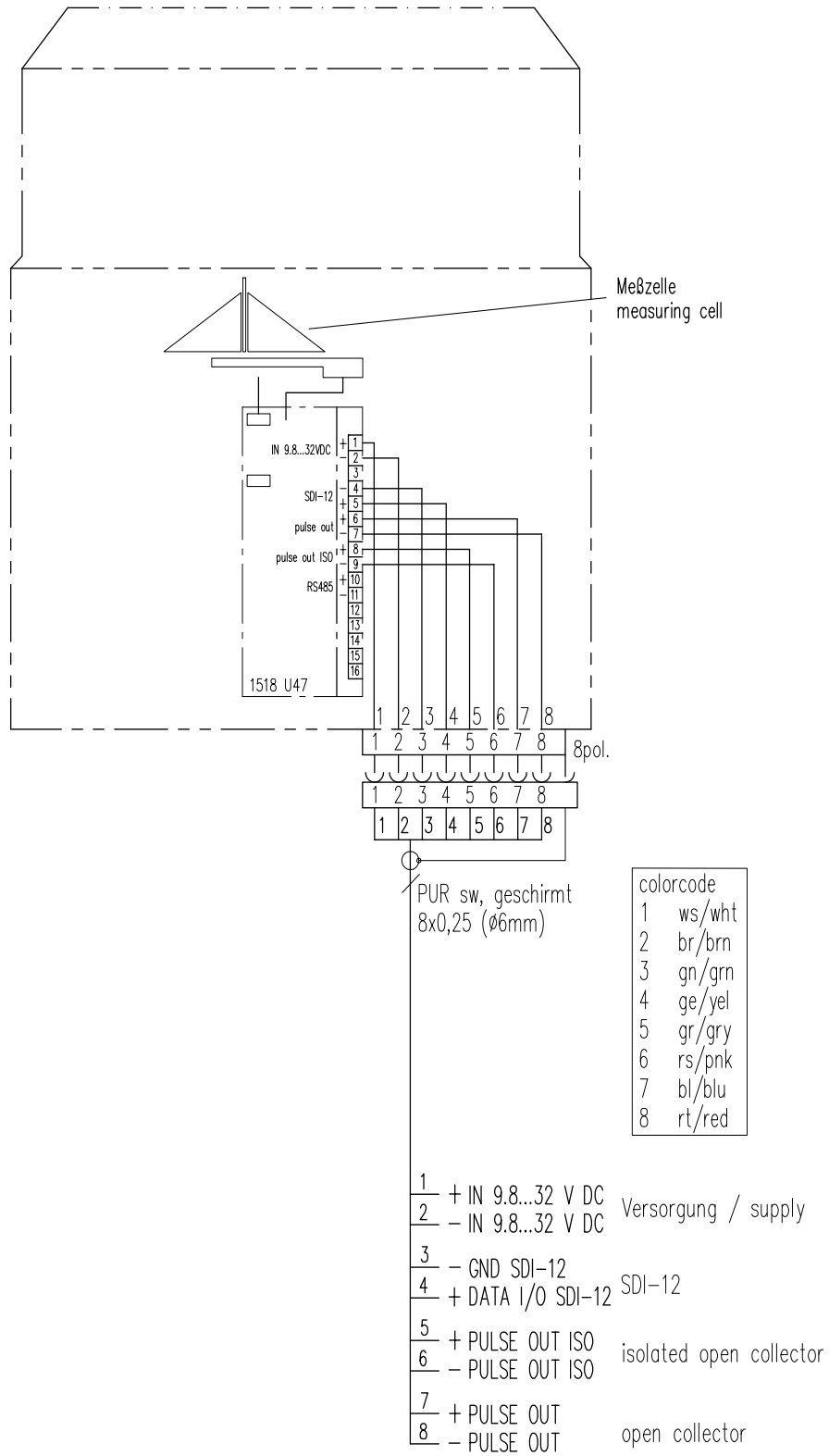

Fig. 11 b

WIRING DIAGRAM WITHOUT HEATING / MODBUS / 4-PIN PLUG

ID-NO. 00.15184.000101

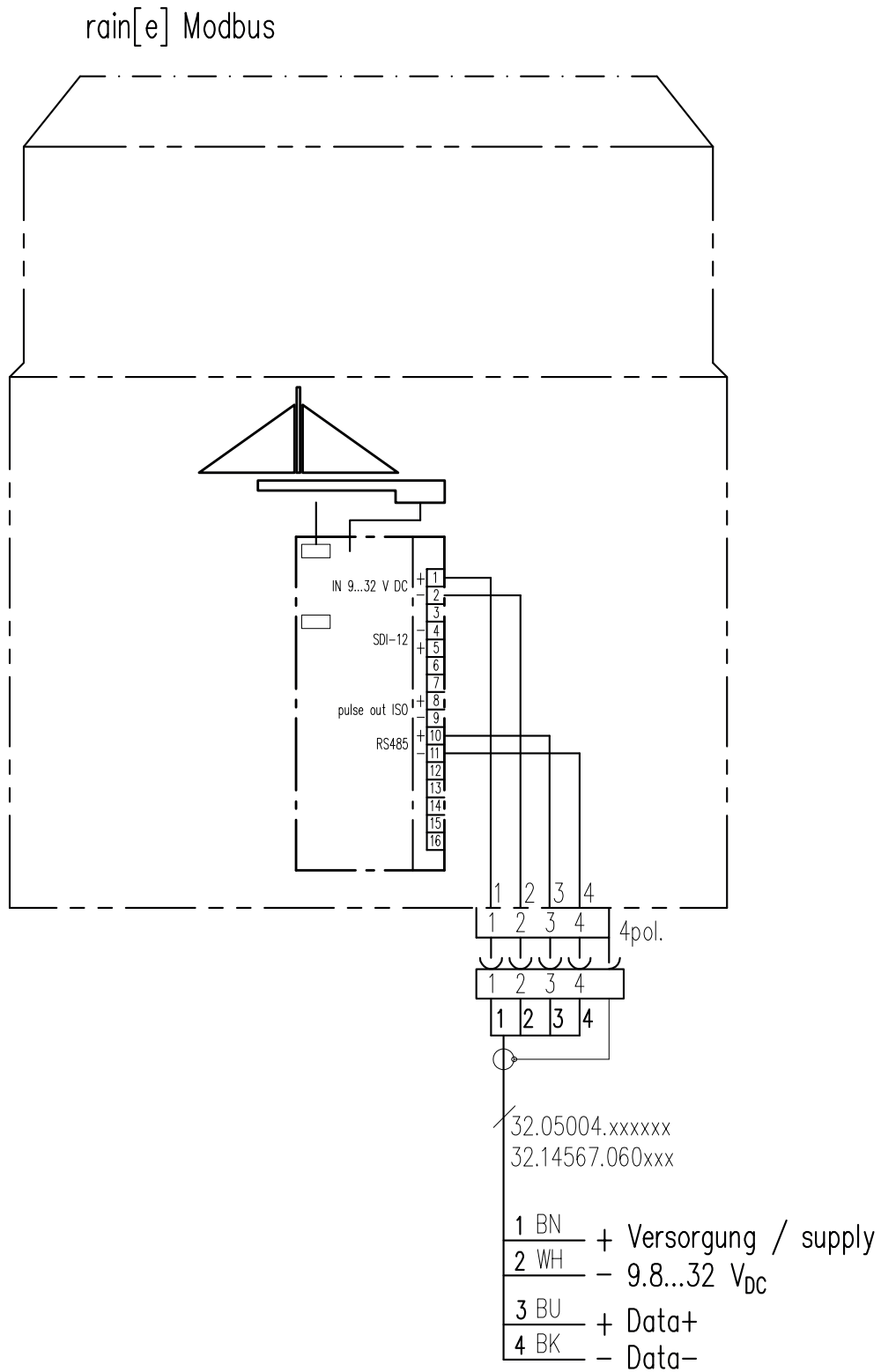

Fig.12

WIRING DIAGRAM WITH HEATING / MODBUS / 4-PIN PLUG

ID-NO. 00.15184.400101

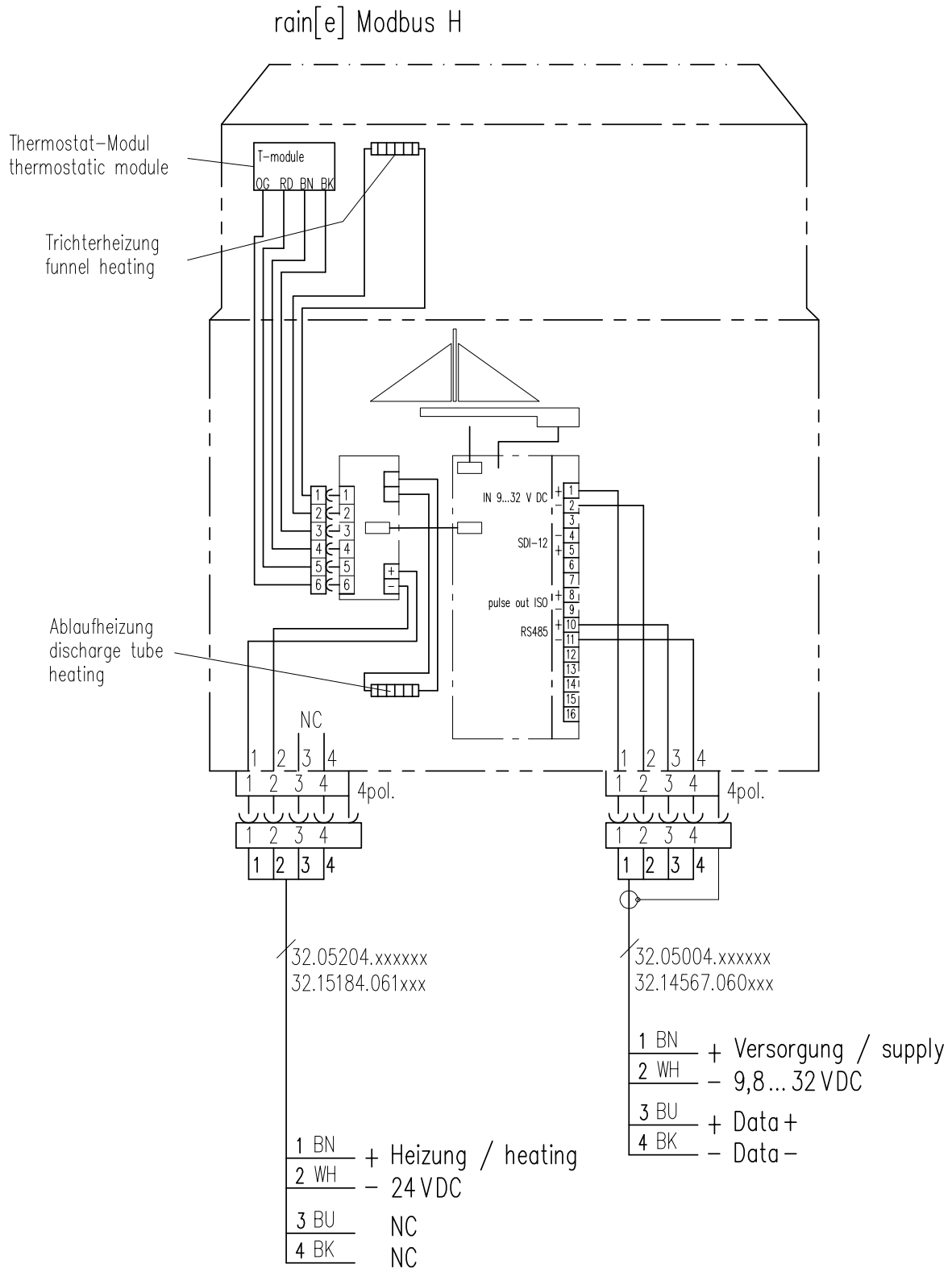

Fig. 13

WIRING DIAGRAM WITHOUT HEATING / 5-PIN PLUG

ID-NO. 00.15184.010000

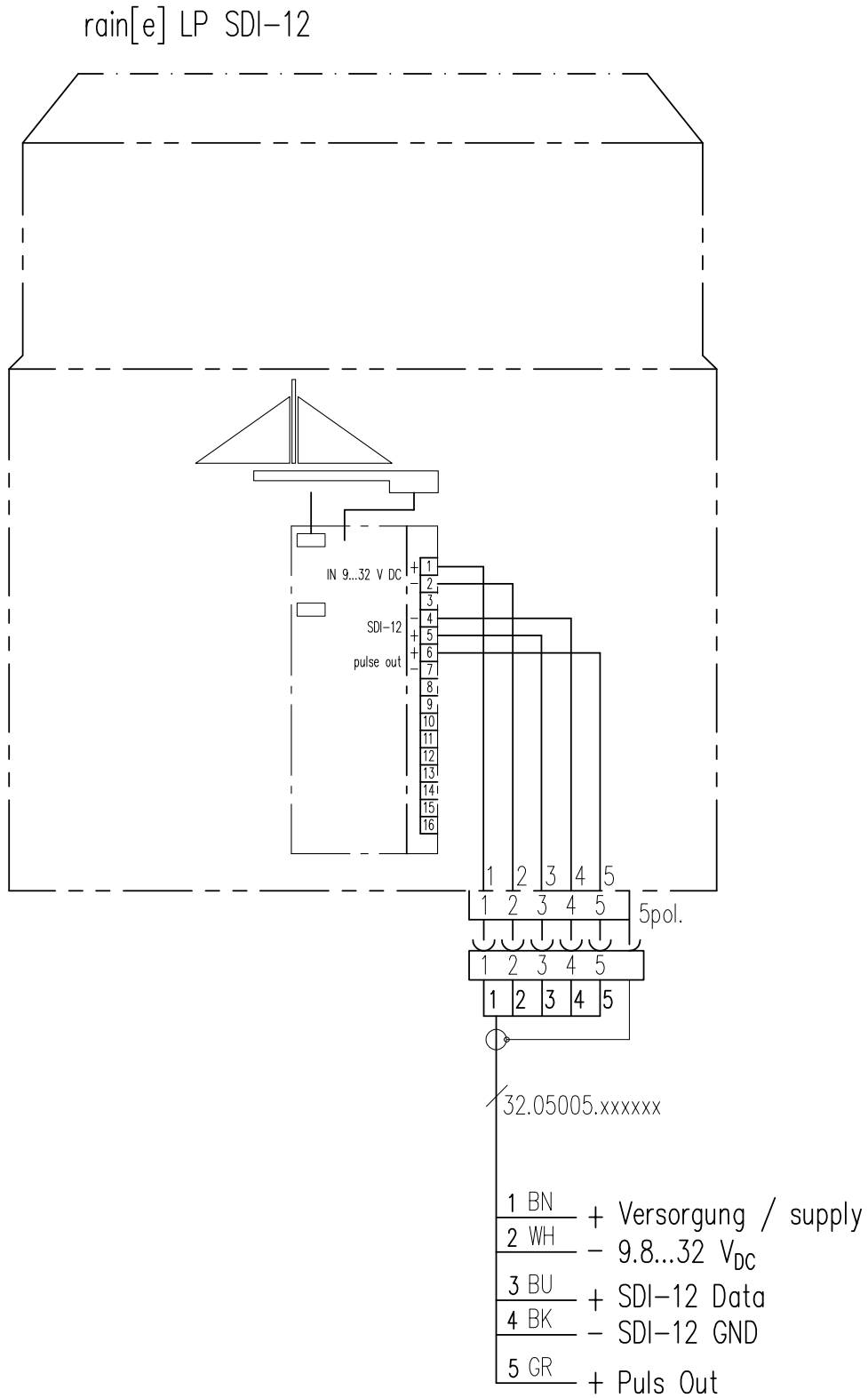

Fig.14

WIRING DIAGRAM FOR QUICK CONFIGURATION "ANALOG OUTPUT 4...20 MA"

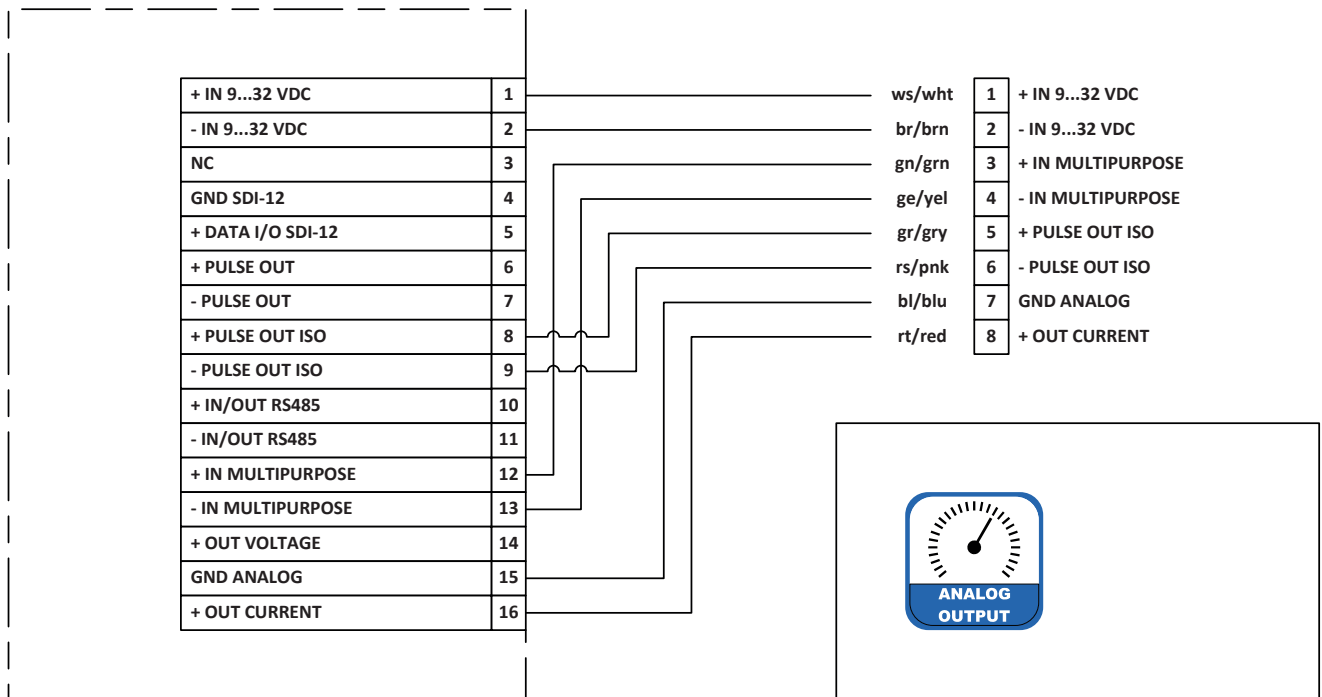

Fig.15

WIRING DIAGRAM FOR QUICK CONFIGURATION "ANALOG OUTPUT 0...2.5 V"

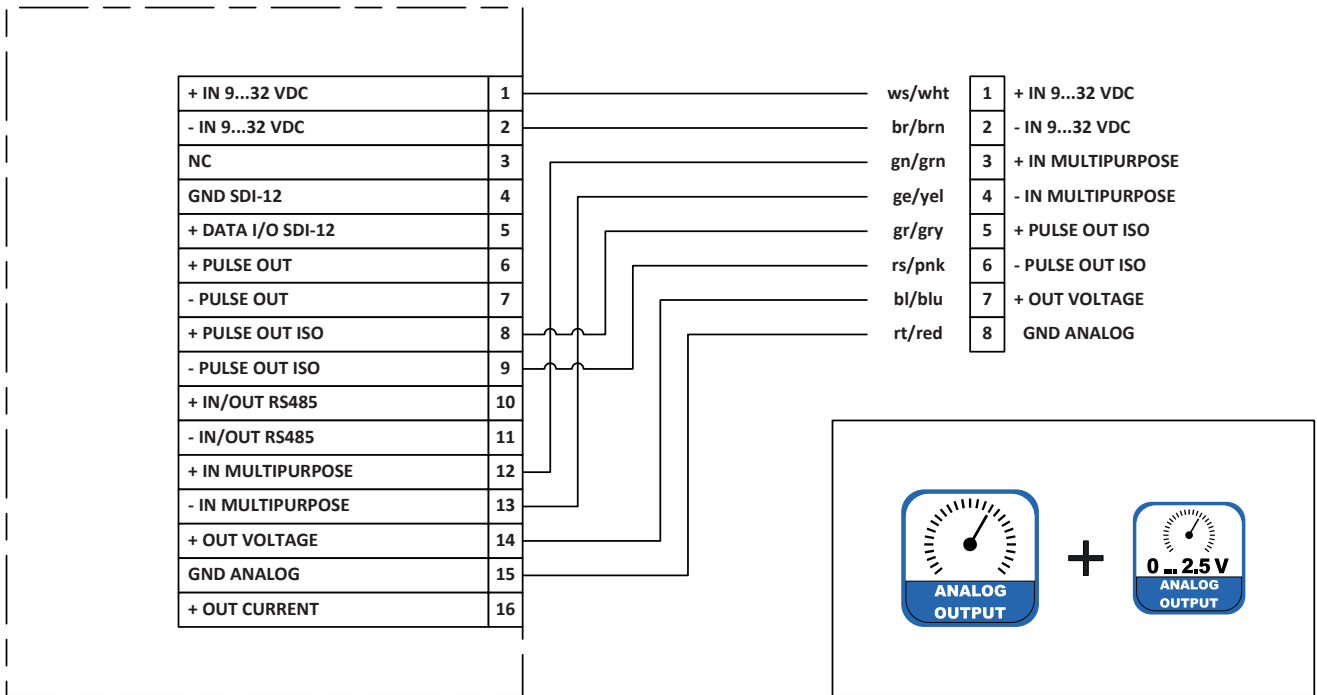

Fig.16

WIRING DIAGRAM FOR QUICK CONFIGURATION "ANALOG 4...20 MA / DIGITAL OUTPUT + RS485"

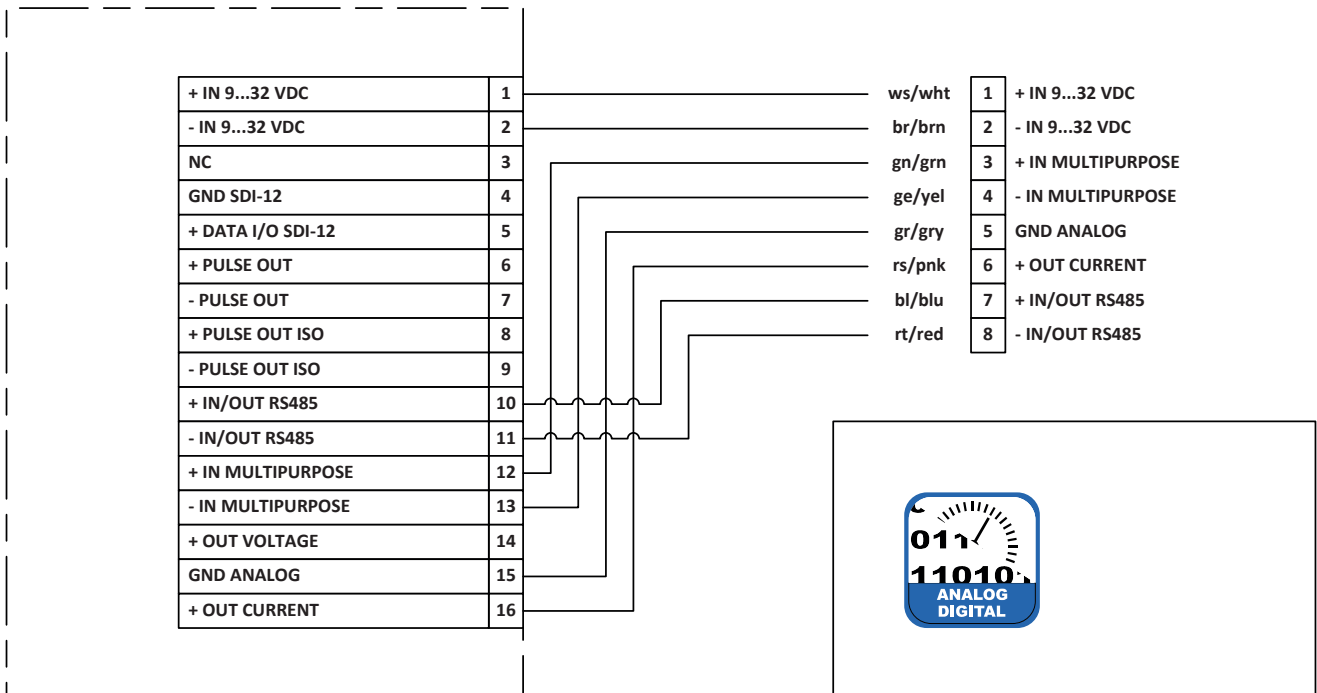

Fig.17

WIRING DIAGRAM FOR QUICK CONFIGURATION "ANALOG 0...2.5 V / DIGITAL OUTPUT"

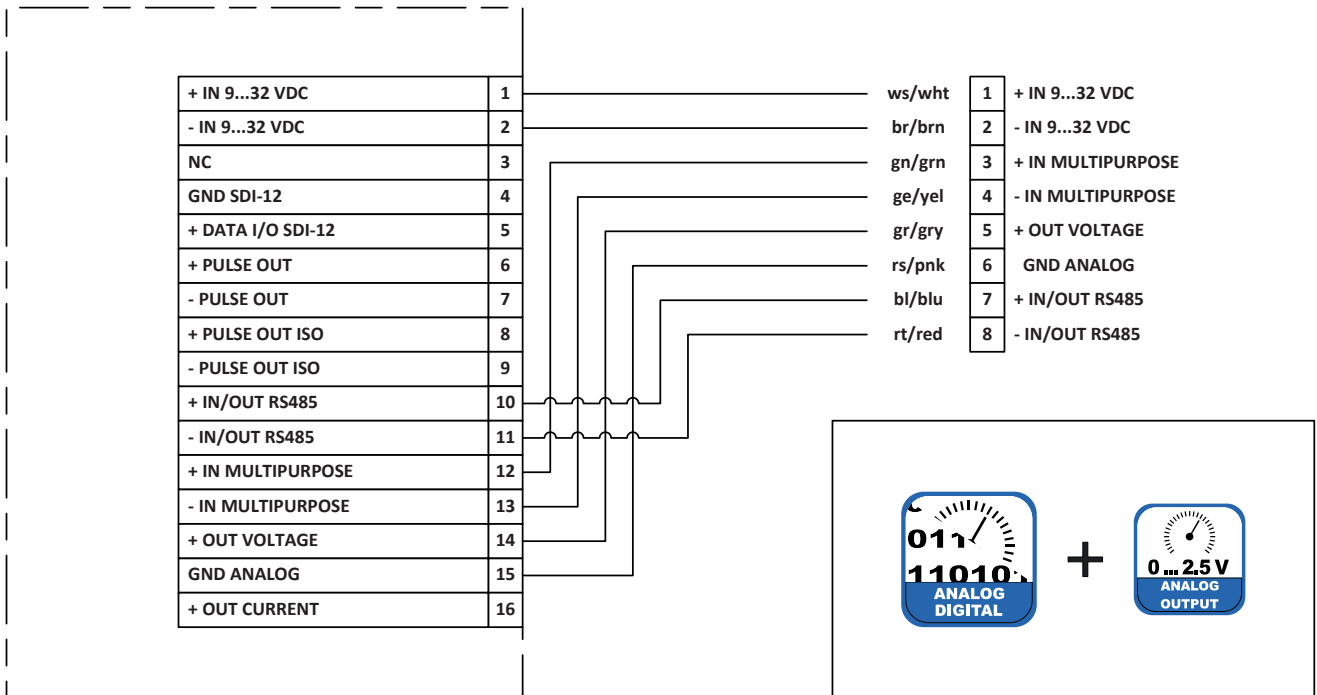

Fig.18

WIRING DIAGRAM FOR QUICK CONFIGURATION "PULSE OUTPUT"

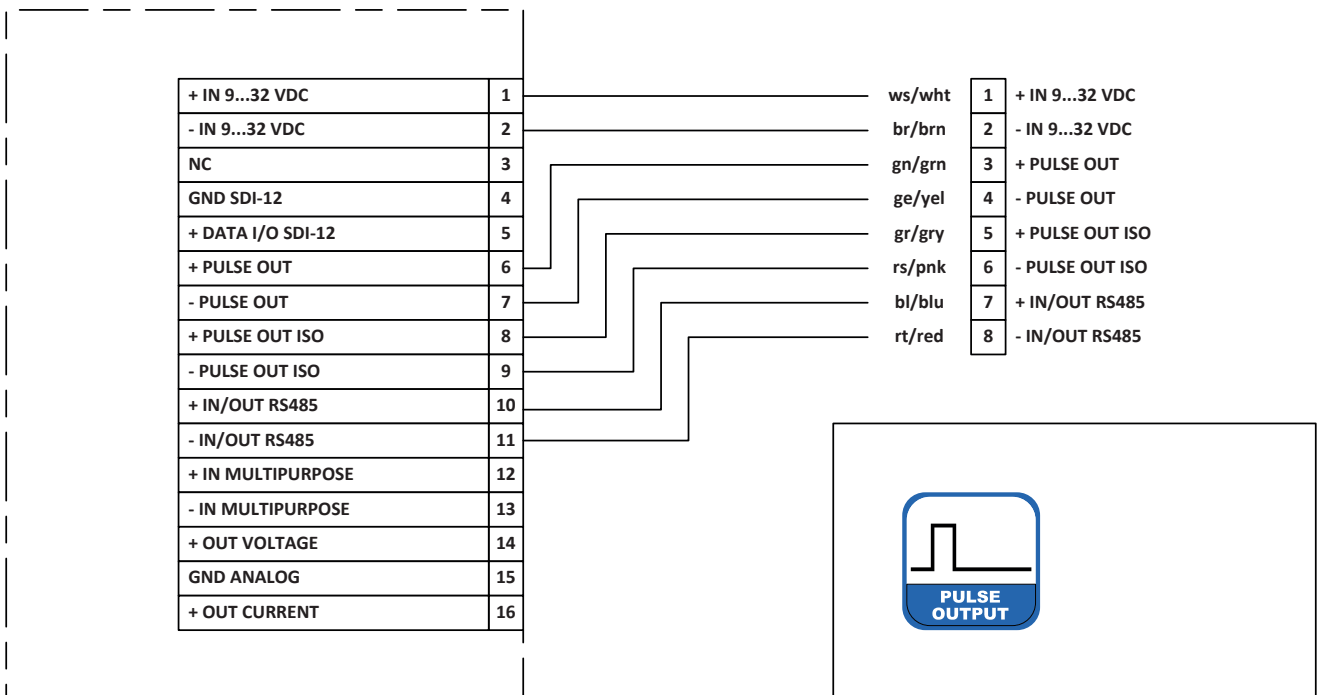

Fig.19

7 Configuration software rain[e] Commander



The rain[e] Commander is the configuration tool of the rain[e]. It can be used to configure the output signals of the rain[e]. Furthermore the load cell can be adjusted with the help of a reference weight. The software also has an update function for the rain[e] firmware and a diagnosis function to control the readiness for use of the rain[e] (see Fig. 20). To configure the rain[e] it has to be connected via the USB service interface in the device interior to a PC with installed rain[e] Commander.



It is recommended that the power plug and the sensor connector are unplugged before opening the rain[e] case to prevent it from mismeasuring. In addition, please use the “service function”, if your data logger has one.

Fig. 20

rain[e] Setup

When entering the setup area it requests that the user first selects the COM port to which the rain[e] is connected (from the drop-down menu) and retrieve the settings from the rain[e] (gear wheel icon). After retrieving the data from the rain[e] the setup screen shows the product ID, serial number, hardware revision, and firmware version of the device. In the “Quick Configuration” section the program provides buttons for the most common combination to configure the rain[e] with a few clicks. The “Expert Configuration” section allows to customise the output signals in any desired way.

QUICK CONFIGURATION

To configure the rain[e] with the “Quick Configuration” screen click on the buttons representing the desired options and sub-options. After each selection the changes will be send to the rain[e]. The output field shows the current rain[e] settings. It will be updated automatically after sending new settings to the rain[e].

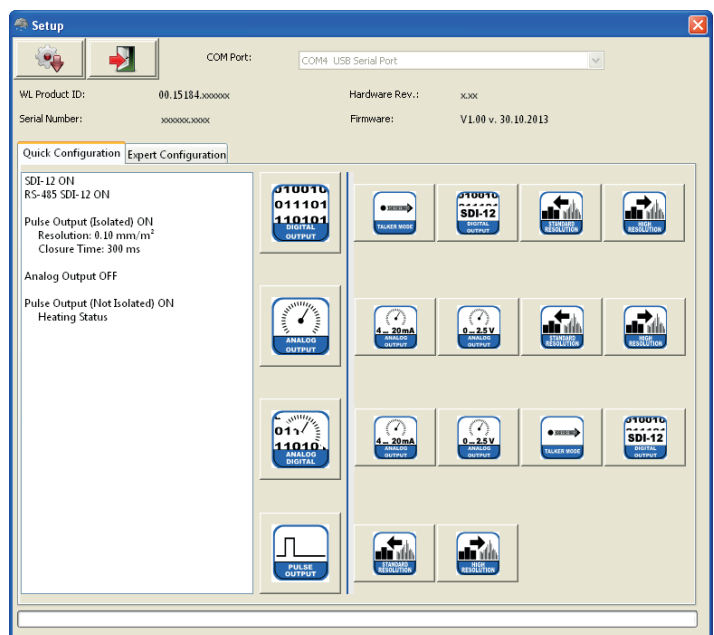

Fig. 21

Following are the respective settings listed which will be implemented by the quick configuration buttons. For the buttons of the sub-options only the changes are listed



ANALOG OUTPUT

SDI-12	ON
RS485	SDI-12 ON
Pulse Output (isolated)	ON
Operating Mode	Pulse
Resolution	0.10 mm/m ²
Closing Time	300 ms
Analog Output	ON
Effective Range	4...20 mA
Scale	20 mm/m ²
Pulse Output (not isolated)	ON
Operating Mode	Heating ON / OFF

- 4...20 mA

Analog Output	ON
Effective Range	4...20 mA
Scale Maximum	200 mm/m ²
- 0...2.5 V

Analog Output	ON
Effective Range	0...2.5 VDC
Scale Maximum	200 mm/m ²



- Standard resolution

Pulse Output (not isolated)	ON
Operating Mode	Pulse
Resolution	0.10 mm/m ²
Closing Time	300 ms



- High Resolution

Pulse Output (not isolated)	ON
Operating Mode	Pulse
Resolution	0.01 mm/m ²
Closing Time	10 ms



ANALOG / DIGITAL OUTPUT

SDI-12	ON
RS485	SDI-12 ON
Pulse Output (isolated)	ON
Operating Mode	Pulse
Resolution	0.10 mm/m ²
Closing Time	300 ms

Analog Output ON
 Effective Range 4...20 mA
 Scale 20 mm/m²
 Pulse Output (not isolated) ON
 Operating Mode Heating ON / OFF



- 4...20 mA
 Analog Output ON
 Effective Range 4...20 mA
 Scale Maximum 200 mm/m²



- 0...2.5 V
 Analog Output ON
 Effective Range 0...2.5 VDC
 Scale Maximum 200 mm/m²



- Talker Mode
 SDI-12 AUS
 RS485 Talker ON
 Talker Interval 10 s



- SDI-12 Digital Output
 SDI-12 ON
 RS485 SDI-12 ON

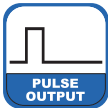

PULSE OUTPUT

SDI-12 OFF
 RS485 ASCII ON
 Pulse Output (isolated) ON
 Operating Mode Pulse
 Resolution 0.10 mm/m²
 Closing Time 300 ms
 Analog Output OFF
 Pulse Output (not isolated) ON
 Operating Mode Heating ON / OFF



- Standard Resolution
 Pulse Output (isolated) ON
 Resolution 0.10 mm/m²
 Closing Time 300 ms



- High Resolution
 Pulse Output (isolated) ON
 Resolution 0.01 mm/m²
 Closing Time 10 ms

EXPERT MODE

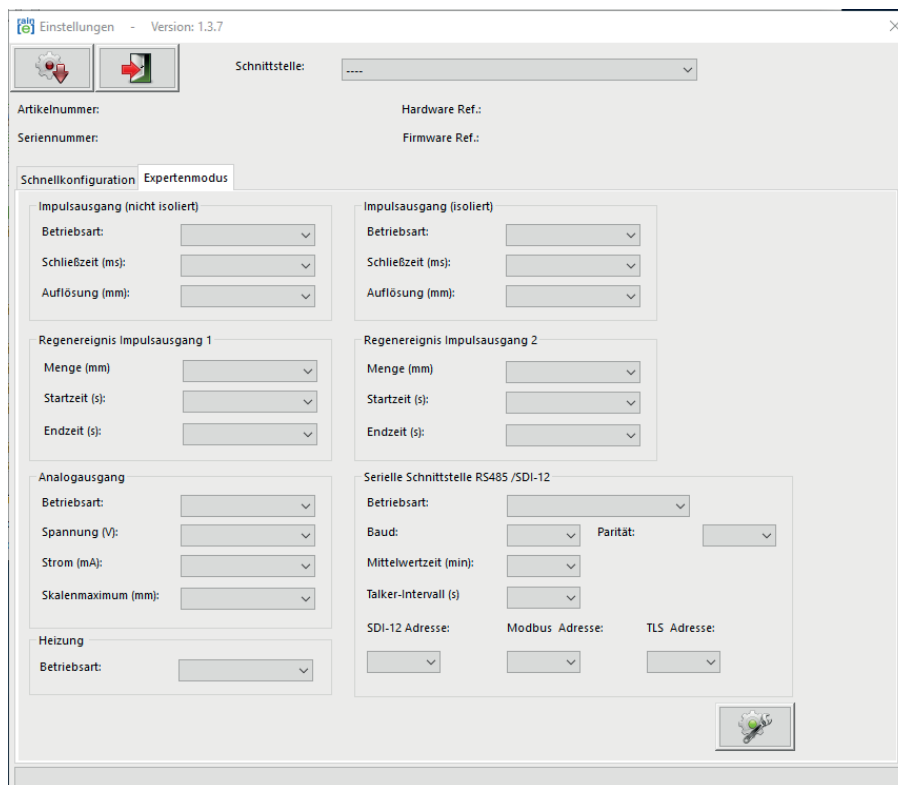

Fig. 22

The Expert Configuration screen (Fig. 22) is an easy to use tool to completely customise the configuration of the rain[e] output signals. Options are visible depending on the selected output modes. The following list shows the available options, sub-options, and value ranges.

Pulse Output (not isolated) / (isolated)

- Operating Mode
 - Impulse
 - ▶ Closing Time 10...500 ms in steps of 5 ms
 - ▶ Resolution 0.01...1 mm in steps of 0.01 mm
 - Rain YES / NO
 - ⇒ Precipitation Event (Pulse Output 1) / (Pulse Output 2)
 - ▶ Amount 0.10...1 mm steps of 0,10 mm
 - ▶ Start Time 20...60 s in steps of 1 s
 - ▶ End Time 20...600 s in steps of 1 s
 - Heating ON / OFF

Analog Output

- Operating Mode
 - Voltage 0...2.5 / 5 V
 - Current 0 / 4...20 mA
 - Scale Maximum 1...200 mm/m² in steps of 1 mm/m²

Heating - Operation Mode

ON / OFF

Serial Port (RS485)

- Operating Mode
 - WL ASCII
 - ▶ Average Time 1...60 min in steps of 1 min
 - SDI-12
 - ▶ Average Time 1...60 min in steps of 1 min
 - Talker
 - ▶ Average Time 1...60 min in steps of 1 min
 - ▶ Talker Interval 10...60 s in steps of 1 s
 - Modbus RTU

SDI-12 Address 0...9, A...Z, a...z
 Modbus Address 0...247

LOAD CELL ADJUSTMENT

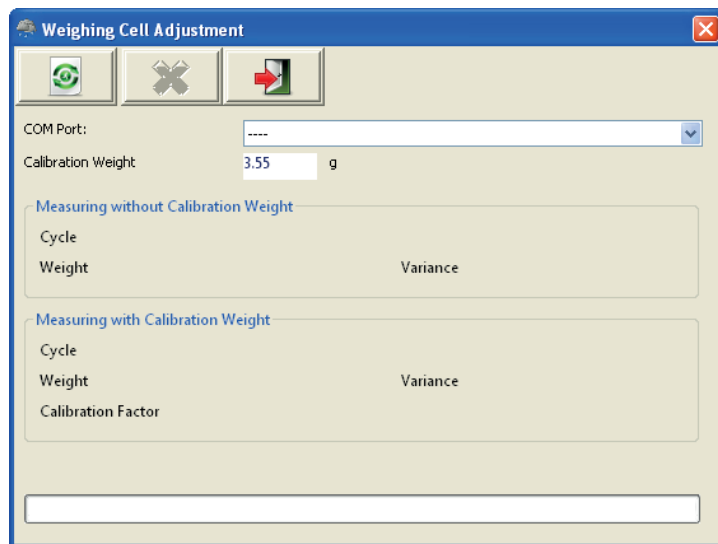

Fig. 23

The “**Load Cell Adjustment**” screen (Fig. 23) may be used to adjust the load cell. It will give the number of cycles the program has carried out, the mean value of the measured weight, and the variance of the values. If a calibration weight is used, a calibration factor will be given.

To adjust the load cell first select the COM port of the rain[e] from the drop-down menu. If desired, put a calibration weight in the collecting vessel and enter the weight into the corresponding text box. To start the adjustment click the green “**Start Adjustment**” button.

Pressing the button with the red “**X**” will stop the running adjustment.

Adjustment has to done again if the deviations in the diagnostics are higher than ± 30 mg.

FIRMWARE UPDATE

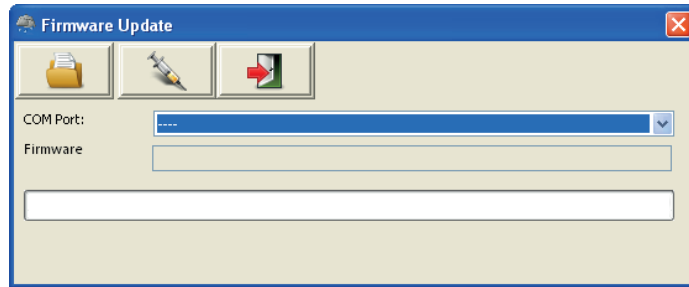

Fig. 24

If an update or modification of the firmware is needed e.g new features are available or the requirements of the output signals have changed, you shall receive a firmware file via e-mail. To update your rain[e] firmware use the “**Firmware Update**” screen (Fig. 24). Select the COM port of the connected rain[e] from the drop-down menu, click “**Browse for Firmware File**” (folder icon) and select the firmware file on your computer or tablet. Then click “**Load Firmware**” to rain[e] (syringe icon).

DIAGNOSTICS

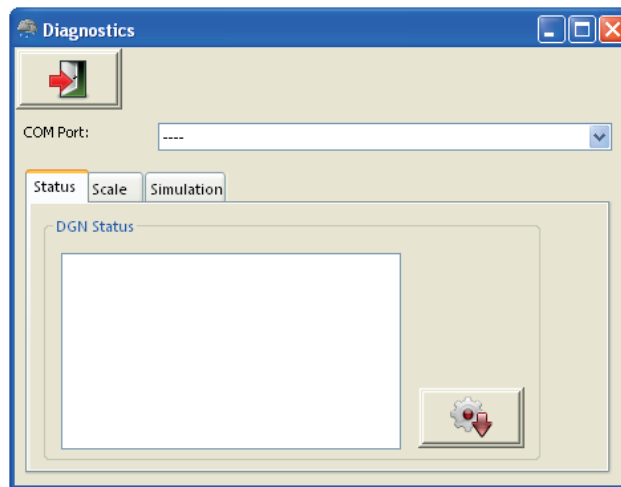

Fig. 25

The “**Diagnostics**” mask is divided into three tabs: “**Status**” - to check the system status, “**Scale**” - to test the load cell and “**Simulation**” - to simulate precipitation amounts to check the output signals of the impulse and analog outputs (Fig. 25). To use any of these functions the COM port of the connected rain[e] has to be selected from the drop-down menu.

To check the system status one has to click “**Retrieve rain[e] Status**” (gear wheel icon) in the tab “**Status**”. The program will return the following status message:

Heating Temperature - OK / Malfunction	Not exceeding the heating temperature by 10 °C
Heating Test - OK / Malfunction	Working Heating
Temperature Sensor Bottom - OK / Malfunction	Working Temperature Sensor Bottom
Temperature Sensor Top - OK / Malfunction	Working Temperature Sensor Top
Status 6-9	Internal use only

To test the weighing scale one has to put a (known) weight into one pan of the collecting vessel and click “**Test Scale**” (blue gear wheel icon) in the tab “**Scale**”.

To simulate precipitation amounts to check the output signals of the pulse and analog outputs, one has to select the desired amount from the drop-down menu in the tab “**Simulation**” and click “**Simulate Precipitation**” (cloud icon). The analog and pulse outputs will return signals according to the applied settings in the rain[e] Setup.

8 Input and Output

The following chapter describes the available analog, digital and, serial interfaces and their protocols. Depending on the sensor version different interfaces are available:

Id-No.	Description	RS485	SDI-12	Analog	Pulse (Digital)	Default Protocol
00.15184.000000	rain[e]	X	XX	X	XX	SDI-12
00.15184.400000	rain[e]H	X	XX	X	XX	SDI-12
00.15184.403000	rain[e]314H	X	XX	X	XX	SDI-12
00.15184.003000	rain[e]314	X	XX	X	XX	SDI-12
00.15184.404000	rain[e]400H	X	XX	X	XX	SDI-12
00.15184.004000	rain[e]400	X	XX	X	XX	SDI-12
00.15184.400101	rain[e]one H Modbus	XX	X	X	X	Modbus
00.15184.000101	rain[e]one Modbus	XX	X	X	X	Modbus
00.15184.010000	rain[e]LP	-	XX	-	XX	SDI-12

H = heated; XX = default; X = available, requires rewiring, and configuration; - = not available

8.1 SDI-12 Interface

The communication using SDI-12 protocol via SDI-12 interface is based on the “SDI-12 A Serial-Digital Interface Standard for Microprocessor-Based Sensors, Version 1.3, 2012”. The rain[e] can be used in bus mode parallel to other rain[e].

The following subset of SDI-12 commands were implemented into the rain[e]. For further details to the SDI-12 protocol we recommend the afore-mentioned standard document or the website www.SDI-12.org.

IMPLEMENTED SDI-12 COMMANDS:

Command	Function	Answer of the sensor
a!	Acknowledge Active	a<CR><LF>
?!	Address Query Command	a<CR><LF>
a!	Send Identification	allccccccmmmmmmvvvxx...xx<CR><LF>
aAb!	Change Address	b<CR><LF>
aM!	Start Measurement	atttn<CR><LF>
aMC!	Start Measurement and Request CRC	atttn<CR><LF>
aC!	Start Concurrent Measurement	atttn<CR><LF>
aCC!	Start Concurrent Measurement and Request CRC checksum	atttn<CR><LF>
aD0!	Send Data (Puffer 0)	a<Werte><CR><LF>
aD1!	Send Data (Puffer 1)	a<Werte><CRC><CR><LF>
aM1!	Generate Variance	atttn<CR><LF>
aM2!	Generate Heating Data	atttn<CR><LF>
aM3!	Start Intensity Measurement Average Value, Maximum and Minimum	atttn<CR><LF>
aMC1!	Generate Variance and Request CRC	atttn<CR><LF>
aMC2!	Generate Heating Data and Request CRC	atttn<CR><LF>
aMC3!	Start Intensity Measurement Average Value, Maximum and Minimum and Request CRC	atttn<CR><LF>
aC1!	Generate Variance	atttn<CR><LF>
aC2!	Generate Heating Data	atttn<CR><LF>
aC3!	Start Intensity Measurement Average Value, Maximum and Minimum	atttn<CR><LF>
aCC1!	Generate Variance and Request CRC	atttn<CR><LF>
aCC2!	Generate Heating Data and Request CRC	atttn<CR><LF>
aCC3!	Start Intensity Measurement Average Value, Maximum and Minimum and Request CRC	atttn<CR><LF>
aV!	Start Verification	atttn<CR><LF>

a = address of the respective sensor; standard sensor address = 0

SDI-12 commands always start with the address of the appropriate sensor. Therefore all other sensors on the same bus will ignore these commands. SDI-12 commands end with "!". All answers from sensors start with its address, too, but end with the ASCII characters "Carriage Return" <CR> and "Line Feed" <LF>.

The SDI-12 protocol is based on the ASCII character set. The baud rate of the SDI-12 protocol is 1200 Bd and has the byte frame format:

- 1 start bit
- 7 data bits (least significant bit first)
- 1 parity bit (even parity)
- 1 stop bit

Acknowledge Active - a!

This command ensures that the sensor responds to requests from the master. Basically it asks the sensor to confirm it is connected to the bus.

The sensor returns its address and **<CR><LF>**.

Syntax

Command	Answer
a! a – Sensor adresse ! – End of command	a<CR><LF> a – Sensor address <CR><LF> – End of answer

Example:

Command	Answer
0!	0<CR><LF>
1!	1<CR><LF>

Send Identification - a!

The command **a!** is used to ask the sensor for its model number and firmware version.

Syntax

Command	Answer
a! a – Sensor address ! – Command "Send Identification"	a 13LMGmbH1515184x1.0781129.0001<CR><LF> a – Sensor address 13LMGmbH1515184x1.0781129.0001 13 – 2 characters SDI-12 version no. 13 = version 1.3 LMGmbH15 – 8 characters manufacturer's name (= Lambrecht meteo GmbH) 15184x – 6 characters sensor type (= precipitation sensor rain[e]) 1.0 – Sensor version (= version 1) 781129.0001 – 11 characters serial no. <CR><LF> – End of answer
! – End of command	

Example:

Command	Answer
0!	013LMGmbH1515184x1.0781129.0001<CR><LF>
1!	113LMGmbH1515184x1.0781129.0002<CR><LF>

Change Address - aAb!

The factory setting of the address is "0". If there are several sensors connected to one bus, the sensor address can be changed with the command **aAb!**. The address is always a single ASCII character. Standard for addresses are the ASCII characters "0" to "9" (decimal 48 to 57). If there are more than 10 sensors connected to one bus, using the characters "A" to "Z" (decimal 65 to 90) and "a" to "z" (decimal 97 to 122) is allowed. The sensor answers with its new address and **<CR><LF>**. After the address is changed, one should not send further commands to the sensor for a period of one second (see also "SDI-12 Standard, Version 1.3, 2012").

Syntax

Command	Answer
aAb! a – Old sensor address A – Command “Change Address” b – New sensor address ! – End of command	b<CR><LF> b – New sensor address <CR><LF> – End of answer

Example:

Command	Answer
0A1!	1<CR><LF>

Start Measurement - aM!

The command **aM!** requests that the sensor processes the returning string and provide the available measured data. In contrast to standard sensors described in the SDI-12 documentation the rain[e] measures continuously. Thus the measured values from the continuous measurement are stored in a buffer while the string is being processed. These values are processed after the string processing. Therefore the rain[e] always responds with “a003x”. This is also the reason why the rain[e] does not send a “Service Request” and ignores signals to interrupt the measurement. Prior to the returned waiting time (3 s) the data logger must not send further commands. After expiration of the waiting time the data can be requested with the commands **aD0!** and **aD1!** (see **Send Data**). The data will not be overwritten until the next **C**, **M**, or **V** command and can be read several times until then.

Syntax

Command	Answer
aM! a – Sensor address M – Command “Start Measurement” ! – End of command	a0036<CR><LF> a – Sensor address 003 – Seconds the sensor needs until the measured data can be returned (= 3 s) 06 – Number of provided measured data <CR><LF> – End of answer

Example:

Command	Answer
1M!	10036<CR><LF>

The measured data can be requested with the commands **aD0!** and **aD1!**. (see **Send Data**).

Start Measurement and Request CRC - aMC!

Same command as **aM!** but in addition to the generated data the sensor returns a 3-digit CRC checksum. For information on how the CRC checksum is generated, please consult "SDI-12 Standard, Version 1.3, 2012, chapter 4.4.12".

Syntax

Command	Answer
aMC! a – Sensor address M – Command "Start Measurement and Request CRC" C – Request for transmission of the CRC checksum ! – End of command	a0036<CR><LF> a – Sensor address 003 – Seconds the sensor needs until the measured data can be returned (= 3s) 6 – Number of provided measured data <CR><LF> – End of answer

Example:

Command	Answer
2MC!	20036<CR><LF>

Start Concurrent Measurement - aC!

The **Concurrent Measurement** enables the data logger to measure simultaneously with multiple rain[e] on the same bus. The command **aC!** requests that the sensor process the returned string and to provide the available measured data. In contrast to standard sensors described in the SDI-12 documentation, the rain[e] measures continuously. Thus the values during continuous measuring are stored in buffer while the string is being processed. These values are processed after the string processing. Prior to the return waiting time (3 s) the data logger must not send further commands. After expiration of the waiting time the data can be requested with the commands **aD0!** and **aD1!** (see **Send Data**).

The data will not be overwritten until the next **C**, **M**, or **V** command and can be read several times in the meantime.

Syntax

Command	Answer
aC! a – Sensor address C – Command "Start Concurrent Measurement" ! – End of command	a00306<CR><LF> a – Sensor address 003 – Seconds the sensor needs until the measured data can be returned (= 3 s) 6 – Number of provided measured data <CR><LF> – End of answer

Example:

Command	Answer
2C!	200306<CR><LF>

The measured data can be requested with the commands **aD0!** and **aD1!** (see **Send Data**).



Start Concurrent Measurement with CRC - aCC!

Same command as **aC!** but in addition to the generated data the sensor returns a 3-digit checksum. For information on how the CRC checksum gets generated, please consult "SDI-12 Standard Version 1.3, 2012, chapter 4.4.12".

Syntax

Command	Answer
aCC! a - Sensor address C - Command "Start Concurrent Measurement" C - Request for transmission of the CRC checksum ! - End of command	a00306<CR><LF> a - Sensor address 003 - Seconds the sensor needs until the measured data can be returned (= 3 s) 06 - Number of provided measured data <CR><LF> - End of answer

Example:

Command	Answer
2CC!	200306<CR><LF>

Send Data - aD0! and aD1!

Data generated by the commands **C**, **M**, or **V** are requested from the sensor with **aD0!** and **aD1!**. The sensor uses the respective arithmetic sign ("+" or "-") to separate the values. If the data was requested with a **CC** or **MC** command, it will be returned with the CRC checksum. For information on how the CRC checksum gets generated, please consult "SDI-12 Standard Version 1.3, 2012, chapter 4.4.12".

The measured data is returned in metric units.

Measured data	Unit
Buffer 0	
Precipitation intensity within the last minute	mm/min
Precipitation intensity within the last minute in mm/h	mm/h
Precipitation intensity since last request	mm/min

Measured data	Unit
Buffer 1	
Precipitation intensity since last request in mm/h	mm/h
Precipitation amount since last request	mm/m ²
Precipitation amount total *	mm/m ²

* see also chapter 8.3 for the evaluation of the total precipitation quantity

Syntax for measurements with “aC!” or “aM!” command

Command	Answer
aDO! a – Sensor address D – Command “Send Data” 0 – Request for the data in buffer 0 or 1 = buffer 1 ! – End of command	a<values><CR><LF> a – Sensor address <values> – Requested data separated by corresponding sign (“+” or “-”) <CR><LF> – End of answer

Example:

Command	Answer
0C!	000306<CR><LF>
0D0!	0+0.100+6.000+0.100<CR><LF>
0D1!	0+6.000+12.000+25.231<CR><LF>

Syntax for measurements with aCC! or aMC!

Command	Answer
aDO! a – Sensor address D – Command “Send Data” 0 – Request for the data in buffer 0 or 1 = buffer 1 ! – End of command	a<values><CRC><CR><LF> a – Sensor address <values> – Requested data separated by corresponding sign (“+” or “-”) <CRC> – 3–digit CRC checksum <CR><LF> – End of answer

Additional measurement options

With the following commands additional information can be generated by the rain[e] and requested with **aD0!**. The additional measurement commands **aMn!** and **aMCn!** have the same format as the commands **aM!** and **aMC!**. The same applies to the commands **aCn!** and **aCCn!** which have the same format as **aC!** and **aCC!**.

n	Function	Command	Answer										
1	Generation of the variance (period 4 s)	aM1!	a0031<CR><LF>										
		aC1!	a00301<CR><LF>										
		with CRC checksum	aMC1!	a0031<CR><LF>									
		aCC1!	a00301<CR><LF>										
2	Generation of the heating data <table border="1" style="width: 100%; border-collapse: collapse;"> <thead> <tr> <th>Measured variable</th> <th>Unit</th> </tr> </thead> <tbody> <tr> <td>Buffer 0</td> <td></td> </tr> <tr> <td>Temperature interior</td> <td>°C</td> </tr> <tr> <td>Heating ON (1) / OFF (0)</td> <td></td> </tr> <tr> <td>Heating power total</td> <td>%</td> </tr> </tbody> </table>	Measured variable	Unit	Buffer 0		Temperature interior	°C	Heating ON (1) / OFF (0)		Heating power total	%	aM2!	a0033<CR><LF>
		Measured variable	Unit										
		Buffer 0											
		Temperature interior	°C										
		Heating ON (1) / OFF (0)											
		Heating power total	%										
aC2!	a00303<CR><LF>												
mit CRC-Prüfsumme	aMC2!	a0033<CR><LF>											
aCC2!	a00303<CR><LF>												

3	Generation of the data: precipitation intensity, average value, max. / min. intensity of the last x minutes*.			aM3!	a0033<CR><LF>
	Measured variables	Unit			
	Buffer 0				
	Average value of the last x minutes*	mm/min		aC3!	a00303<CR><LF>
	Max. intensity of the last x minutes*	mm/min			
	Min. intensity of the last x minutes*	mm/min			
The default value for the period x is 10 min. The value can be changed with the rain[e] Commander (see chapter 7).			with CRC checksum	aMC3!	a0033<CR><LF>
				aCC3!	a00303<CR><LF>

* The acquisition of these values starts with the command and they have to be requested after exactly x minutes with the aD0! command.

Start Verification - aV! (Error string)

For service purposes the command **aV!** can be used to do a system analysis and generate an error string. The command **aV!** has the same format as the command **aM!** (see above). The rain[e] answers to the command **aV!** with “**a0039**”.

Syntax

Command	Answer
aV! a – Sensor address V – Command “Start Verification” ! – End of command	a0039<CR><LF> a – Sensor address 003 – Seconds the sensor needs until measured data can be returned (= 3 s) 9 – Number of provided data <CR><LF> – End of answer

Example:

Command	Answer
1V!	10039<CR><LF>

The measured data can be requested with the command **aD0!**. (see **Send Data**).

Data output	Value range
Buffer 0	
For internal use	0...99
Error due to exceeding of the heating temperature by 10° C	0 or 1
Error heating	0 or 1
Error interior temperature sensor	0 or 1
Error funnel temperature sensor	0 or 1
For internal use	0 or 1
For internal use	0 or 1
For internal use	0 or 1
For internal use	0 or 1

+0 = ok; +1 = error

The data will not be overwritten until the next **C**, **M**, or **V** command and can be read several times until then.

Remark to the SDI-12 “Break” signal

Since the rain[e] does not have a sleeping mode it does not need to be “awakened”. This means that the rain[e] ignores the “Break” command. Therefore all regulations associated to the “Break” command do not have to be considered.

8.2 RS485 Interface

These protocols are available on the RS485 interface: SDI-12 (on RS485); WL ASCII; Talker.

The usual communication settings for the SDI-12 protocol are:

Baud rate:	1200 Baud
Data bits:	7
Parity:	even
Stop bits:	1

The following communication settings apply to the other protocols:

Baud rate:	19200 Baud
Data bits:	8
Parity:	none
Stop bits:	1

8.2.1 SDI-12 Protocol

This is exactly the same protocol with the same commands as the SDI-12 protocol via SDI-12 interface (described in ch. 8.1, pp. 23 ff).

8.2.2 WL ASCII Protocol

As an alternative to the SDI-12 protocol the rain[e] can also answer with a LAMBRECHT defined ASCII protocol via the RS485 interface, too. It may be addressed every 10 s. It is recommended to work with 60 s intervals. Commands in the WL ASCII protocol start with **<STX>** “Start Text” and end with “Carriage Return” **<CR>** and ‘Line Feed’ **<LF>**. Since addressing is not possible with the WL ASCII protocol, it can only be used with a single rain[e] and not in a bus.

The baud rate is 19200 Bd and has the byte frame format 8N1:

8 data bits; no parity bit (no parity); 1 stop bit

Start Measuring <STX>m<CR><LF>

The command **<STX>m<CR><LF>** requests the sensor to process the returning string and to provide the available measured data. The rain[e] measures continuously. Thus measured values from the continuous measuring get stored into a buffer while the string is being processed. These values will be processed after the string processing. The answer is according to the syntax described below. The data fields are separated by a semicolon and the sign is always transmitted. The respective field lengths are fixed, leading non-significant digits are filled with blanks after the sign.

Syntax

Command	Answer	Number of digits (before point, after point)
<STX>m<CR><LF>	int_{min};int_h;int_{ret_min};int_{ret_h};am_{ret};am_{tot};s_{he};t_{in}<CR><LF>	
<STX> - Start of command	int_{min} - Intensity in mm/min	2.3
m - Command "Start Measuring"	int_h - Intensity in mm/h	4.3
<CR><LF> - End of command	int_{ret_min} - Average intensity since last retrieval in mm/min	2.3
	int_{ret_h} - Average intensity since last retrieval in mm/h	4.3
	am_{ret} - Amount since last retrieval in mm	4.3
	am_{tot} - Total amount * since system start in mm	4.3
	s_{he} - Heating Status (1 = ON, 0 = OFF)	1.0
	t_{in} - Temperature in °C	3.2
	<CR><LF> - End of answer	

(* see also chapter 8.3)

Example: Retrieval after 10 min with constant intensity

Command	Answer
<STX>m<CR><LF>	+ 1.059;+ 63.514;+ 1.059;+ 63.514;+ 0.164;+ 1.239;+0;+ 4.06;<CR><LF> (+12.123;+1234.123;+12.123;+1234.123;+1234.123;+1234.123;+1;+123.12;<CR><LF>)

Return Error String <STX>e<CR><LF>

For service purposes the command **<STX>e<CR><LF>** can be used to do a system analysis and generate an error string.

Syntax

Command	Answer
<STX>e<CR><LF>	1;2;3;4;5;6;7;8;9;<CR><LF>
<STX> - Start of command	1 - For internal use
e - Command "Return Error String"	2 - Error due to exceeding of the heating temperature by 10 °C
<CR><LF> - End of command	3 - Error heating
	4 - Error interior temperature sensor
	5 - Error funnel temperature sensor
	6 - For internal use
	7 - For internal use
	8 - For internal use
	9 - For internal use
	<CR><LF> - End of answer

+0 = ok; +1 = error

Example: Heating check failed

Command	Answer
<STX>e<CR><LF>	3;0;1;0;0;0;0;0;0;<CR><LF>

Return Device Information <STX>i<CR><LF>

For service purpose the command <STX>i<CR><LF> can be used to ask the sensor for its serial number, board version, software version and serial number of the load cell.

Syntax

Command	Answer
<STX>i<CR><LF>	Nr;P;S;Zelle;<CR><LF>
<STX> – Start of command	Nr – Serial No. of the device
e – Command “Return Error String”	P – Board version
<CR><LF> – End of command	S – Firmware version
	Zelle – Serial No. of the load cell
	<CR><LF> – End of answer

Example:

Command	Answer
<STX>i<CR><LF>	801456.0010;1.3v;V1.00 v. 12.11.2013;2C096/0420000000;<CR><LF>

Start Measurement Intensity <STX>a<CR><LF>

The command <STX>a<CR><LF> can be used to ask the sensor for the average, maximum and minimum intensity over a selected time frame; this time frame has to be selected in the “**Expert Configuration**” in the rain[e] Commander.

Syntax

Command	Answer
<STX>a<CR><LF>	int_{avr};int_{max};int_{mini};<CR><LF>
<STX> – Start of command	int_{avr} – Average intensity in mm/min
a – Command “Measurement Intensity”	int_{max} – Maximum intensity in mm/min
<CR><LF> – End of command	int_{mini} – Minimum intensity in mm/min
	<CR><LF> – End of answer

Example:

Command	Answer
<STX>a<CR><LF>	0.059;0.073;0.031;<CR><LF>

8.2.3 Talker protocol

The Talker protocol is the third available mode of the RS485 interface. It sends an ASCII string in a defined interval. The interval can be adjusted between 10...60 s using the rain[e] Commander.

The baud rate is 19200 Bd and has the byte frame format 8N1:

8 data bits

no parity bit (no parity)

1 stop bit

Syntax

+int_{min};+int_h;+am_{tot};+s_{he};+t_{in};+s_{sys}<CR><LF>
int_{min} – Intensity in mm/min
int_h – Intensity in mm/h
am_{tot} – Total amount * in mm
s_{he} – Status heating (1 = ON, 0 = OFF)
t_{in} – Temperature in °C (inside)
s_{sys} – Status System
<CR><LF> – End of answer

Temperature sensor **indoor** in °C
 Output e.g. +21.06 acc. 21.06 °C
 At heated sensors the heating test has to be successful in order to assure that the temperature sensor will be initialised. If not, 0.00 will be shown.

The returned value of “s_{sys}” is a decimal representation of a binary number. In binary representation the positions correspond to the following status messages. (* see also chapter. 8.3)

Bit position	Status message
0	1 = Error due to exceeding of the heating temperature by 10 °C
1	1 = Error heating
2	1 = Error interior temperature sensor
3	1 = Error funnel temperature sensor

Example: 15 °C ambient temperature, but heating is ON and defect temperature sensor

+0.059;+3.545;+7.701;+1;+15;+5<CR><LF>

8.2.4 Modbus protocol

The LAMBRECHT meteo Modbus sensors and the met[LOG] follow the specification of the Modbus organization: “MODBUS APPLICATION PROTOCOL SPECIFICATION V1.1b3” (see www.modbus.org).

8.2.4.1 Data encoding

MODBUS uses the „big-endian“ format for addresses and data. This means that if a value is transmitted with a number format that is larger than a single byte, the „most significant byte“ is sent first. For values that go beyond one register (e.g. 32 bit) this is not clearly specified for the Modbus. In these cases (32 bit or 64 bit) the LAMBRECHT Modbus sensors follow the big-endian number format.

Example Big-Endian (1 register value):

16 - bit value
 0x1234 is transmitted in the sequence: 0x12 0x34.

Example Big-Endian (2 register value):

32 - bit value
 0x12345678 is transmitted in the sequence: 0x12 0x34 0x56 0x78.

To obtain the real measuring value, divide the received register value by the divisor.
 Values of -9999 (16 bit value) or -9999999 (32 bit value) indicate an internal sensor error.

8.2.4.2 Device address

The addresses 1...247 are permitted for Modbus.

8.2.4.3 Standard configuration - Default

Baud rate: 19200 Baud
 Address: Each sensor type (or family) has its own default address.

DEFAULT ADDRESSES OF THE LAMBRECHT SENSORS:

Address	Sensor
1	Wind speed
2	Wind direction
3	Precipitation rain[e]
4	THP
5	EOLOS IND; u[sonic]WS6
6	com[b]
7	PREOS
8	ARCO
9	u[sonic]
10	Pyranometer 2nd Class
11	Secondary standard Pyranometer
12	PT100 to Modbus converter (temperature)
13	u[sonic]WS7

Byte frame acc. to MODBUS standard for RTU mode: 8E1 (1 start bit, 8 data bits, 1 parity bit (even parity), 1 stop bit)

8.2.4.4 Modbus command set

The LAMBRECHT Modbus sensors support the following commands:

- “Read Holding Register” command: 0x03 (descriptive sensor data registers)
- “Read Input Register” command: 0x04 (measured values registers, every measured value is to be requested individually)
- “Write Multiple Register” command: 0x10 (write to configuration registers)

8.2.4.5 Measured value and parameter register LAMBRECHT sensors

The register range 30001 to 35000 of the LAMBRECHT sensors is intended for measured values.

The following measured values are provided by the rain[e] precipitation sensors.

Register	Parameter name	Unit	Divisor	Quantity of registers	Access type	
31001	Precipitation amount total (standard resolution)	mm	10	1	Read only	INT
31101	Precipitation amount total (high resolution)	mm	1000	2	Read only	LONG
31103	Precipitation amount since last retrieval (high resolution)	mm	1000	2	Read only	LONG
31201	Precipitation intensity 1-minute sliding	mm/min	1000	1	Read only	INT
34901	Status of sensor	-	1	1	Read only	INT
34921	Status of heater	-	1	1	Read only	INT
34922	Internal temperature	°C	10	1	Read only	INT
34931	Total heating power in %	%	1	1	Read only	INT



The registers addresses 30001 to 35000 apply to all LAMBRECHT meteo Modbus sensors, but are only available or valid if the respective sensor supports the corresponding values (e.g. a pure wind sensor does not provide any air humidity).

The LAMBRECHT sensors give 0xD8F1=-9999(16 bit) or 0xFF676981=-9999999 (32 bit) as error code or invalid value.

Example: Precipitation amount total (standard resolution)

03	04	79	19	00	01	F8	B3	03	04	02	00	01	01	30
----	----	----	----	----	----	----	----	----	----	----	----	----	----	----

LEN 6	Transmission Query =>	Source Master	Dest Slave 3	Function Read Input Register (4)	Func Desk Address=31001, Quantity of Register=1	Checksum OK:B3F8
LEN 5	Transmission Response <=	Source Slave 3	Dest Master	Function Read Input Register (4)	Func Desk Byte count=2	Data 00 01 Checksum OK:3001

Example: Precipitation amount total (high resolution)

03	04	79	7D	00	02	F9	6D	03	04	04	00	00	00	91	19	E8
----	----	----	----	----	----	----	----	----	----	----	----	----	----	----	----	----

LEN 6	Transmission Query =>	Source Master	Dest Slave 3	Function Read Input Register (4)	Func Desk Address=31101, Quantity of Register=2	Checksum OK:6DF9
LEN 7	Transmission Response <=	Source Slave 3	Dest Master	Function Read Input Register (4)	Func Desk Byte count=4	Data 00 00 00 91 Checksum OK:E819

8.2.4.5.1 Special case precipitation quantity

Except for the amount of precipitation, all measured values are to be read in as instantaneous values. The amount of precipitation must be read in as a total amount. And the difference to the previous call must be formed for the displayed and the precipitation quantity to be stored.

Note: The value overflow of the precipitation sum must be considered when calculating the difference. The value overflow occurs at 60,000 g of collected liquid. This results in a value overflow at 3,000 mm for sensors with a collecting surface of 200 cm² and a value overflow at 1,500 mm for sensors with a collecting surface of 400 cm².

8.2.4.5.2 Sensor status

The sensor status can be retrieved by using register 34901. The returned numerical value must be interpreted in binary form as follows.

Bit position	Status message
0	1 = error maximum heating temperature threshold exceeded
1	1 = error heating
2	1 = error temperature sensor interior
3	1 = error temperature sensor at the funnel
4	1 = error initialization RTC
5	1 = error external temperature sensor (only rain[e]H3)
6	1 = poor quality of supply voltage (only rain[e]H3)

8.2.4.6 Descriptive sensor parameter registers (Holding register)

Register	Parameter name	Quantity of registers	Remark	Access type
40050	Device identification number (15 characters)	8 (2 characters in each register)	The returned data are in form of a 16 byte null terminated string	Read only
40100	Serial number (11 characters)	6 (2 characters in each register)	The returned data are in form of a 12 byte null terminated string	Read only
40150	Firmware version (up to 25 characters)	13 (2 characters in each register)	The returned data are in form of a 26 byte null terminated string	Read only

Example: Retrieve the device identification number (the identification number shown in the example is sensor-dependent; it is only used here for demonstration purposes)

															ASCII	
05	03	9C	72	00	08	CB	C3	05	03	10	30	30	2E	31	36	□□□□□□□□□□□□□□
34	38	30	2E	30	30	30	31	33	30	00	37	CA				00.16480.000130.□□

LEN 6	Transmission Query =>	Source Master	Dest Slave 5	Function Read Holding Register (3)	Func Desk Address=40050, Quantity of Register=8	Checksum OK:C3CB	
LEN 19	Transmission Response <=	Source Slave 5	Dest Master	Function Read Holding Register (3)	Func Desk Byte count=16	Data 30 30 2E 31 36 34 38 30 2E 30 30 30 31 33 30 00	Checksum OK:CA37

8.2.4.7 Sensor parameters / Configuration parameters

Register	Parameter name	Allowed values	Quantity of registers	Access type
40001	Modbus device address		1	Write only
40200	Baud rate	96 = 9600 192 = 19200	1	Write only
40201	Parity	1 = even 0 = none	1	Write only

The device must be restarted after each change of a setting!

Example: Change the RTU address from 3 to 1

03	10	9C	41	00	01	02	00	01	2D	E8	03	10	9C	41	00	01	7E	6F
----	----	----	----	----	----	----	----	----	----	----	----	----	----	----	----	----	----	----

LEN 9	Transmission Query =>	Source Master	Dest Slave 3	Function Write Multiple Register (16)	Func Desk Address=40001, Quantity=1	Byte count 2	Register values 00 01	Checksum OK:E82D
LEN 6	Transmission Response <=	Source Slave 3	Dest Master	Function Write Multiple Register (16)	Func Desk Address=40001, Quantity=1	Checksum OK:6F7E		

8.2.4.8 Autoconfiguration

All LAMBRECHT meteo Modbus sensors offer the experienced user the possibility to implement an auto-configuration in his Modbus master based on additional information stored in the sensor. The necessary information can be found in the document “General Manual for LAMBRECHT meteo Modbus Sensors”.

8.3 Total precipitation

For the measurement of the precipitation amount from data set to data set via the serial protocols (e.g. SDI 12, Talker, Modbus) the difference of the total precipitation amount to the previous value must be calculated.

Note: The value overflow of the precipitation total must be taken into account in the calculation of the difference. The value overflow occurs at 60000 g of collected liquid. This results in a value overflow at 3000 mm for sensors with a collecting surface of 200 cm² and a value overflow at 1500 mm for sensors with a collecting surface of 400 cm².

8.4 Pulse output

Each pulse corresponds to a predefined amount of measured precipitation. The rocker factor value range is 0.01...200 mm/pulse. The rocker factor can be set with the rain[e] Commander together with the closing time / pulse width. The duty cycle is 1:1 - so the closing time is as long as the pause time.

If more pulses have to be output than is possible with the set rocker factor and closing time, the excess pulses are queued and output as soon as no more pulses are added.

Assuming now the scenario that e.g. with a closing time of 100 ms (corresponding to a maximum of 300 pulses per minute) and a rocking factor of 0.01 mm/pulse [order changed] precipitation is collected with an intensity of a constant 4 mm/min (corresponding to 400 pulses/min) over the duration of 2 min followed by a sustained precipitation intensity of 1.9 mm/min (corresponding to 190 pulses per minute), then the pulse output will output the maximum 300 pulses in each of the first 2 minutes and 200 pulses will go into the queue. In the third minute, 300 pulses are output again - 190 because of the current precipitation and 110 from the queue. Correspondingly, 280 pulses are output in the fourth minute and 190 pulses are output in all subsequent minutes. In this case, therefore, the pulses in the queue are only processed after the fourth minute.

8.5 Analog output

ABSOLUTE SUM OF PRECIPITATION

In this operating mode the accumulated amount of precipitation is returned as an increasing analog signal corresponding to the amount of precipitation. The output can be configured to return the amount as an increasing current or an increasing voltage. If the maximum value of the selected range, e. g. 20 mA for a range of 4...20 mA is exceeded, a new summation starts, i. e. the analog signal starts again on the lower end of the scale - resulting in a sawtooth diagram. The resolution is defined by the chosen scale maximum corresponding to the maximum of the output signal. The scale maximum as well as the output mode and output signal range can be configured with the rain[e] Commander (see chapter 7).

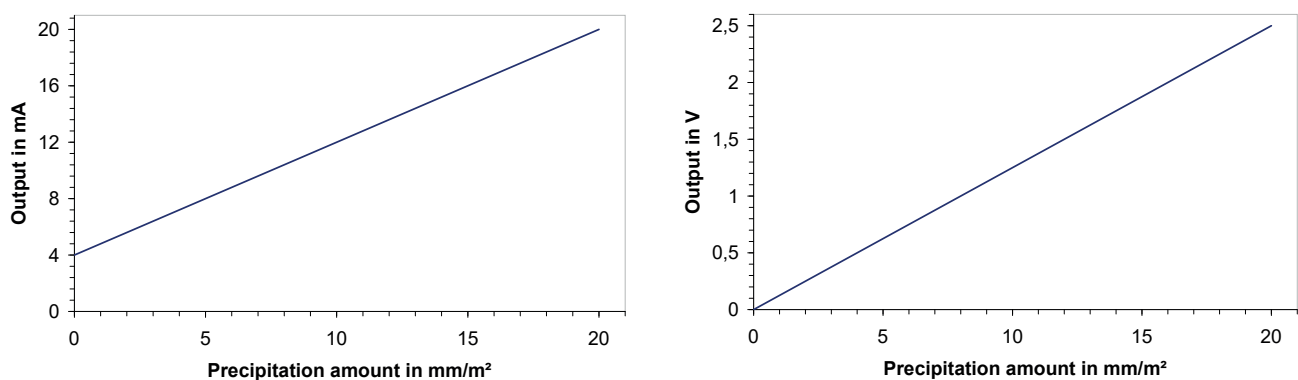

Fig. 26

RESET OF ANALOG OUTPUT SIGNAL

By an external switch at the pins “**IN MULTIPURPOSE**” the analog output can be reset to the lower end (starting value) of the output range. This means that e. g. at the range of 4...20 mA the output will be reset to 4 mA. The summation of precipitation amount starts at zero again.

9 Inspection and troubleshooting

- Visual checks for contamination should be done on a regular basis - depending on the environment and seasonal situation (spider and bird population, pollen, leaf fall). According to chapter 6 of the “VDI Guidelines - Environmental meteorology - Meteorological measurements - Precipitation, VDI 3786 Part 7 (December 2010)” we recommend monthly checks. In areas with high air pollution weekly checks might be necessary to ensure correct measuring results.



Pull the power plug and sensor connector before cleaning the device interior to prevent it from erroneous measurements. Funnel heating and drain heating can be very hot if the heating is operated with the opened housing. There is a risk of being burnt! It is therefore recommended to disconnect the connector of the heating supply during cleaning and maintenance work.

- All water-bearing parts should be cleaned regularly. Rinsing should be sufficient to clean the sensor from most contamination. Dirt clinging to the collecting funnel or outlet pipe has to be removed carefully. Slight pollution of the collecting vessel is not critical. The collecting vessel can be cleaned with water and a mild cleaning agent.

- Make sure the instrument is in a stable and perpendicular position and check the ring, the funnel surface and the sensor for damages.
- Keep the measurement site free from overgrowing vegetation.
- The bird protection has to be removed before the frost period.



Please be careful while cleaning the collecting vessel to prevent it from taking damage. The rain[e] and the collecting vessel must not be cleaned with steel brushes or similar tools or aggressive detergents.

TROUBLESHOOTING

The heating got shut down after installing the device (error string: “error heating” = 1):

- Unplug the power plug of the sensor
- Control the power plug of the heating and the clamp plug of the funnel heating to be plugged in
- Plug in the power plug of the sensor

If this does not fix the problem, there are the following reasons

- Floor heating does not work, is not internally connected
 - Funnel heating does not work
 - Power cable of the heating is too long or defective
- ⇒ Please contact the LAMBRECHT meteo Service.

Error message, when trying to retrieve data from the rain[e] with the rain[e] Commander:

Please reconnect the USB cable and restart the rain[e] Commander.

rain[e] Commander returns “COM port not found” or “rain[e] does not respond!”:

- Check if the rain[e] is correctly connected to the Laptop/Tablet and the correct COM port is selected.
- Restart the rain[e] Commander.

10 Maintenance and repair

In case you should be faced with any specific problems please contact the LAMBRECHT meteo service on:

Tel: +49-(0)551-4958-0
E-mail: support@lambrecht.net

11 Equipment and spare parts

General Accessories

32.15184.060000	Connecting cable with M12 plug (for connection sensor data logger); L = 10 m (8-core)
32.14581.060000	Connecting cable, 10 m, 5 pole (for rain[e]LP)
65.53090.160100	USB cable for sensor configuration
36.15184.000000	rain[e] Commander
00.15180.400000	Stainless steel mast for concrete foundation
00.15180.800050	Stainless steel mast for concrete foundation with base plate
32.15180.022040	Bird defense ring for rain[e]400 and rain[e]314
32.15180.023020	Bird defense ring for: rain[e], rain[e]one Modbus, rain[e]LP
33.15189.049010	Dirt spiral (spare part)
32.15184.080000	Maintenance set (2 calibration balls, cleaning spray, brush, CD with rain[e] Commander, MiniUSB-USB cable, case, calibration manual)

Accessories for rain[e] Modbus versions

32.14567.060010	Connecting cable with M12 plug (sensor) L ≈ 15 m (4-core), A-coded
32.14567.060000	Connecting cable with M12 plug (sensor) L ≈ 12 m (4-core), A-coded

Accessories for heated versions

00.14966.200000	Power supply 150 W · not for rain[e]400H and rain[e]400H
00.14966.500000	Power supply 240 W · for rain[e]400H and rain[e]314H
32.15184.061000	Connecting cable (heating) for mounting at the mast; L ≈ 1 m (4-core)
32.15184.061010	Connecting cable (heating) for mounting at the mast; L ≈ 10 m (4-core), T-coded
32.14622.220000	Holder for power supply unit on the mast

Services

97.15180.000000	User-specific configuration
-----------------	-----------------------------



CONNECTING DIAGRAM FOR CUSTOMIZED CONFIGURATION

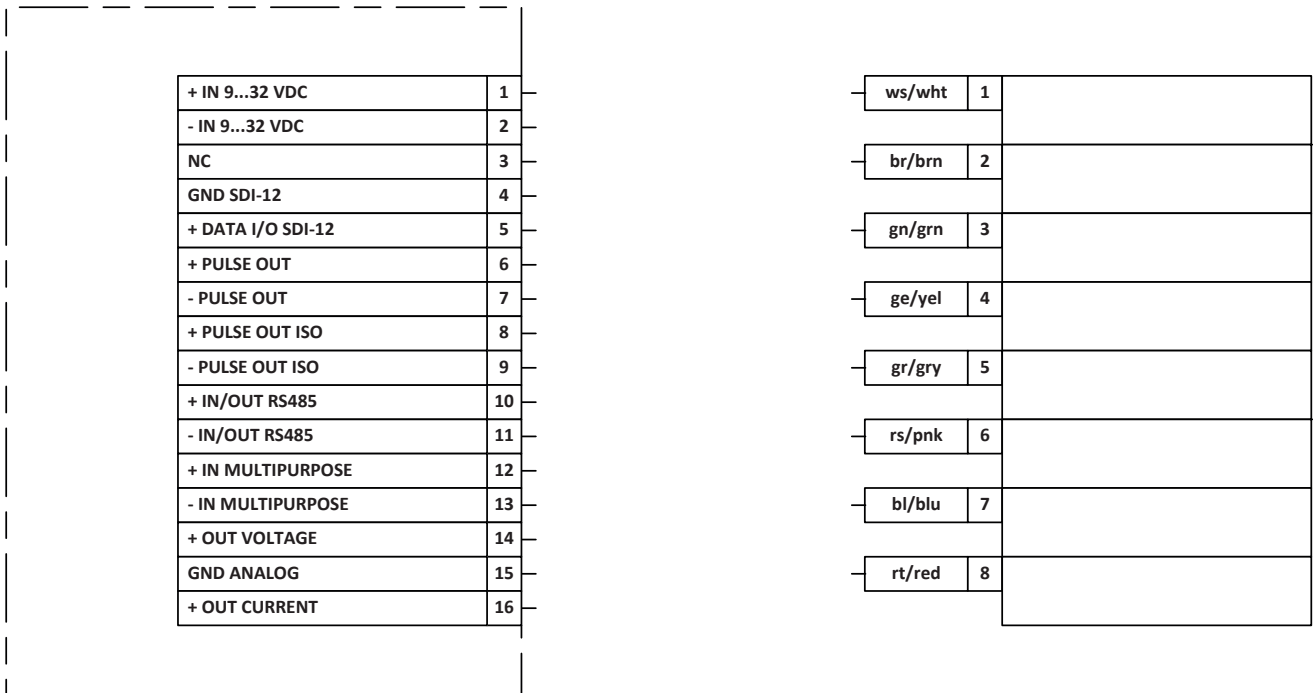

Note: The SDI-12 interface and the RS485 interface cannot be used simultaneously. Furthermore, it is recommended to apply only one of the two interfaces to the cable used at the same time.

Fig. 27

12 Download of updates

On our homepage (<https://www.lambrecht.net>) you will find free firmware and the configuration software “Commander” for your product under “Service” in the “Download Portal” in the section “Free Software Tools & Firmware”. Select the appropriate software for your product and benefit after the download from new functions and product enhancements by LAMBRECHT meteo development.

13 Technical data I

	rain[e] unheated ID 00.15184.000000	rain[e] heated ID 00.15184.400000	rain[e]400 H heated ID 00.15184.404000	rain[e]400 unheated ID 00.15184.004000
Measurable precipitation types:	liquid (solid, mixed – with heated sensor)			
Measurement principle:	weighing with automatic self-emptying			
Operating temperature:	0...+70 °C	-40...+70 °C (no icing or snow drifting)		0...+70 °C
Storage temperature:	-40...+70 °C			
Collecting area:	200 cm ²		400 cm ²	
Measuring range (amount):	without limitation (0.005...∞ mm)		without limitation (0.0025...∞ mm)	
Resolution (amount):	0.001 mm (pulse output: 0.01 mm)			
Accuracy (amount):	0.1 mm or 1 % at < 6 mm/min and 2 % at ≥ 6 mm/min		0.1 mm or 1 % at < 3 mm/min and 2 % at ≥ 3 mm/min	
Measuring range (intensity):	0...20 mm/min resp. 0...1200 mm/h		0...10 mm/min resp. 0...600 mm/h	
Resolution (intensity):	0.001 mm/min resp. 0.001 mm/h			
Accuracy (intensity):	0.1 mm/min resp. 6 mm/h			
Dimensions:	292 mm x 190 mm (h x d), see dimensioned drawing		311 mm x 256 mm (h x d), see dimensioned drawing	
Mountable on:	Ø 60 mm			
Weight:	approx. 2.5 kg		approx. 4 kg	
Standards:	WMO-No. 8; VDI 3786 Bl. 7; EN 61000-2, -4; EN 61000-4-2, -3, -4, -5, -6, -11; NAMUR NE-21			
Protection class load cell:	IP67			
Current consumption:	max. 45 mA at 24 V power supply and analog output; typically 6.5 mA at 24 V power supply and pulse output; typically 12.5 mA at 12 V			
Supply voltage:	9.8...32 V DC			
Heating data:	---	electronically controlled, dual-circuit-heating		---
Target temperature:	---	+2 °C funnel surface temperature		---
Accuracy:	---	±1 °C		---
Heating power:	---	80 W (funnel)	150 W (funnel)	---
		60 W (outlet/collecting vessel)		
Supply voltage:	---	24 V DC / 140 W	24 V DC / 210 W	---

SIGNAL OUTPUTS

- SDI-12 or RS485 (SDI-12 protocol, ASCII protocol, TALKER protocol, and Modbus RTU)
- linearized, bounce-free pulse output signal or status output (configurable, e.g. 'Rain YES/NO' or 'Heating ON/OFF')
 - Pulse 1 (galvanically isolated, open collector): Max. 24 V DC / max. 0.05 A / max. 0.5 W
 - Pulse 2 (open collector): Max. 24 V DC / max. 0.1 A / max. 0.5 W
- Analog output
 - 0/4...20 mA – max. load 500 Ω at 24 V DC or 0...2.5/5 V
with reset output function



14 Technical data II

	rain[e]314 unheated ID 00.15184.003000	rain[e]314 heated ID 00.15184.403000
Measurable precipitation types:	liquid (solid, mixed – with heated sensor)	
Measurement principle:	weighing with automatic self-emptying	
Operating temperature:	0...+70 °C	-40...+70 °C (no icing or snow drifting)
Storage temperature:	-40...+70 °C	
Collecting area:	314 cm ²	
Measuring range (amount):	without limitation (0.0032...∞ mm)	
Resolution (amount):	0.001 mm (pulse output: 0.01 mm)	
Accuracy (amount):	0.1 mm or 1 % at < 3.82 mm/min and 2 % at ≥ 3.82 mm/min	
Measuring range (intensity):	0...12 mm/min resp. 0...720 mm/h	
Resolution (intensity):	0.001 mm/min resp. 0.001 mm/h	
Accuracy (intensity):	0.1 mm/min resp. 6 mm/h	
Dimensions:	311 mm x 256 mm (h x d), see dimensioned drawing	
Mountable on:	Ø 60 mm	
Weight:	approx. 4 kg	
Standards:	WMO-No. 8; VDI 3786 Bl. 7; EN 61000-2, -4; EN 61000-4-2, -3, -4, -5, -6, -11; NAMUR NE-21	
Protection class load cell:	IP67	
Current consumption:	max. 45 mA at 24 V power supply and analog output; typically 6.5 mA at 24 V power supply and pulse output; typically 12.5 mA at 12 V	
Supply voltage:	9.8...32 V DC	
Heating data:	---	electronically controlled, dual-circuit-heating
Target temperature:	---	+2 °C funnel surface temperature
Accuracy:	---	±1 °C
Heating power:	---	150 W (funnel) 60 W (outlet/ collecting vessel)
Supply voltage:	---	24 V DC / 210 W

SIGNAL OUTPUTS

- SDI-12 or RS485 (SDI-12 protocol, ASCII protocol, TALKER protocol, and Modbus RTU)
- linearized, bounce-free pulse output signal **or** status output (configurable, e.g. 'Rain YES/NO' or 'Heating ON/OFF')
 - Pulse 1 (galvanically isolated, open collector): Max. 24 V DC / max. 0.05 A / max. 0.5 W
 - Pulse 2 (open collector): Max. 24 V DC / max. 0.1 A / max. 0.5 W
- Analog output
 - 0/4...20 mA – max. load 500 Ω at 24 V DC or 0...2.5/5 V
with reset output function

15 Technical data III

	rrain[e]one Modbus unheated ID 00.15184.000101	rain[e]one Modbus heated ID 00.15184.401001
Measurable precipitation types:	liquid (solid, mixed – with heated sensor)	
Measurement principle:	weighing with automatic self-emptying	
Operating temperature:	0...+70 °C	-40...+70 °C (no icing or snow drifting)
Storage temperature:	-40...+70 °C	
Collecting area:	200 cm ²	
Measuring range (amount):	without limitation (0.0025...∞ mm)	
Resolution (amount):	0.001 mm (pulse output: 0.01 mm)	
Accuracy (amount):	0.1 mm oder 2 %	
Measuring range (intensity):	0...10 mm/min resp. 0...600 mm/h	
Resolution (intensity):	0.001 mm/min resp. 0.001 mm/h	
Accuracy (intensity):	0.1 mm/min resp. 6 mm/h	
Dimensions:	292 mm x 190 mm (h x d), see dimensioned drawing	
Mountable on:	Ø 60 mm	
Weight:	approx. 2.5 kg	
Standards:	WMO-No. 8; VDI 3786 Bl. 7; EN 61000-2, -4; EN 61000-4-2, -3, -4, -5, -6, -11; NAMUR NE-21	
Protection class load cell:	IP67	
Current consumption:	max. 45 mA at 24 V power supply and analog output; typically 6.5 mA at 24 V power supply and pulse output; typically 12.5 mA at 12 V	
Supply voltage:	9.8...32 V DC	
Heating data:	---	electronically controlled, dual-circuit-heating
Target temperature:	---	+2 °C funnel surface temperature
Accuracy:	---	±1 °C
Heating power:	---	80 W (funnel) 60 W (outlet/ collecting vessel)
Supply voltage:	---	24 V DC / 140 W

SIGNAL OUTPUTS

- RS485 (Modbus RTU)
- linearized, bounce-free pulse output signal **or** status output (configurable, e.g. 'Rain YES/NO' or 'Heating ON/OFF')
 - Pulse 1 (galvanically isolated, open collector): Max. 24 V DC / max. 0.05 A / max. 0.5 W **or**
 - Pulse 2 (open collector): Max. 24 V DC / max. 0.1 A / max. 0.5 W



16 Technical data IV

rain[e] LP ID 00.15184.010000	
Measurable precipitation types:	liquid
Measurement principle:	weighing with automatic self-emptying
Operating temperature:	0...+70 °C
Storage temperature:	-40...+70 °C
Collecting area:	200 cm ²
Measuring range (amount):	without limitation (0.005...∞ mm)
Resolution (amount):	0.001 mm (pulse output: 0.01 mm)
Accuracy (amount):	0,1 mm oder 1 % at < 6 mm/min and 2 % at ≥ 6 mm/min
Measuring range (intensity):	0...20 mm/min resp. 0...1200 mm/h
Resolution (intensity):	0.001 mm/min resp. 0.001 mm/h
Accuracy (intensity):	0.1 mm/min resp. 6 mm/h
Dimensions:	292 mm x 190 mm (h x d), see dimensioned drawing
Mountable on:	Ø 60 mm
Weight:	approx. 2.5 kg
Standards:	WMO-No. 8; VDI 3786 Bl. 7; EN 61000-2, -4; EN 61000-4-2, -3, -4, -5, -6, -11; NAMUR NE-21
Protection class load cell:	IP67
Current consumption:	typically 6.9 mA at 12 V power supply
Supply voltage:	9.8...12 VDC
Heating data:	---
Target temperature:	---
Accuracy:	---
Heating power:	---
Supply voltage:	---

SIGNAL OUTPUT

- SDI-12
- linearized, bounce-free pulse output signal **or** status output (configurable, e.g. 'Rain YES/NO' or 'Heating ON/OFF')
 - Pulse 1 (galvanically isolated, open collector): Max. 24 V DC / max. 0.05 A / max. 0.5 W **or**
 - Pulse 2 (open collector): Max. 24 V DC / max. 0.1 A / max. 0.5 W