



USER MANUAL

REED

Wind Sensor



Content

Wind speed sensor REED	3
Benefits at a glance	3
Warranty	3
Initial operation	4
Selecting the place of installation	4
Installation	4
Mast or pipe mounting	4
Mounting on traverse with bore hole	5
Mounting on third-party mounting devices	5
Electrical connection	5
Maintenance	6
Disposal	6
Wiring diagram	7
Dimensional drawing	8
Technical data	9

Wind speed sensor REED

- Exceptionally economical investment because of excellent price-performance ratio
- Non-contact measuring principle
- Proven aluminium housings for safe and long-term use
- Fail-safe three-armed cup rotor for highest capacity
- Aerodynamical design for precise and safe measurements

Benefits at a glance

- Compact, high-performance wind sensor REED with frequency output for determination of wind speed
- Integrated heating allows operation of the sensor even in winter
- Double precision ball bearing of the measuring element on the rotation axis for low friction and thus low starting values, high reliability and longevity
- Easy installation by screw-in-fastening for mast, flange or bore for a high degree of flexibility
- Very low needs of maintenance

Warranty

Please note the loss of warranty and non-liability by unauthorized manipulation of the system. You need a written permission of the LAMBRECHT meteo GmbH for changes of system components. These activities must be operated by a qualified technician.

The warranty does not cover:

1. Mechanical damages caused by external impacts (e. g. icefall, rockfall, vandalism).
2. Impacts or damages caused by over-voltages or electromagnetic fields which are beyond the standards and specifications in the technical data.
3. Damages caused by improper handling, e. g. by wrong tools, incorrect installation, incorrect electrical installation (false polarity) etc.
4. Damages which are caused by using the device beyond the specified operation conditions.

Initial operation

Wind can be represented by a vector quantity. For a complete description of the wind it is necessary to specify its speed and direction. The two components are subject to spatial and temporal variations; thus, strictly speaking, they are valid only for the site where the measuring instrument is put up. We therefore recommend to select the place of installation very carefully.

Selecting the place of installation

Generally, wind measuring instruments should not measure the specific wind conditions of a limited area, but indicate the typical wind conditions of a wider area. The values measured at different places must be comparable. Thus, when installing the sensor you should make sure the place of installation is not under the lee of great obstacles. The distance between the obstacles and the sensor should be 10 times the height of the obstacles (this corresponds to the definition of an undisturbed terrain).

If an undisturbed terrain of this kind does not exist the sensor must be put up at a height of at least 5 m above the obstacle height. If the sensor must be installed on a roof top the place of installation must be in the middle of the roof to avoid predominant wind directions. If you want to measure both wind direction and wind speed, install the sensors at the same measuring point, if possible, and make sure to avoid any mutual influence of the sensors.

Installation



Because the installation takes place in a dangerous height, the assembly personal must follow the rules for prevention of accidents.

Mast or pipe mounting



Make sure that the sensor should remain easily accessible for possible maintenance work. For access to the sensors use a ladder of the appropriate length or a telescope working platform of the appropriate height, if applicable.



Ladders or other climbing aids must be in perfect order and guarantee a secure hold! Follow the rules for prevention of accidents.

Masts or tubes (grounded) suitable for mounting have an outer diameter of \varnothing 48-50 mm. A mast adapter (see accessories) is necessary.



MOUNTING OF THE WIND SENSOR WITH THE MAST ADAPTER (ID 32.14567.006000)

1. Remove both thread nuts from the sensor.
2. Insert the sensor into the bore (\varnothing 30 mm) of the adapter.
3. Fasten the sensor with the flat side of a detached nut from the lower side. Tighten with a suitable tool (wrench size 36), until a twisting safety of the sensor is given.
4. And finally we recommend to lock the second nut with its plane side ahead against the first nut (see drawing).
5. Install the cable for supply of the sensor electronic and transmission of the sensor signal inside the mast.
6. The sensor is placed on the mast (tube) with the adapter. Afterwards fasten the locking screw in the mast adapter to give the sensor a fixed and torsion-free fit.
7. Proceed analogously when mounting the sensor on a tube traverse.

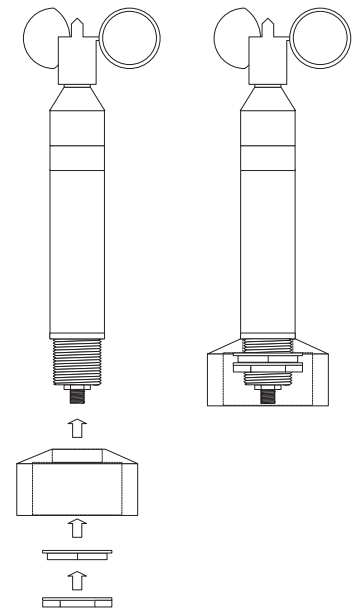

Mounting on traverse with bore hole

The traverse (Id-No. 32.14627.010000) has a bracket with a \varnothing 30 mm hole at each end.

1. Remove the lower nut from the sensor.
2. Put a sensor sidewise into the bore.
3. Fasten the sensor with the flat side of the detached nut from the lower side. Tighten with a suitable tool (wrench size 36), until a twisting safety of the sensor is given.

Mounting on third-party mounting devices

The general requirements for a sensor mounting device include a flat material with a maximum thickness of 10 mm into which a 30 mm hole is drilled.

Mounting is to be made in the following steps:

1. Remove the lower thread nut from the sensor.
2. The sensor is inserted into the hole and fastened from the opposite side with the nut removed under 1.

Electrical connection

Wind sensors REED are connected to a data measuring system via the open cable end. Normally, the sensors have a cable connector to the connection cable. The connecting cable is suitably led along the mast between the data evaluation device (indicating instrument or data acquisition system) and the sensor. The cable must be fastened using appropriate cable ties (their length depends on the mast diameter).



Lead the cable from the mast over a generously dimensioned bend to the housing base of the sensor to allow easy disassembly and a water trap.

Alternatively the connection cable can be laid also completely in the pipes of a mast if the mast is accordingly prepared.

Please make sure the cable is protected from humidity on the side of the data processing system. Generally, Pg sockets that use a rubber joint to prevent humidity from penetrating into the terminal box of the data processing system provide sufficient protection.



Example illustration:
Cable routing through an EMC-compliant Pg socket



To reduce the risk of inductive interference the sensor must be properly grounded (screening on both sides).

Maintenance

The sensor design permits long periods of maintenance-free operation. Regular visual inspection and sensor calibration every 2 years is recommended. With problems, which cannot be solved by you, please do not hesitate to contact our Lambrecht meteo service under:

Tel: +49 (0)551-4958-0

E-Mail: support-lambrecht@aem.eco

Disposal

LAMBRECHT meteo GmbH is listed and registered at the Stiftung Elektro-Altgeräte Register ear under:

WEEE-Reg.-Nr. DE 45445814

In the category of monitoring and control instruments, device type: "Monitoring and control instruments for exclusively commercial use".

Within the EU



The device has to be disposed according to the European Directives 2002/96/EC and 2003/108/EC (Waste Electrical and Electronic Equipment). Do not dispose the old device in the household waste! For an environmentally friendly recycling and disposal of your old device, contact a certified disposal company for electronic waste.

Outside the EU

Please follow the regulations in your country regarding the appropriate disposal of waste electronic equipment.



Wiring diagram

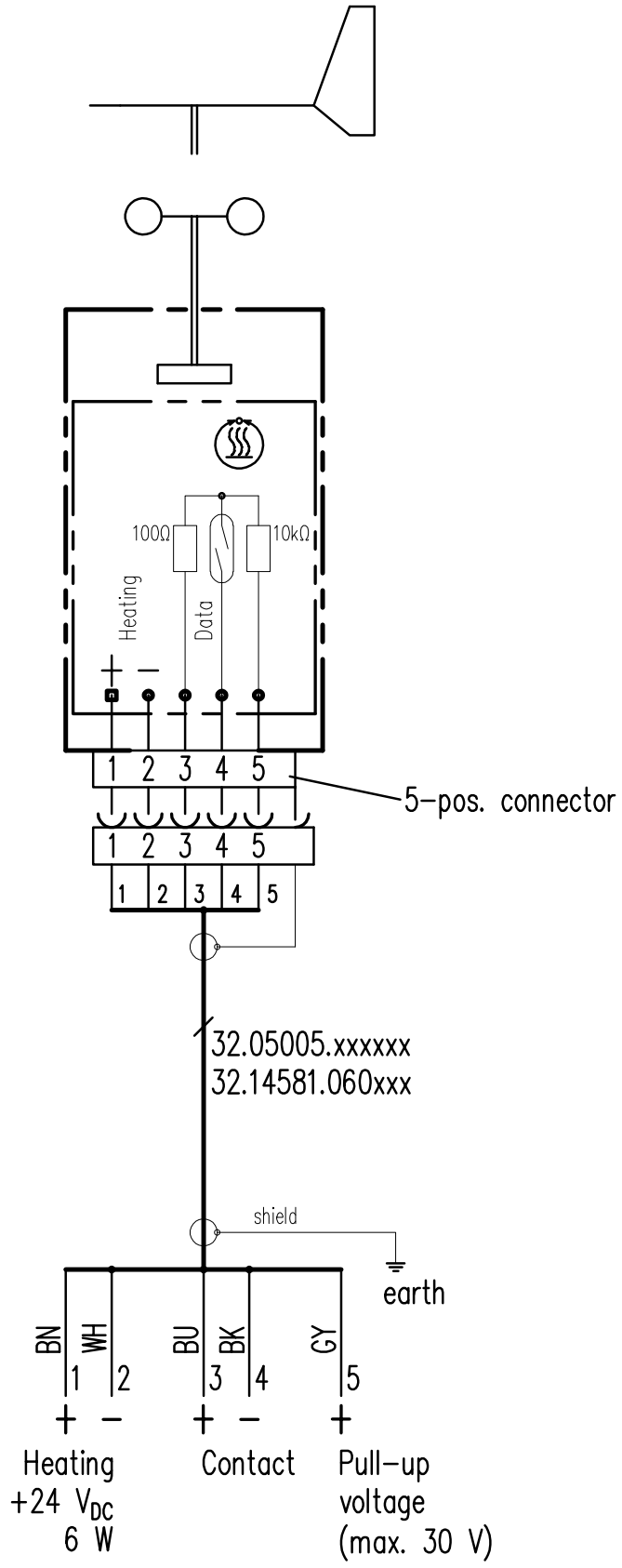

Dimensional drawing

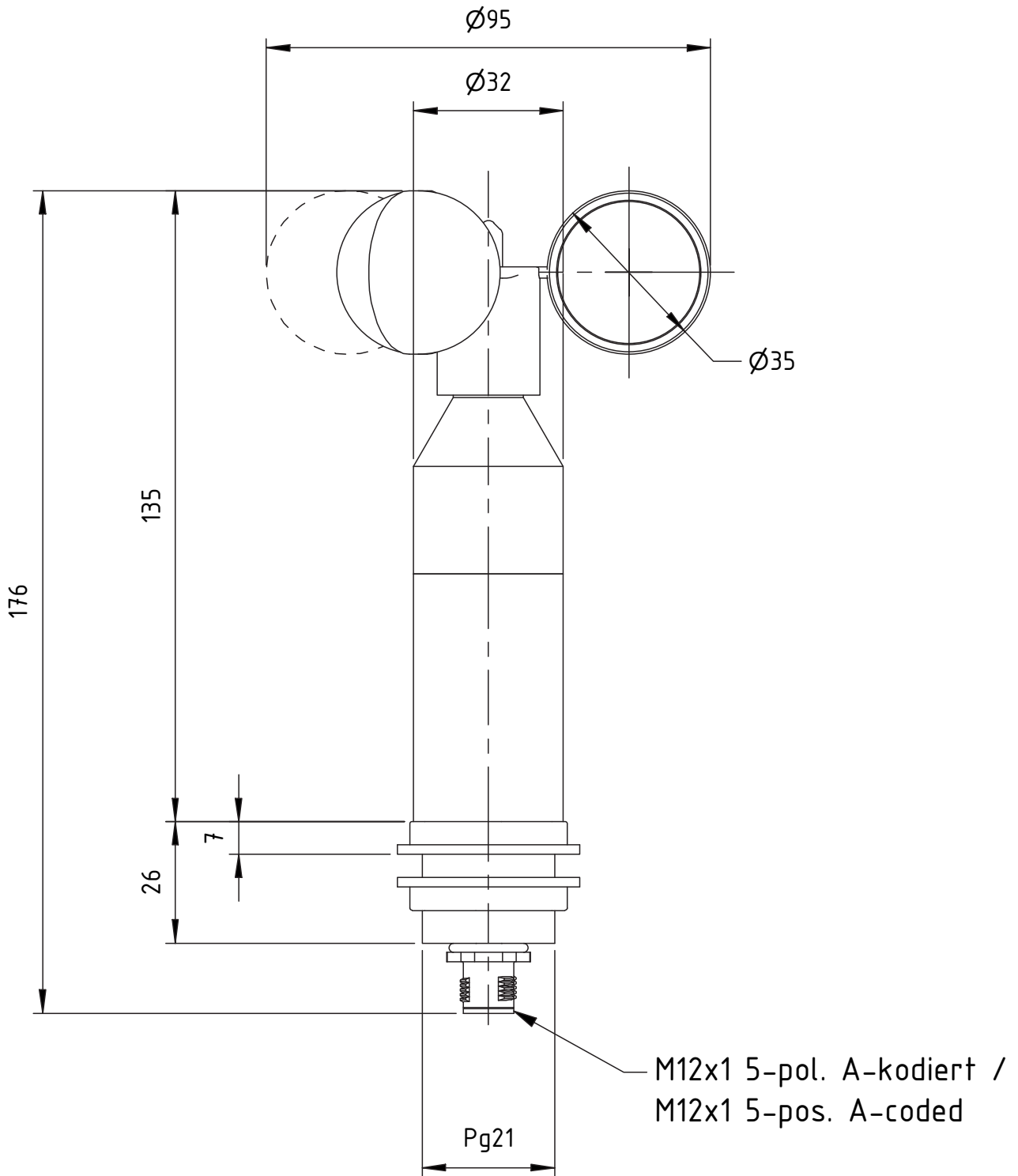

Technical data

REED WIND SENSOR 14595	
ID	00.14595.211070 Wind speed sensor REED, unheated 00.14595.201070 Wind speed sensor REED, heated
Measuring element	3-armed cup rotor; break-proof plastic
Measuring principle	reed switch; non-contact
Measuring range	0.7...50 m/s
Accuracy	2% FS
Resolution	0.26 m/s
Starting value	0.7 m/s
Output	frequency · 0...192 Hz = 0...50 m/s
Range of application	temperature: -40...+70 °C heated *) wind speed: up to 60 m/s relative humidity: 0...100 % r. h. (non condensing)
Survival wind speed	60 m/s
Supply voltage	6 W heating; nominal 24 VDC *)
Housing	seawater resistant aluminum; IP 65; for mounting holes Ø 30 mm with max. 10 mm material thickness
Dimensions	see dimensional drawing
Weight	approx. 0.35 kg
Normen/ Standards	VDI 3786, sheet 2; WMO No. 8

Accessories (please order separately)	
ID 32.14581.060000	10 m sensor connection cable with plug connector M12, 5-wire
ID 32.14627.010000	Traverse for wind sensors
ID 32.14567.006000	Adapter for mast mounting

*) The heating in the sensor head also allows operation in winter, but cannot prevent the sensor from freezing under all climatic conditions.

Traverse ID 32.14627.010000



Sonderzubehör / extras: No. 32.14567.006000
Adapter für Mastbefestigung / adapter for mast mounting

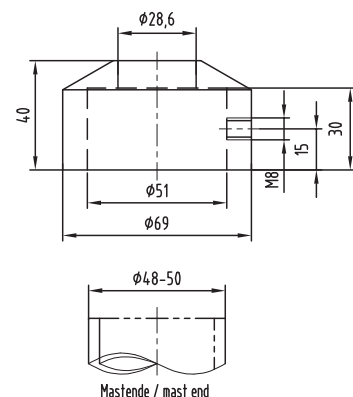

Copyright © 2024 LAMBRECHT meteo GmbH. All rights reserved.
Information in this document subject to change without notice.

REED_b-de.indd 51.24
Photo copyright: © philipus - Adobe stock

LAMBRECHT meteo GmbH
Friedländer Weg 65
37085 Göttingen
Germany

Tel +49-(0)551-4958-0
Fax +49-(0)551-4958-312
E-Mail info-lambrecht@aem.eco
Internet www.lambrecht.net

