



USER MANUAL

ARCO

Wind Sensors

ARCO-SERIAL and ARCO-NAV



Content

1	Warranty	3
2	Disposal	3
3	Introduction	4
4	Start-up	4
4.1	Installation conditions	4
4.1.1	General	4
4.1.2	Ships	5
4.2	Tools and installation material	5
4.3	Unpacking the sensor	5
4.4	Incoming inspection	5
4.5	Power supply	6
4.6	Mounting the cup rotor and wind vane	6
4.7	Installation work (brief description)	6
4.8	Mounting the sensor	7
4.8.1	Adjusting the wind vane	7
4.8.2	Power supply and signal cable	7
4.8.3	Safety regulations	8
5	Maintenance	8
5.1	Regular maintenance and calibrations	8
5.2	Visual inspections and cleaning work	9
6	Transports	9
7	Data protocols	9
8	Dimensional drawings ARCO-SERIAL and ARCO-NAV	10
9	Electrical connections ARCO-SERIAL and ARCO-NAV	11
10	Technical data	12

ARCO-SERIAL and ARCO-NAV

COMPACT AND EXTREMELY ROBUST WIND/SHIP SENSOR

ARCO-SERIAL for measuring wind direction and wind speed

ARCO-NAV for measuring wind direction and wind speed, especially on ships

1 Warranty

Please note the loss of warranty and non-liability by unauthorized manipulation of the system. You need a written permission of the LAMBRECHT meteo GmbH for changes of system components. These activities must be operated by a qualified technician.

The warranty does not cover:

1. Mechanical damages caused by external impacts (e. g. icefall, rockfall, vandalism).
2. Impacts or damages caused by over-voltages or electromagnetic fields which are beyond the standards and specifications in the technical data.
3. Damages caused by improper handling, e. g. by wrong tools, incorrect installation, incorrect electrical installation (false polarity) etc.
4. Damages which are caused by using the device beyond the specified operation conditions.

2 Disposal

LAMBRECHT meteo GmbH is listed and registered at the Stiftung Elektro-Altgeräte Register ear under:

WEEE-Reg.-Nr. DE 45445814

In the category of monitoring and control instruments, device type: "Monitoring and control instruments for exclusively commercial use".

Within the EU



The device has to be disposed according to the European Directives 2002/96/EC and 2003/108/EC (Waste Electrical and Electronic Equipment). Do not dispose the old device in the household waste! For an environmentally friendly recycling and disposal of your old device, contact a certified disposal company for electronic waste.

Outside the EU

Please follow the regulations in your country regarding the appropriate disposal of waste electronic equipment.

3 Introduction

The sensors of the ARCO family are very robust, compact, and extremely reliable. When developing these sensors particular consideration has been given to the fulfillment of meteorological requirements. The system acquires the horizontal air flow and processes the measuring data to the meteorological parameters wind speed and wind direction. The sensors and further system components are mounted in a splash water resistant and dustproof metal housing. The measuring data are automatically transmitted via serial interface RS 485 in talker mode, when the power supply is switched on.

Due to their shock and vibration proof construction the sensors ARCO-SERIAL and ARCO-NAV are particularly qualified for use under severe environmental conditions. The housing and the measuring elements are made of seawater resistant aluminium alloys. The housing, the cup rotor, and the wind vane are anodized; the housing of the ARCO-NAV is lacquered white (RAL 9003). An electronically controlled sensor heating device allows for operation of the sensor over the wide range of -30 to $+70$ °C.

4 Start-up

Wind can be represented by a vector quantity. For a complete description of the wind it is necessary to specify its speed and direction. The two components are subject to spatial and temporal variations; thus, strictly speaking, the values are only valid for the site where the measuring instrument is installed. We therefore recommend selecting the place of installation very carefully.

4.1 Installation conditions

4.1.1 General

For professional wind measurements the location and height of the wind sensor are important for accurate, correct results and representative wind conditions. Ideally, the sensor should be installed 10 m above the ground on a mast. There should also be nothing affecting wind flow within a radius of 150 m around the sensor. This may be buildings, trees, tall towers, lifting cranes, moving vehicles, aircrafts, helicopters or other obstructions. In the case of mobile measurements on vehicles often the above mentioned conditions are not practicable. Then you have to find compromises.

Generally, wind measuring instruments should not measure the specific wind conditions of a limited area, but indicate the typical wind conditions of a wider area. The values measured at different places must be comparable. Thus, when installing the sensor you should make sure the place of installation is not under the lee of great obstacles. The distance between the obstacles and the sensor should be 10 times the height of the obstacles (this corresponds to the definition of an undisturbed terrain). If an undisturbed terrain of this kind does not exist, the sensor must be put up at a height of at least 5 m above the obstacle height.

If the sensor must be installed on a roof top, the place of installation must be in the middle of the roof to avoid predominant wind directions. If you want to measure both wind direction and wind speed, if possible, the sensors should be mounted at the same measuring point, with any mutual interference of the sensors being avoided. The wind sensors ARCO-SERIAL and ARCO-NAV easily meet this requirement.



The sensor must not be installed on to, or close to transmitting plants or antennas. A minimum distance of 2 m is to be kept for interference-free signal transfer.

4.1.2 Ships

For operation on ships you should select a mounting place with little interference from obstacles such as masts, antennas, and chimneys. In most cases the wind sensor will be mounted on the ship's highest mast.



For wind measurements on board of ships, the location and height of the wind sensor are important for representative and accurate measuring results. The sensors should be ideally located on the top of the mast, without any influence from obstacles. If this is not possible, the sensors should be installed on a mast traverse of at least 1.5 m length, on the port side of the ship.

4.2 Tools and installation material

There are no special tools or materials required for installation or maintenance. All work can be carried out with standard tools available in a regular workshop.

4.3 Unpacking the sensor

The sensor is packed in a separate box, carefully protected against mechanical influences, in order to avoid damage during transport. When securely installed, the sensor can withstand shock and vibration, which normally occurs on ships. Please verify that the following parts and documents are enclosed:

- Wind sensor ARCO
 - User manual
- Accessories: (depending on order size, packed separately)
Connection cable with cable plug and cable core ends

4.4 Incoming inspection

Please thoroughly check the delivery with regard to completeness and eventual transport damages. In case of eventual claims please contact us in writing immediately.

4.5 Power supply

The wind sensor requires at the input connector a 24 volt nominal DC power source for operation. The sensor heating has to be supplied with 24 volt DC and has a power consumption of 2.9 W.

4.6 Mounting the cup rotor and wind vane

The drill holes on the cup rotor are arranged in such a way that it can only be mounted in a specific, unambiguous position. All screws have to be used and the cup rotor or the wind vane have to be fixed with them. This ensures the correct direction of rotation. The required Allen key is included in the scope of delivery.

The wind vane can only be mounted in a specific position. Use all two screws to attach the wind vane to the sensor head. This is the only way to ensure a correct measurement of the wind direction.

MOUNTING THE CUP ROTOR

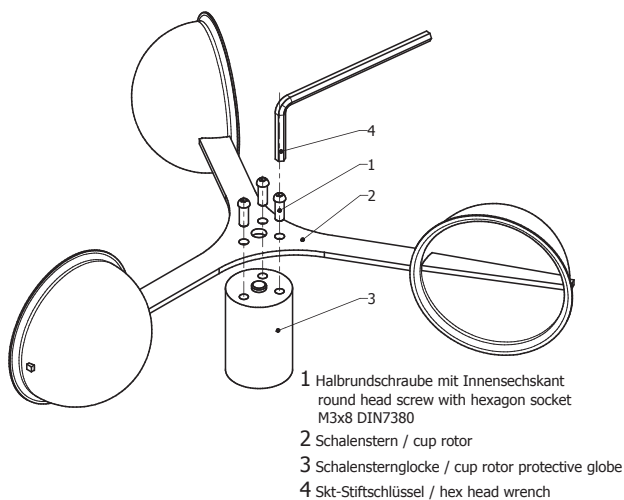

MOUNTING THE WIND VANE

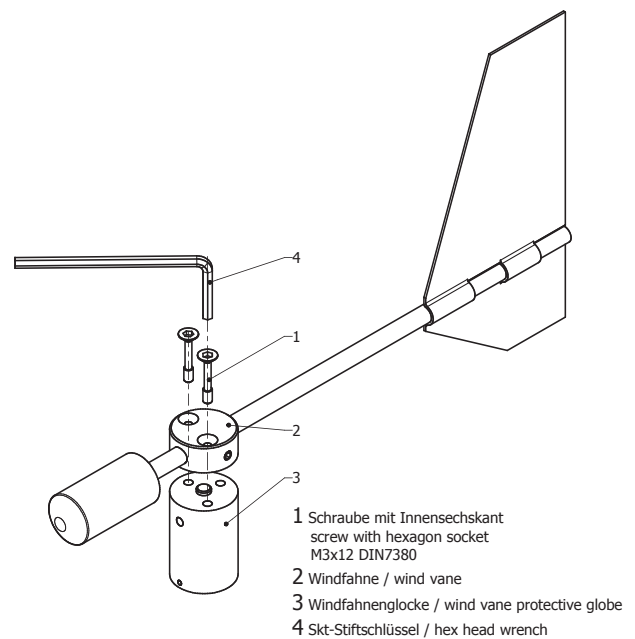

4.7 Installation work (brief description)

The installation of the sensor involves 3 steps:

1. Mounting the cable on the sensor and if necessary drawing the cable through the mast.
2. Mounting the sensor on the mast, but before tightening the screws you must align the sensor to the north.
3. Attaching the cable to the power supply and the signal acquisition system.

4.8 Mounting the sensor

The wind sensor can be installed on a standard pipe with an outer diameter of 50 mm and an inner diameter of at least 40 mm. Before attaching the unit with the two 8 mm socket screws, the cable must be connected, by drawing it through the pipe and the sensor aligned to the north or in the forward driving direction. For this purpose the housing is marked accordingly (see drawing). Adjust the sensor to the north before tightening the screws.



Please make sure that the sensor is firmly attached to the mast!

4.8.1 Adjusting the wind vane

For wind direction measurements the north mark on the sensor must be aligned with the geographical north direction. To adjust the wind sensor in a firm and correct manner into the north direction this item is equipped with an integrated mounting aid. Inside the inner bottom of the sensor a small bolt pointing to the north is integrated to be set into a corresponding slot of the mounting pipe (if available). Thus the sensor is safely attached. If needed you can screw or unscrew the pin by means of an allen key. You have to turn the marking on the wind vane so that it is exactly over the marking on the sensor shaft. Fix the position of the wind vane with, for example with a piece of adhesive tape. After alignment the adhesive tape has to be removed.

When you have fixed the wind vane you can locate the reference point by aiming at it over the axis. Now you must turn the sensor casing on the mounting tube until the tip of the wind vane points to the reference point in the north. To set up the sensor's north orientation select a landmark which is as far as possible up north with regard to the final position of the wind direction sensor.

The reference point can be selected using a topographical map (1:25000). The exact position of the reference point is determined using an amplitude compass that can be adjusted horizontally on a stand.



The compass declination has to be considered!

To align the sensor in a forward direction (on ships) locate a point outside the ship in the landscape which is located in the ship's forward direction respectively in the centre line or, in the case that the sensor is mounted far away from the middle line, a line parallel to the centre line. The sensor can be fastened by means of the two hexagonal screws when the tip of the wind vane points to the northern reference point. Finally the earth screw has to be connected to the ship's ground. Acid-free contact grease is recommended to protect contact surfaces against corrosion. A functional check at three points offset by 90° directions is recommended.



Follow all relevant safety instructions when mounting a sensor on a mast.

4.8.2 Power supply and signal cable

If the sensor is mounted in the correct manner and connected with the right cable (accessory), you can attach the wires for the power supply and signal outputs to the data acquisition equipment (computer). The ARCO sensor requires a 5 pole M12 plug connector. The cable shield should be connected with both ends at the ground wire (PE).



To reduce the risk of inductive interference the sensor must be properly grounded (screening on both sides).

The external connection is carried out via a central connector which is located in the housing base. For further details about the electrical connection please see section "Electrical connections".

The typical power supply requirements of the sensor are 24 VDC with a current consumption of 20 mA. The input range is 6.5...32 VDC. The heater of the ARCO is supplied with 24 VDC and has a current consumption of less than 0.9 A at heating power of 2.9 W. Under most climatological conditions the heating prevents blocking of the moving sensor parts. Neither the cup rotor nor the wind vane are heated. In the case of icing or formation of ice on the moving sensor element the function is restricted for the period of icing.

The output signal of the sensor conforms to the RS485 standard in talker mode. The line drivers are capable of transmitting data over cable lengths up to 1,220 meters (4,000 feet). The cable lengths are dependent on the quality of the cable used. As soon as the power supply of the sensor is switched on, the sensor automatically sends cyclic data.

4.8.3 Safety regulations



Because the wind sensor is often mounted in exposed locations at dangerous heights the installation personnel have to pay attention to the relevant safety regulations. During the electrical installation work the external circuitbreaker must be switched off. It is not permitted for unauthorized persons to open the housing!

5 Maintenance

5.1 Regular maintenance and calibrations

The wind sensors require very little maintenance and are designed for a long service life. Regular visual checks are recommended, regarding dirt build-up on the surface caused by the weather. Whenever this is the case, we strongly recommend to clean it. A regular visual and functional check of the wind sensor is recommended.



If reference measurements are necessary, it must be stringently noted that a comparison of the measured values is given only if the measurements take place under same conditions. I.e. the reference equipment must be used very close to the sensor!

The sensor is a measuring instrument and thus user specific standards apply regarding the period of recalibration. Manufacturer's recommendation: 2 years.

For the long-term assurance of the function and accuracy of the proposed components, we are pleased to offer you our professional maintenance and calibration services.



5.2 Visual inspections and cleaning work

The use of the sensor under the respective environmental conditions requires certain actions. It is thus recommendable to clean the outside of the housing and shelter within specific intervals. The intervals are dependant on the environmental conditions and the degree of soiling. We recommend a regular visual and functional check.

In case you should be faced with any specific problems, which you are unable to solve, please contact the LAMBRECHT meteo service:

Tel: +49 551 4958-0

E-Mail: support@lambrecht.net

6 Transports

In case it is necessary for you to ship or transport the sensor, it must be carefully packed to prevent damages during transport.

7 Data protocols

DATA PROTOCOL WIMWV

WIND DIRECTION AND WIND SPEED

Example of a data sequence with comma seperatd fields:

\$WIMWV,357.0,R,5.2,M,A*CS<CR><LF>

Field delimiter: , (comma)

Header: \$WIMWV

Wind direction (WD): 0.0 to 360.0

R: relative wind direction

Wind speed (WS): 0.3 to 75.0

M: metric unit in m/s

Status A (valid) / V (invalid)

Stop delimiters: <CR> <LF>

Error code: WR 999.9

Error code: WG 99.9

NOTE:

In the development of a NMEA decoder fixed field lengths should not be assumed. The NMEA definition is based on a variable field length. The comma character (',') serves as a field separator. Numerical values in a field can be represented in different ways.

If a field is not sent, it has a length of 0 characters (,).

The check sum „CS“ is output as a 2 character hexadecimal value. All characters in the data sequence between „\$“ and „*“, but excluding „\$“ and „*“ are calculated as XOR function.

<CR>...carriage return (hexOD),

<LF>...linefeed (hex 0A)

Further protocols available on request.

8 Dimensional drawings ARCO-SERIAL and ARCO-NAV

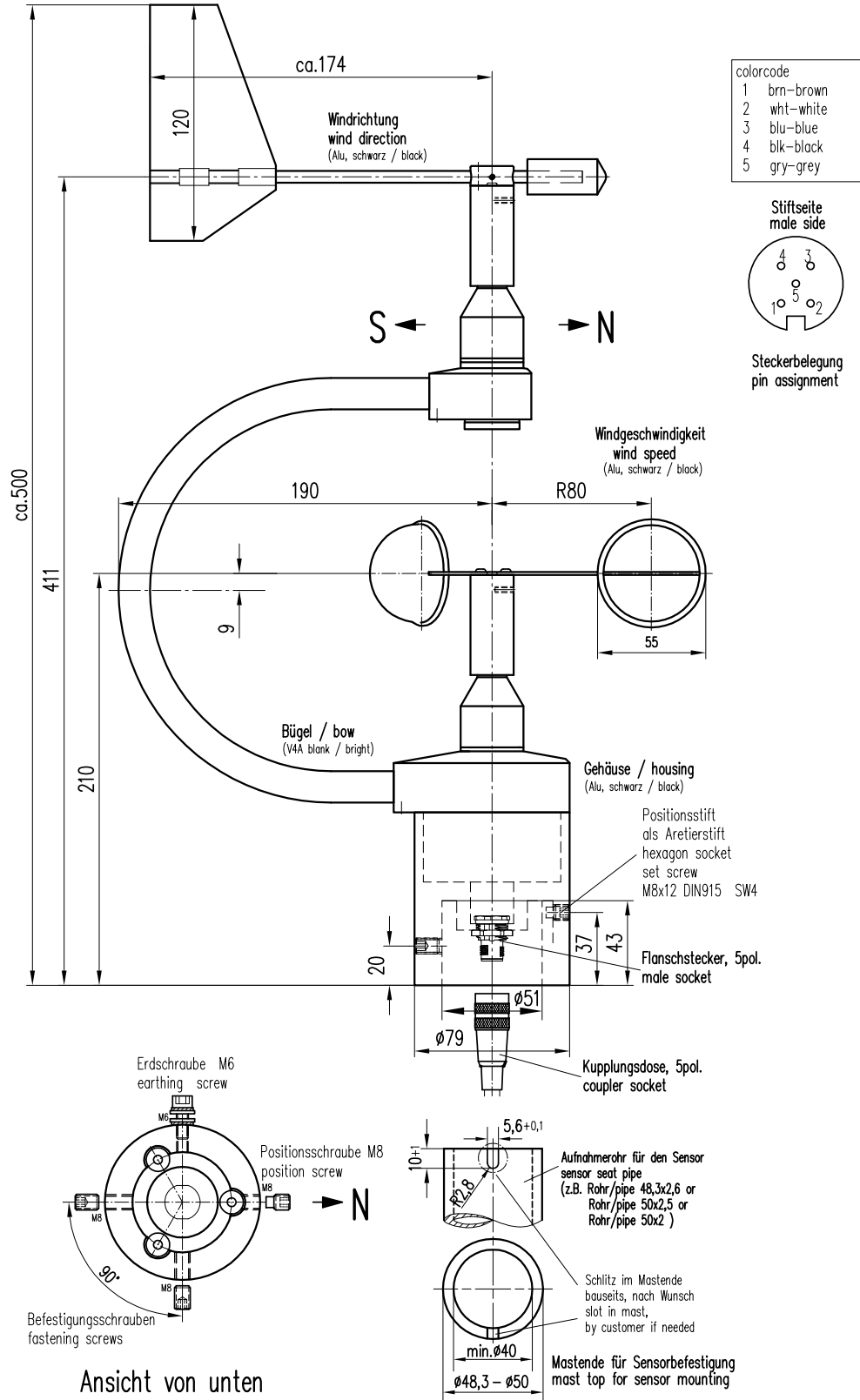

9 Electrical connections ARCO-SERIAL and ARCO-NAV

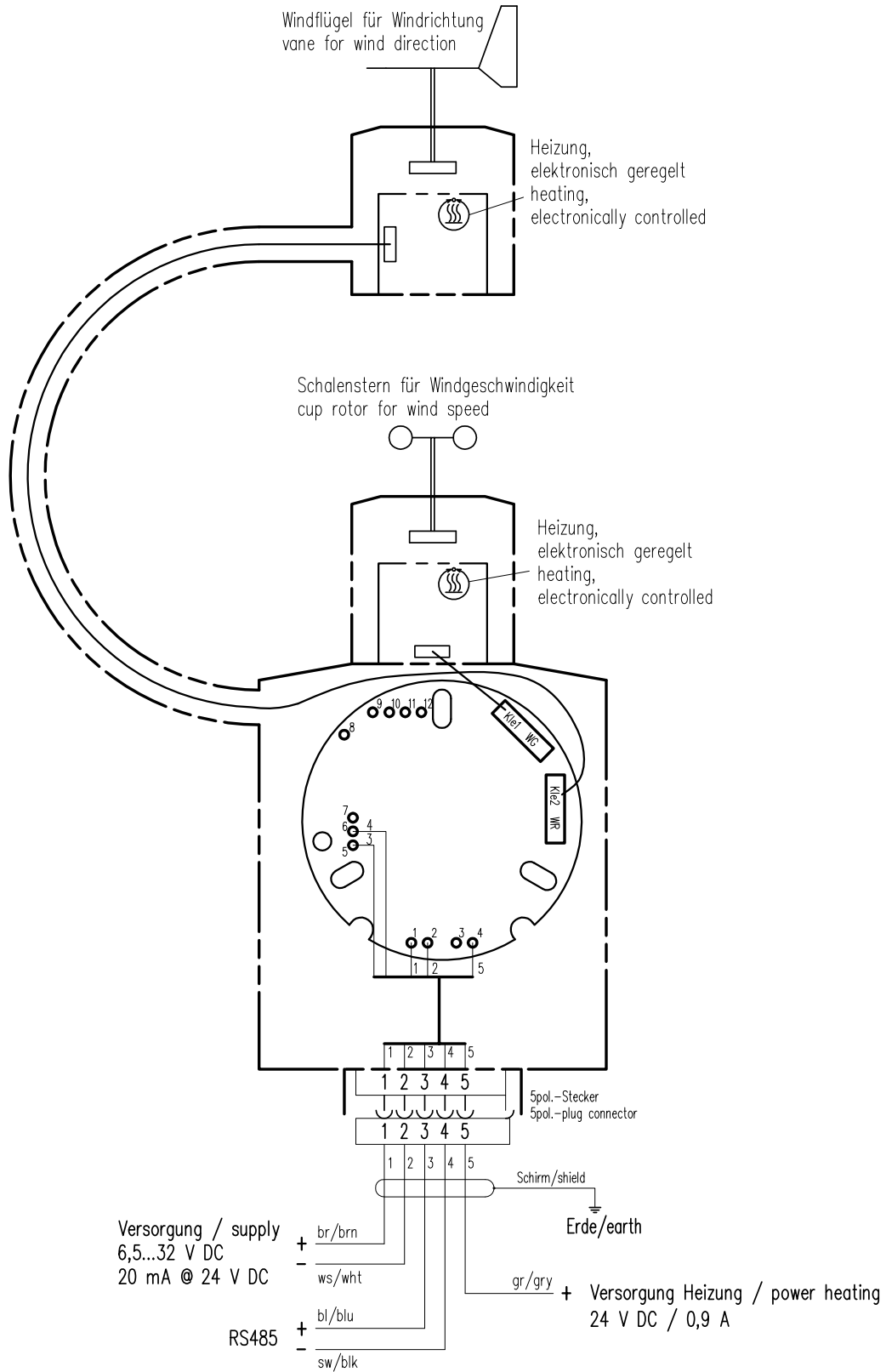

10 Technical data

ARCO-SERIAL AND ARCO-NAV	
ID	00.14581.010010 ARCO-SERIAL 00.14581.110010 ARCO-NAV
Range of application	Temperature: -40...+70 °C heated * Wind speed: 0...80 m/s Relative humidity: 0...100 % r. h.
Supply voltage	Sensor: 6.5...32 VDC/20 mA at 24 VDC Heating electronically controlled 24 VDC/2.9 W
Interface	serial RS 485/Talker Baud rate 4800; 1 Hz (at measuring cycle 10 Hz); 8 N1
Protocols	NMEA 0183; WIMWV
Standards	EMC/EMI: EN 60945; Low voltage guideline 73/23/EWG and VDE 0100; WMO No. 8; VDI 3786 part 2; NMEA 0183
Housing	seawater resistant aluminum specially coated and RAL 9003 protective coating (ARCO-NAV); IP 65 in vertical position of use
Dimensions	see dimensional drawings
Weight	approx. 1.7 kg
Parameter Wind Direction	
Measuring range	0...360°
Accuracy	±1%
Resolution	<1°
Starting value	0.3 m/s
Damping ratio	0.5...0.6
Parameter Wind Speed	
Measuring range	0.3...75 m/s
Accuracy	±2% FS at 0.3...60 m/s
Resolution	<0.1 m/s
Starting value	0.3 m/s
Distance constant	4 m
Accessories (please order separately)	
ID 32.14581.060000	Sensor cable, 10 m, 5 pole M12 plug
Option (please order separately)	
ID 36.09340.000000	Visualization and evaluation software: MeteoWare-CS-3 Basic

*) Remark: In the case of icing and formation of ice at the moveable sensor measuring element, the function is restricted for the period of icing.